

**OPERATION**

This valve allows free flow from 1 to 2 and blocks flow from 2 to 1.

**SPECIFICATIONS**

Theoretical performance

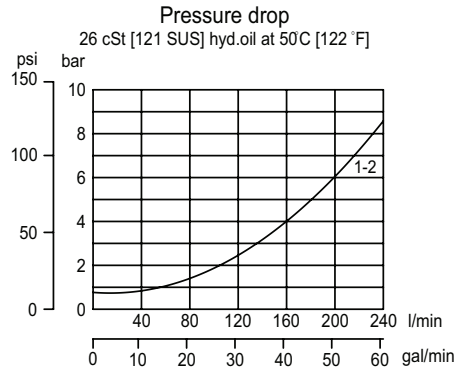

Schematic



Specifications

Rated pressure*	315 bar [4570 psi]
Rated flow at 7 bar [100 psi]	210 l/min [55.5 US gal/min]
Leakage	6 drops/min @ Rated pressure
Weight	0.26 kg [0.57 lb]
Cavity	SDC16-2

\*Rated pressure based on NFPA fatigue test standard (at 1 million cycles)

**DIMENSIONS**

mm in

Cross-sectional view

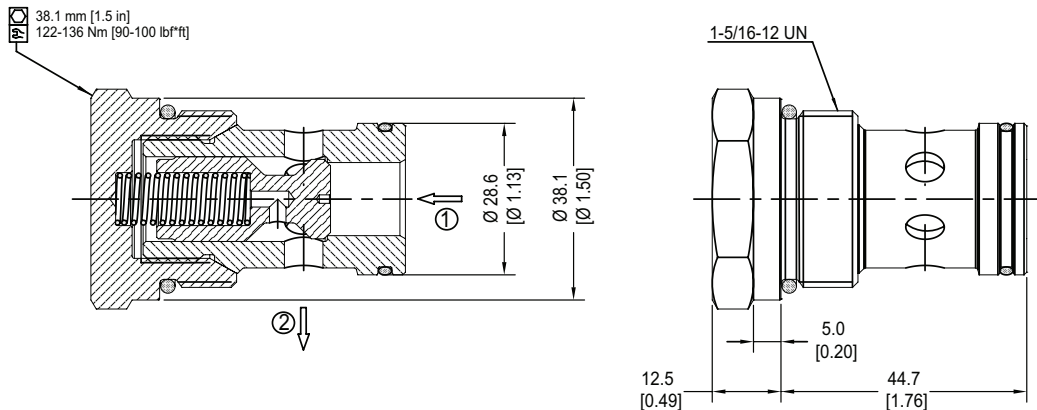

**ORDERING INFORMATION**

**CP102-1-B-0-005**

Check Valve  
Poppet Type, Normal Direction

Seal Kit	Seal Option
120019	B = Buna-N
120020	V = Viton

Code	Ports & Material	Body Nomenclature
0	0 = Cartridge only	No Body
DG6B	Al, 3/4 BSP	SDC16-2-DG-6B
DG8B	Al, 1 BSP	SDC16-2-DG-8B
12S	Al, #12 SAE	CP16-2-12S
16S	Al, #16 SAE	CP16-2-16S

Crack Pressure	
005	0.34 bar [5 psi]
015	1.0 bar [15 psi]
030	2.1 bar [30.4 psi]
040	2.8 bar [40 psi]
065	4.5 bar [65 psi]
100	6.9 bar [100 psi]

\*\*Aluminum bodies are to be used for pressures less than 210 bar (3000 psi)  
 \*\*\* Other housings available