

# Injection oilers, micro pumps

## for minimal quantity metering

Injection oiler, 3-port type

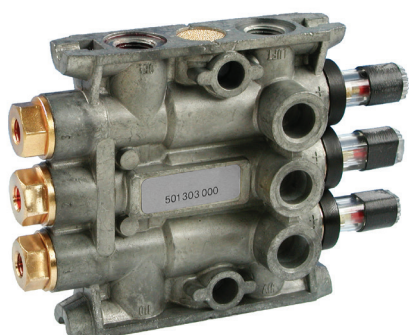

Injection oiler, 1-port type

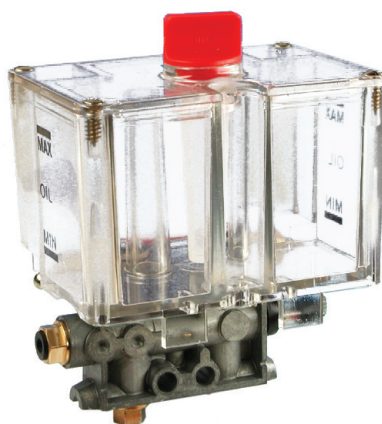

Micro pump



### Delivery rates

Metering pumps deliver lubricants in a measured amount. These piston pumps are for small delivery rates from 3 to 30 mm<sup>3</sup>. The lubricant's delivery rate is partially adjustable.

### Main features

- Optimal metering of every lube point regardless of line lengths and cross sections
- Lubricant supplied from one central reservoir, a standalone reservoir, and also by a central pressurized oil line in the case of injection oilers
- Metering elements can be actuated individually or in groups
- Splash lubrication through high oil acceleration (injection oiler)
- Fast sequence of pulses: up to 120 pulses per minute (injection oiler)
- Space saving design
- Ecofriendly: no oil in the exhaust air

### Possible applications

- Air oiling (assembly tools)
- Greasing of small parts (assembly support)
- Chain lubrication

Oiling during production of camshafts

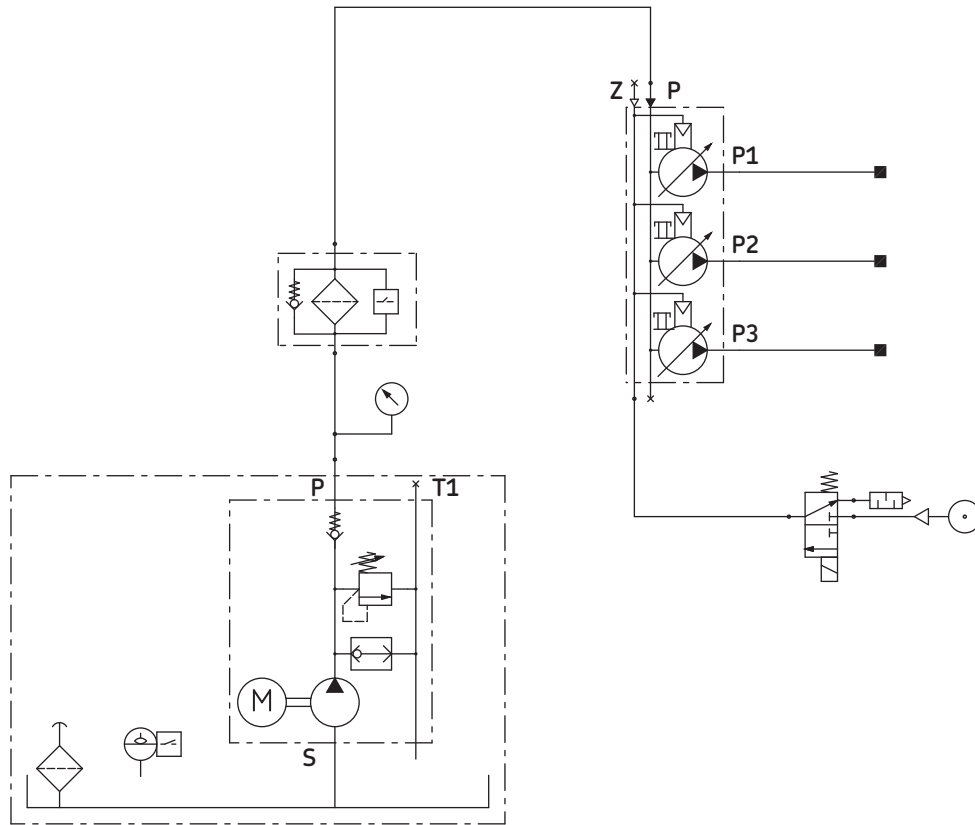

Adjustment of delivery rate

All injection oilers are set for maximum delivery volume at the plant. The delivery rate can be reduced in increments by turning the setting sleeve counterclockwise.

Max. delivery rate/stroke	30 mm <sup>3</sup>
1 full turn to the left:	25 mm <sup>3</sup>
2 full turns to the left:	20 mm <sup>3</sup>
3 full turns to the left:	15 mm <sup>3</sup>
4 full turns to the left:	10 mm <sup>3</sup>
5 full turns to the left:	5 mm <sup>3</sup>
over 6 full turns to the left:	3 mm <sup>3</sup>

The setting sleeve can be set by hand. It engages 4 times per revolution (which can be heard and felt) so that intermediate settings are also possible. The maximum delivery rate is set again by turning the setting sleeve clockwise to the stop.

The first start-up should take place at the maximum delivery rate.

Sectional view of injection oiler

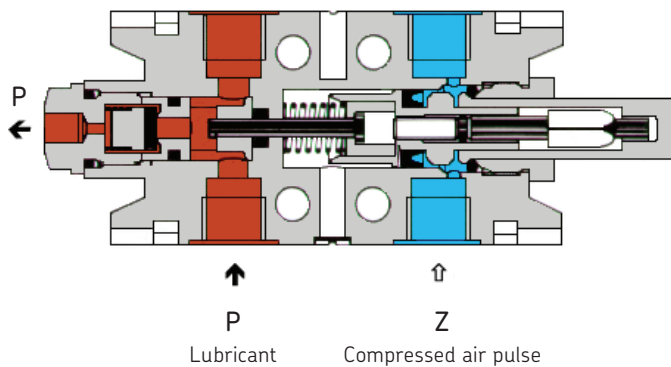

# Injection oiler, 1- and 3-port type

See important product usage information on the back cover.

**Technical data**

Ambient temperature -20 to +80 °C  
 Lubricant . . . . . oil <sup>1)</sup>  
 Operating viscosity . . . 10 to 1100 mm<sup>2</sup>/s  
 Pumping medium:  
 Compressed air (Z) . . . 3 to 10 bar  
 Max. perm. flow rate at 6 bar . . . 200 l/min  
 Mounting position. . . oil duct **S** vertical

1) other media on request.  
 If fluid grease or grease is used, the suction action must be supported with priming (max. 3 bar). Please inquire about the correct use of other media.

**Setting sleeves**

- a** Setting sleeve for adjustment of quantity and manual actuation for additional triggering of a lube pulse
- b** Indicator pin for function display
- c** Guard cap

**S** = oil feed  
**P** = oil outlet port  
**Z** = compressed air

**Attention: direction of rotation**

- turn to the left
- + turn to the right

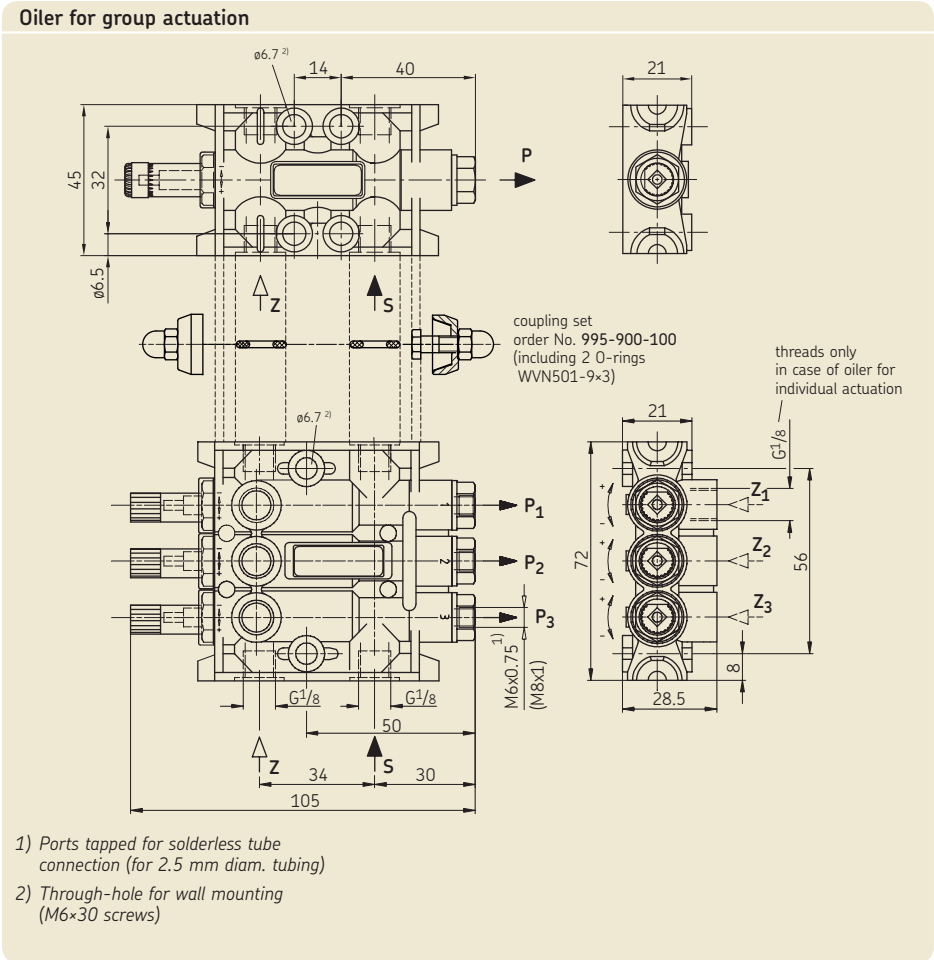

Version	Delivery rate [cm <sup>3</sup> /stroke]	Order No.	for tube diam.	Lateral connections for sensor Z S	Seal material	Features, application
1-port type	0.003 – 0.03	501-301-000	2.5	no	NBR	Individual use, can be coupled to further 1- and 3-port-injection oilers. Basis unit for injection oiler with reservoir.
		501-301-008	2.5	no	FPM	
		501-301-024	4	no	NBR	
		501-301-024-VS	4, quick connector	no	NBR	Basis unit for injection oiler with reservoir and sensor (combined oiler)
		501-301-025	4	no	FPM	
		501-301-053	4, quick connector	no	NBR	
		501-301-001	2.5	yes	NBR	
501-301-002	2.5	yes *)	NBR	external oil discharge		
3-port type	0.003 – 0.03	501-303-000	2.5	no	NBR	group actuation
		501-303-008	2.5	no	FPM	group actuation
		501-303-003	2.5	no	NBR	individual actuation
		501-303-024	4	no	NBR	group actuation
		501-303-028	4	no	FPM	group actuation
		501-303-029	4	no	FPM	individual actuation
		501-303-026-VS	4, quick connector	no	NBR	group actuation
3-port type	0.003 – 0.03	501-303-037	4	no	NBR	individual actuation, piston monitoring
		501-303-038	4	no	NBR	group actuation, piston monitoring

\*) yes, but internal oil path covered by gasket 818-100-007

# Injection oiler, 1-port or 3-port type, with proximity switch

Injection oiler with proximity switch, order No. 501-301-095

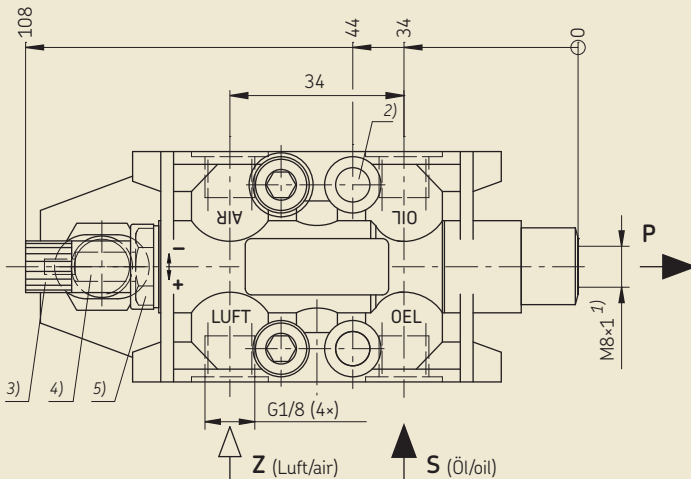

- 1) Ports tapped for solderless tube connection (for 4 mm diam. tubing)
- 2) Through-hole for wall mounting (screws DIN 912 - M6)
- 3) Setting sleeve for adjustment of delivery rate and manual action for additional triggering of a lubrication pulse
- 4) Optical indicator pin
- 5) Guard cap

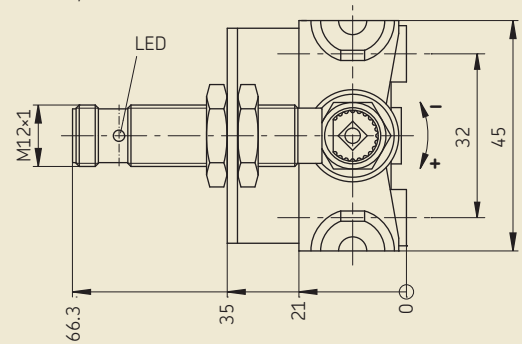

Injection oiler with proximity switch, order No. 501-303-037 and 501-303-038

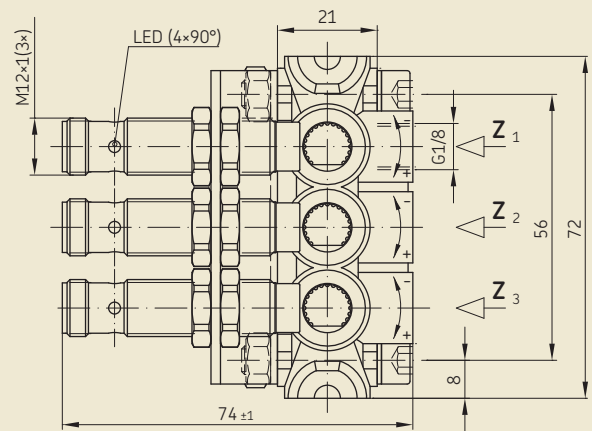
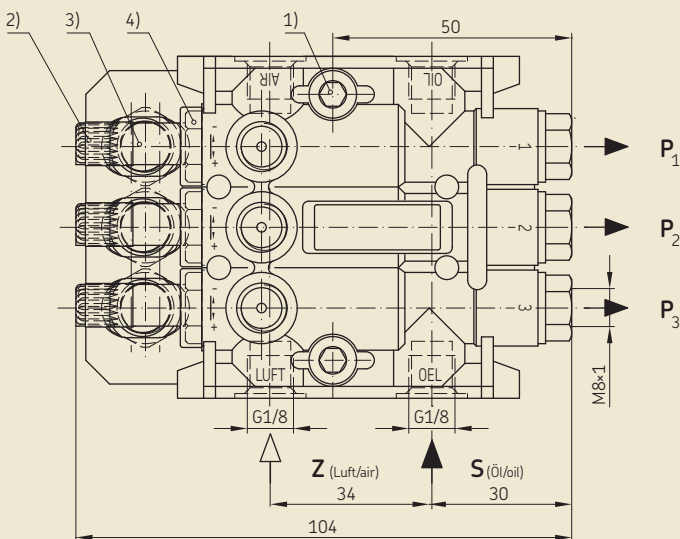

- 1) Through-hole (ø6.7) for wall mounting (Schrauben DIN 912 - M6)
- 2) Setting sleeve for adjustment of delivery rate and manual action for additional triggering of a lubrication pulse
- 3) Optical indicator pin
- 4) Guard cap

### Circuit diagram

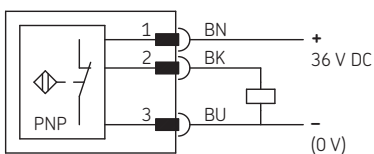

### Technical data

Ambient temperature . . . . . -20 to +80 °C  
 Lubricant . . . . . oil <sup>1)</sup>  
 Operating viscosity . . . . . 10 to 1100 mm<sup>2</sup>/s  
 Actuation medium:  
 Compressed air (Z) . . . . . 3 to 10 bars  
 Max. perm. flow rate at 6 bars . . 200 l/min  
 Seal material . . . . . NBR  
 Mounting position . . . . . oil duct S vertical

### Proximity switch

Rated voltage . . . . . 24 V DC  
 Operating voltage . . . . . 36 V DC  
 Rated current . . . . . 100 mA  
 Switching indicator . . . . . LED

<sup>1)</sup> other media on request. If fluid grease or grease is used, the suction action must be supported with priming (max. 3 bar). Please inquire.

# Injection Oilers, Micro Pumps

**Injection oiler, 1-port type**

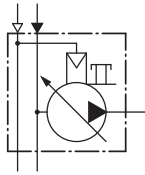

**Injection oiler, 3-port type, individual actuation**

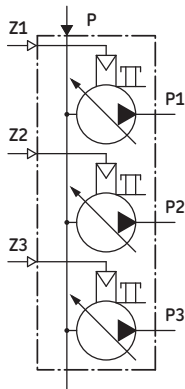

**Injection oiler, 3-port type, group actuation**

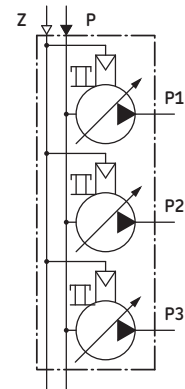

**Air flow with individual actuation**

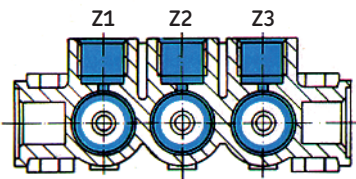

**Air flow with group actuation**

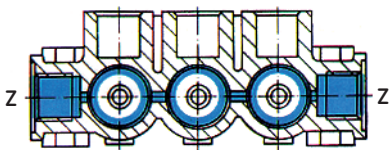

**Example 1: Gravity oil layout (group actuation)**

S = oil feed  
P = oil outlet port  
Z = compressed air port

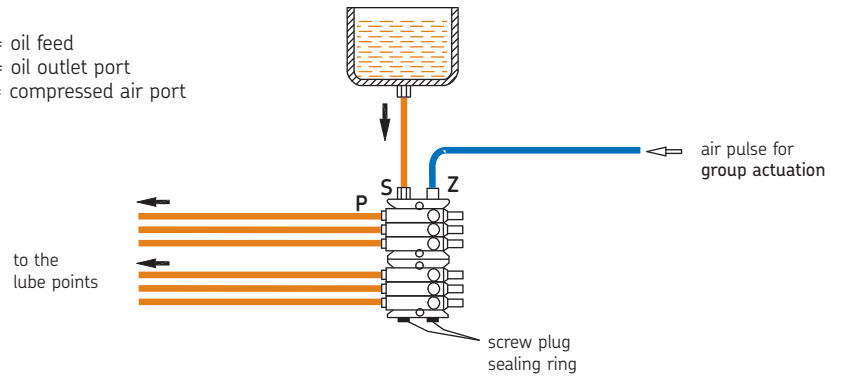

**Example 2: Gravity oil layout with venting line (group and individual actuation combined)**

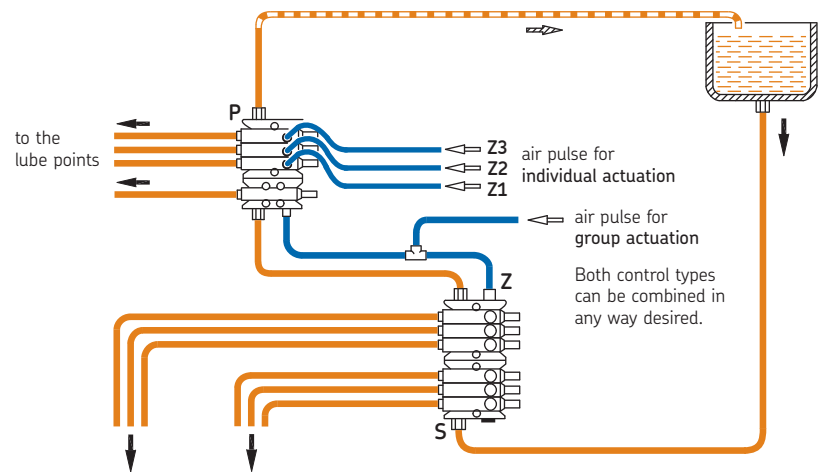

**Example 3: Configuration of a large system with ring line (group actuation)**

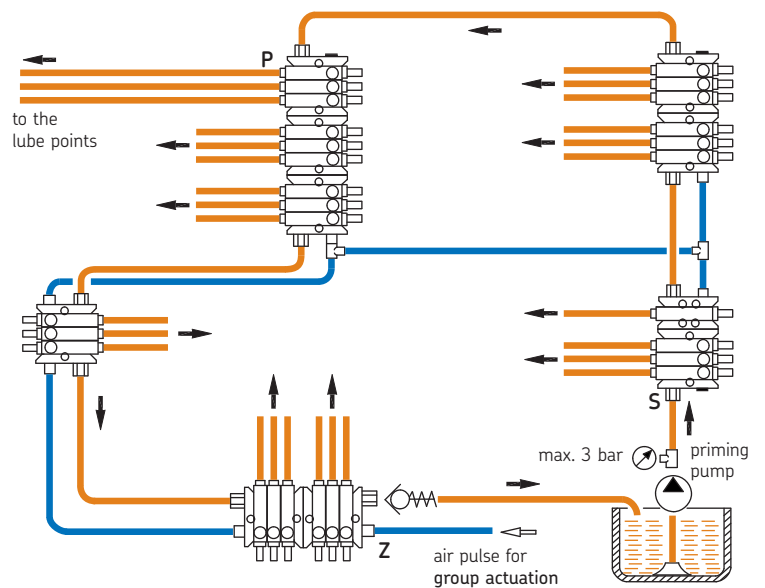



## Injection oiler, 1-port type, with reservoir

The reservoir is equipped with a float switch (WS) for minimum level.

The float switch opens with sinking level.  
 Circular plug connection M12×1  
 Max. load: 10 VA  
 0.25 A  
 240 V AC

**P** = oil outlet  
**Z** = compressed air connection

Order No.	Reservoir capacity [l]	Seal material
501-301-056	0.8	NBR

Mounting position as shown  
 See page 3 for technical data  
 See page 2 for adjustment of delivery rate

Injection oiler with reservoir, order No. 501-301-056

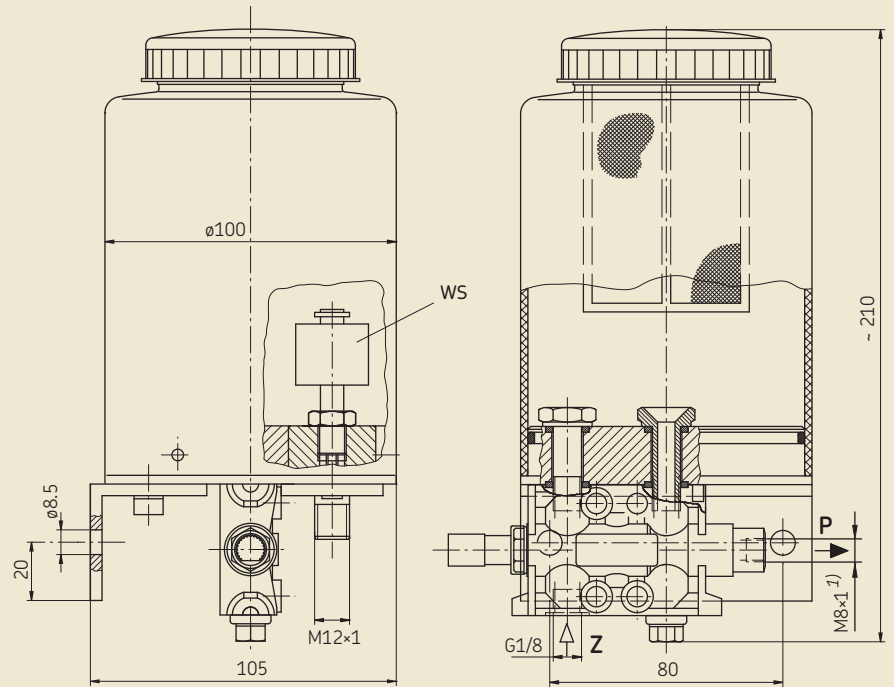

1) Ports tapped for solderless tube connection (for 4 mm diam. tubing)





# Grease reservoir

### Technical data

Order No. . . . . . BF1.5

Compressed air  
for following piston . . . max. 10 bar

Lubricant . . . . . grease up to  
NLGI grade 2

Reservoir capacity . . . 1.5 kg

Mounting position. . . any

### Connection fittings

for M14x1.5:  
socket union 408-202  
double tapered sleeve 408-001

for G<sup>1</sup>/<sub>4</sub>:  
washer 508-108  
adaptor 406-054 for tube 6 mm diam.  
or 301-020 for tube 8 mm diam.

### Grease reservoir, order No. BF1.5

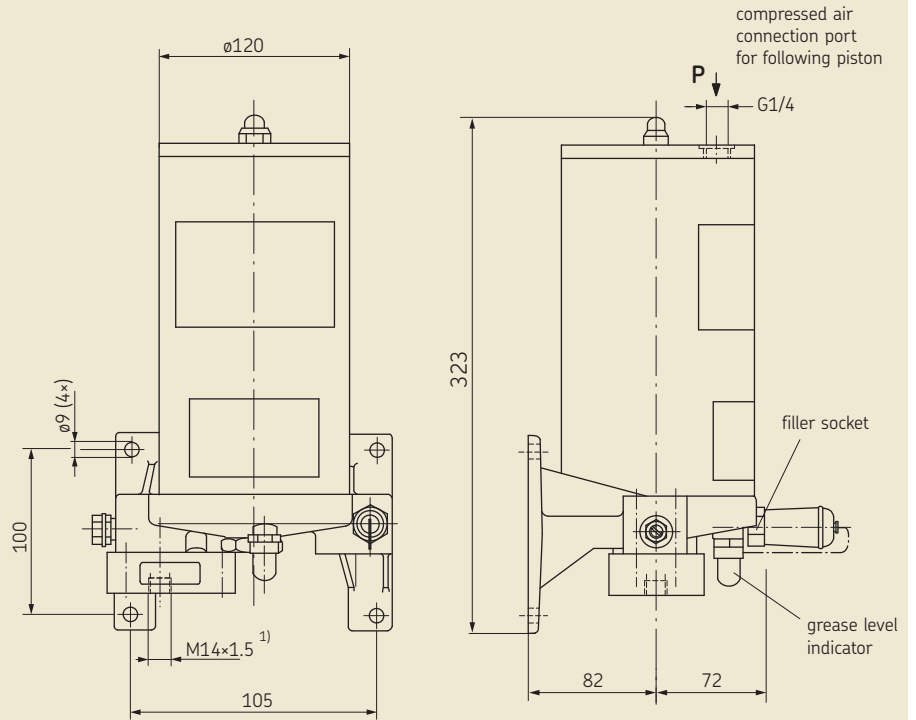

1) Ports tapped for solderless tube connection (for 8 mm diam. tubing)

## Micro pumps



2-port type on baseplate

The micro pump is a pneumatically actuated, miniature piston pump. The compressed air controlled by a 3/2-way valve actuates the delivery piston, which discharges the respective output on the basis of its displacement. The travel of the stroke, and thus the metering of the delivery rate, is increased or decreased with setting rings.

Care must be taken to make sure that the compressed-air line leading to the pump is relieved of pressure after each actuation so that the delivery piston can return to its initial position.

The micro pump is specially designed for minimal quantity lubrication, and, namely, only for cases in which oil is to be sprayed on with compressed air. The necessary accessories are documented in leaflet 1-5012-5-EN.

### Micro pump, baseplate

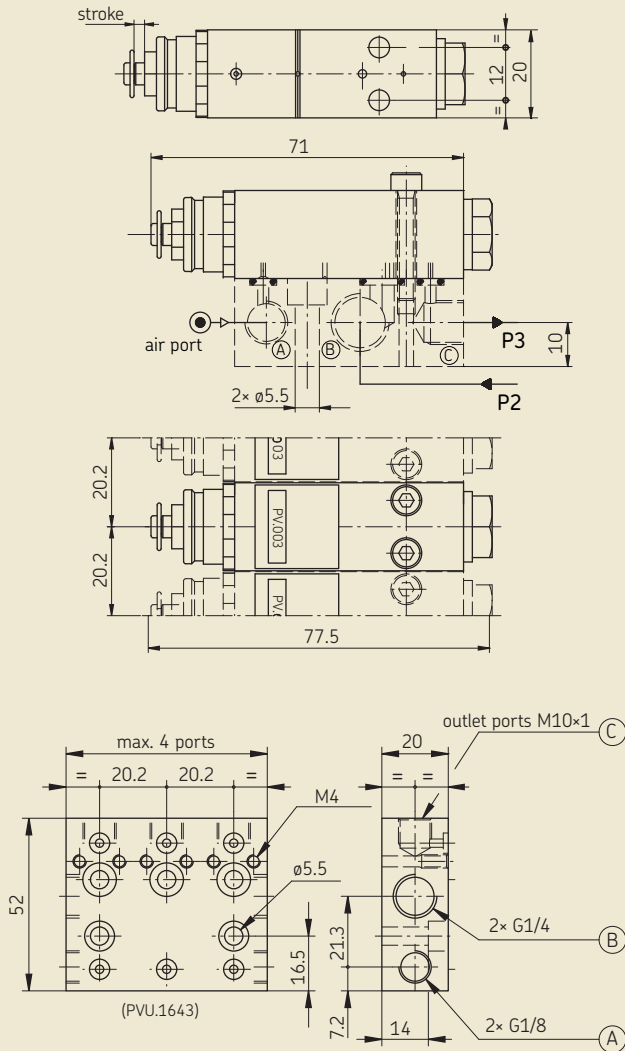

#### Micro pump

Order No.	Metering
PVR-003	metering rate adjustable from 0-30 mm <sup>3</sup>
PV-003	fixed metering rates with setting ring: 3, 5, 10 and 30 mm <sup>3</sup>

#### Baseplate

Order No.	Number of pumps
PV.1641	1
PV.1642	2
PV.1643	3
PV.1644	4
PV.1645	5

#### Technical data

Air pressure . . . . . 4-8 bar  
 Ambient temperature . . . . . -20 to +70 °C  
 Frequency . . . . . max. 3 Hz  
 Operating temperature +10 to +70 °C  
 Max. delivery pressure approx. 35 bars

Lubricant . . . . . mineral oils without additives, max. viscosity 400 mm<sup>2</sup>/s

Oil feed . . . . . gravity oil reservoir



**Order No. 1-5012-4-EN**

Subject to change without notice! (07/2014)

**Important product usage information**

All products from SKF may be used only for their intended purpose as described in this brochure and in any instructions. If operating instructions are supplied with the products, they must be read and followed.

Not all lubricants are suitable for use in centralized lubrication systems. SKF does offer an inspection service to test customer supplied lubricant to determine if it can be used in a centralized system. SKF lubrication systems or their components are not approved for use with gases, liquefied gases, pressurized gases in solution and fluids with a vapor pressure exceeding normal atmospheric pressure (1013 mbars) by more than 0.5 bar at their maximum permissible temperature.

Hazardous materials of any kind, especially the materials classified as hazardous by European Community Directive EC 67/548/EEC, Article 2, Par. 2, may only be used to fill SKF centralized lubrication systems and components and delivered and/or distributed with the same after consulting with and receiving written approval from SKF.

**Further brochures**

1-4003-EN Electromagnetic pump PE

1-9201-EN Transport of Lubricants in Centralized Lubrication Systems

**SKF Lubrication Systems Germany GmbH**

Motzener Strasse 35/37 · 12277 Berlin · Germany

PF 970444 · 12704 Berlin · Germany

Tel. +49 (0)30 72002-0 · Fax +49 (0)30 72002-111

[www.skf.com/lubrication](http://www.skf.com/lubrication)

This brochure was presented by:

® SKF is a registered trademark of the SKF Group.

© SKF Group 2014

The contents of this publication are the copyright of the publisher and may not be reproduced (even extracts) unless prior written permission is granted. Every care has been taken to ensure the accuracy of the information contained in this publication but no liability can be accepted for any loss or damage whether direct, indirect or consequential arising out of the use of the information contained herein.

