



CURTIS

A KOHLER COMPANY



Motor Controllers

ACF4-A ACF6-A ACF10-A

AC Motor Controllers with VCL

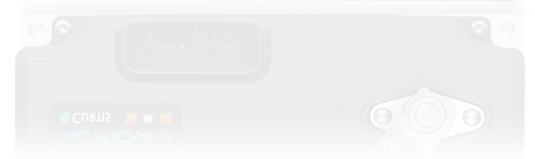
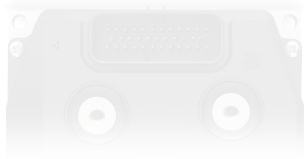



Superb Performance

The Curtis Model AC F4-A, AC F6-A and AC F10-A Motor Controllers provide accurate speed and torque control of 3-phase AC induction, PMAC and BLDC motors.

Models AC F4-A, AC F6-A and AC F10-A include dual ARM Cortex microprocessors that provide a category 2 designated architecture for functional safety, as well as efficient motor control and flexible system control. The controllers are designed for electric traction, hydraulic pump and on-engine generator (OEG) hybrid systems on mobile equipment applications such as forklift and warehouse trucks, airport ground support equipment, mobile elevating work platforms, construction equipment, golf cars and turf care machinery. These models are also powerful system controllers that can operate as commander devices on the CANbus.

Models AC F4-A, AC F6-A and AC F10-A share the same features and I/Os. The major differences are the current ratings: Model AC F10-A has the highest current ratings and Model AC F4-A has the lowest. Model AC F10-A also includes a fuse terminal that eliminates the need for a vehicle-based or harness-based fuse holder.

All models include the following features.

FEATURES

Fit for Purpose

- ▶ Field-oriented motor control algorithms maintain optimal performance for 3-phase AC motors under all operating conditions.
- ▶ Real-time motor torque and power estimates optimize vehicle-level power.
- ▶ Rugged housing with a small footprint for the power rating.
- ▶ Heavy-duty busbars for motor and battery connectors.
- ▶ Sealed, 35-pin AMPseal I/O connector.
- ▶ Impervious to most oils, solvents, degreasers and other chemicals often encountered by industrial vehicles.
- ▶ IP67 environmental protection as per IEC 60529.
- ▶ Exceeds global conformance requirements for functional safety, electrical safety and EMC.
- ▶ CE/UKCA marked as a programmable safety device.
- ▶ UL583 recognized component.

Motors

- ▶ Works with any AC induction, PMAC or BLDC motor.
- ▶ Motor auto-characterization simplifies on-truck pairing with different induction motor types.
- ▶ Comprehensive library of induction and PMAC motor types stored in controller memory.

You Feel It When You Drive It— Maximum Torque, Minimum Losses, Full Control

- ▶ Curtis' renowned field-oriented control algorithms and PWM switching technology assure maximum torque and system efficiency across the entire torque/speed spectrum.
- ▶ Smooth and predictable drive control that only Curtis can deliver.





FEATURES continued

Get More Out of Your Battery— Regardless of the Technology

- ▶ High-efficiency means more of your battery’s energy is converted to motor output power.
- ▶ Configurable overvoltage and undervoltage protection parameters.
- ▶ Wide operating voltage range allows use with cell chemistries such as lithium ion.
- ▶ Configurable CANbus and VCL allow easy integration with the Battery Management Systems (BMS) typically found on lithium battery packs.

Powerful Dual Microprocessors

- ▶ Dual-micro architecture achieves up to PL=d, category 2 functional safety under EN ISO 13849-1:2015 and EN 1175:2020.
- ▶ Blazing processor speeds for precise regulation of voltage, frequency and current.

Customize Your Vehicle with VCL

- ▶ The Curtis Vehicle Control Language (VCL) enables Curtis AC Motor Controllers to operate as system controllers, eliminating the need for costly additional controllers.

Inertial Measurement Unit (IMU)

- ▶ Six-axis IMU for measurement of orientation, movement and impact detection (optional).



Flexible I/O

- ▶ All I/O pins are multi-function, and can be configured to provide up to:
 - Twenty-seven digital inputs
 - Nine analog inputs
 - Two potentiometer sources
 - Seven output drivers

Comprehensive CAN Capabilities

- ▶ Configurable 11 or 29 bit protocol support for CANopen or J1939 use.
- ▶ Dual independent CAN ports. A full galvanic isolation option is available.
- ▶ Plug and play support for Curtis CAN displays and CAN tiller heads from leading manufacturers FREI and REMA.
- ▶ Fully CANopen compliant per CiA 301.
- ▶ Acts as a “CAN interpreter” that allows third-party CAN devices with differing profiles to work on the same CANbus.

Diagnostics

- ▶ Status LED for at-a-glance system troubleshooting.
- ▶ Thermal cutback, warning and automatic shutdown protect the motor and controller.
- ▶ Error logging, fault history and CAN Emergency Messages.

CAN-based Programming

- ▶ Programmable over the CANbus.
- ▶ Supports most CAN-based service tools used by major industrial truck manufacturers worldwide.
- ▶ Develop, configure, optimize and debug vehicle systems with the Curtis Integrated Toolkit.





SYSTEM ACCESSORIES



Curtis Model 3150

A CAN-based color LCD vehicle status display in a rugged 52 mm diameter housing.

- ▶ Battery Discharge Indicator, Service (Hours) Counter and Diagnostic/Message Center functions.
- ▶ Sealed to IP67 front and IP65 rear.
- ▶ CE/UKCA compliant.
- ▶ UL583 recognized component.
- ▶ Optional heater.
- ▶ For more information, see the [Curtis Instrumentation page](#).

The Curtis Integrated Toolkit

The Curtis Integrated Toolkit (CIT) provides a suite of development and diagnostic tools for working with CAN systems that use Curtis and third-party CAN devices. CIT consists of the following tools:

- | | |
|--|---|
| <ul style="list-style-type: none"> ▶ Launchpad
Starting point and project editor. ▶ Programmer
Configure parameters, view monitor values, and view active faults and the fault history. ▶ TACT
Stand-alone oscilloscope and data-logging tool. | <ul style="list-style-type: none"> ▶ VCL Studio
Editor and compiler for VCL software. ▶ Menu Editor
Create and modify programming menus. ▶ Package & Flash
Load your software into CAN devices. |
|--|---|

The Curtis Integrated Toolkit is compatible with many leading USB>CAN interface dongles from Peak, Kvaser, iFAC, Sontheim, etc. For more information, see the [Curtis Programming page](#).





MODEL CHART

Model	Nominal Battery Voltage	Maximum Current: [S2-2 minutes]*	Typical Current: [S2-60 minutes]*	IMU	Isolated CAN
AC F4-A 24-375-001	24V	375 Arms	290 Arms	No	No
AC F4-A 24-375-101	24V	375 Arms	290 Arms	Yes	Yes
AC F4-A 36-500-001	24-36V	500 Arms	245 Arms	No	No
AC F4-A 36-500-101	24-36V	500 Arms	245 Arms	Yes	Yes
AC F4-A 48-350-001	36-48V	350 Arms	205 Arms	No	No
AC F4-A 48-350-101	36-48V	350 Arms	205 Arms	Yes	Yes
AC F4-A 48-375-001	36-48V	375 Arms	210 Arms	No	No
AC F4-A 48-375-101	36-48V	375 Arms	210 Arms	Yes	Yes
AC F4-A 48-450-001	36-48V	450 Arms	210 Arms	No	No
AC F4-A 48-450-101	36-48V	450 Arms	210 Arms	Yes	Yes
AC F4-A 80-300-101	48-80V	300 Arms	140 Arms	Yes	Yes
AC F4-A 96-150-201	72-96V	150 Arms	140 Arms	No	Yes
AC F4-A 96-300-101	72-96V	300 Arms	135 Arms	Yes	Yes
AC F6-A 36-650-001	24-36V	650 Arms	295 Arms	No	No
AC F6-A 36-650-101	24-36V	650 Arms	295 Arms	Yes	Yes
AC F6-A 48-650-001	36-48V	650 Arms	265 Arms	No	No
AC F6-A 48-650-101	36-48V	650 Arms	265 Arms	Yes	Yes
AC F6-A 80-375-101	48-80V	375 Arms	180 Arms	Yes	Yes
AC F6-A 80-450-101	48-80V	450 Arms	205 Arms	Yes	Yes
AC F6-A 96-450-101	72-96V	450 Arms	195 Arms	Yes	Yes
AC F10-A 36-650-001	24-36V	650 Arms	370 Arms**	No	No
AC F10-A 36-650-101	24-36V	650 Arms	370 Arms**	Yes	Yes
AC F10-A 36-800-001	24-36V	800 Arms	440 Arms**	No	No
AC F10-A 36-800-101	24-36V	800 Arms	390 Arms**	Yes	Yes
AC F10-A 36-1000-001	24-36V	1000 Arms	440 Arms**	No	No
AC F10-A 36-1000-101	24-36V	1000 Arms	440 Arms**	Yes	Yes
AC F10-A 60-650-001	36-60V	650 Arms	370 Arms**	No	No
AC F10-A 60-650-101	36-60V	650 Arms	370 Arms**	Yes	Yes
AC F10-A 60-800-001	36-60V	800 Arms	390 Arms**	No	No
AC F10-A 60-800-101	36-60V	800 Arms	390 Arms**	Yes	Yes
AC F10-A 60-1000-001	36-60V	1000 Arms	440 Arms	No	No
AC F10-A 60-1000-101	36-60V	1000 Arms	440 Arms	Yes	Yes
AC F10-A 80-550-101	60-80V	550 Arms	260 Arms**	Yes	Yes
AC F10-A 80-650-101	60-80V	650 Arms	280 Arms**	Yes	Yes
AC F10-A 80-750-101	60-80V	750 Arms	325 Arms	Yes	Yes
AC F10-A 96-650-101	72-96V	650 Arms	325 Arms	Yes	Yes

* The S2-2 minute and S2-60 minute ratings are the currents typically reached before thermal cutback occurs. The ratings are based on mounting the controller to a 6 mm thick vertical steel plate with 6 km/h (1.7 m/s) airflow perpendicular to the plate and operating the controller with an ambient temperature of 25°C.

** Subject to change, please contact your Curtis sales representative for more information.



DIMENSIONS

AC F4-A

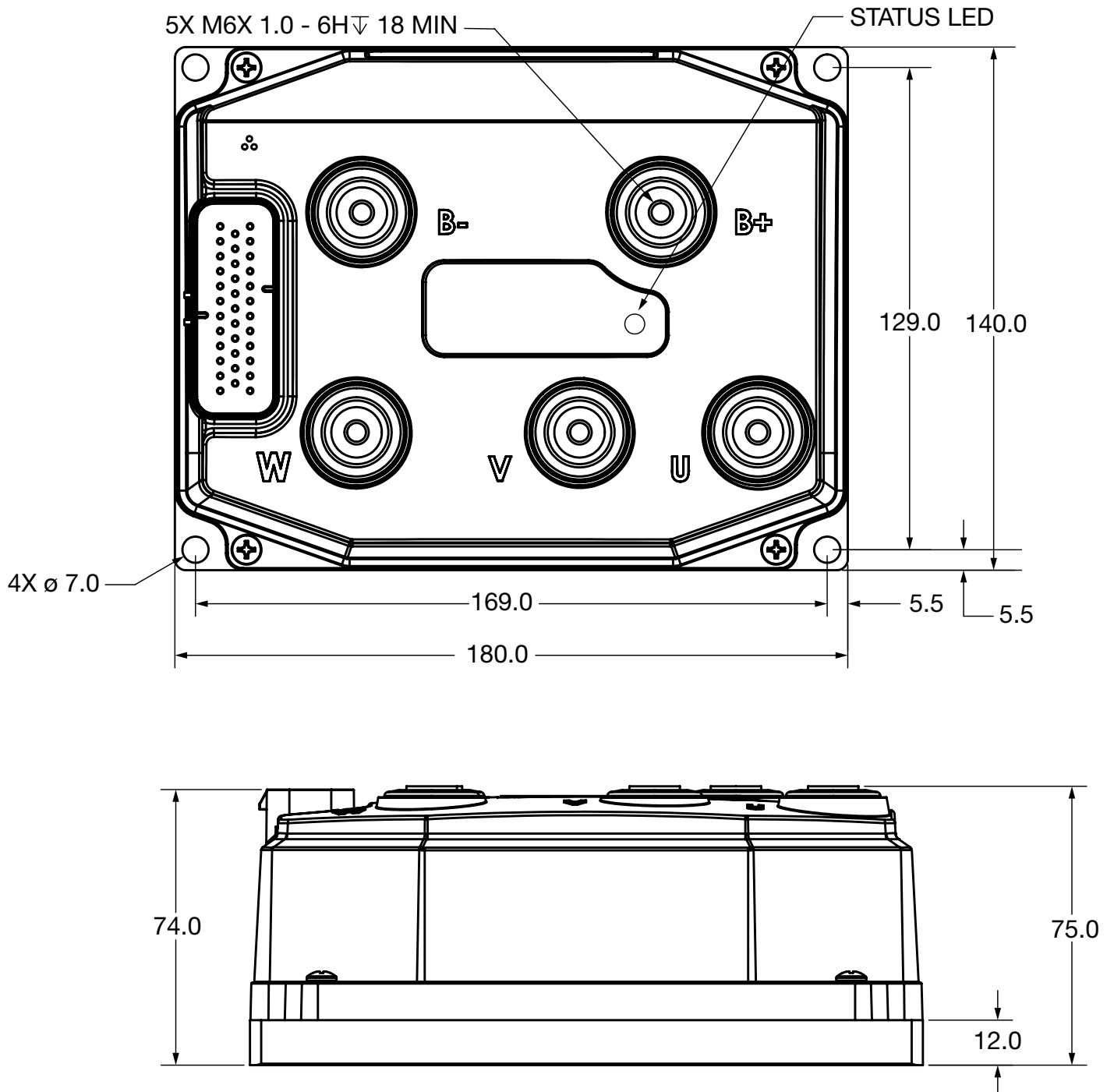



DIMENSIONS

AC F6-A

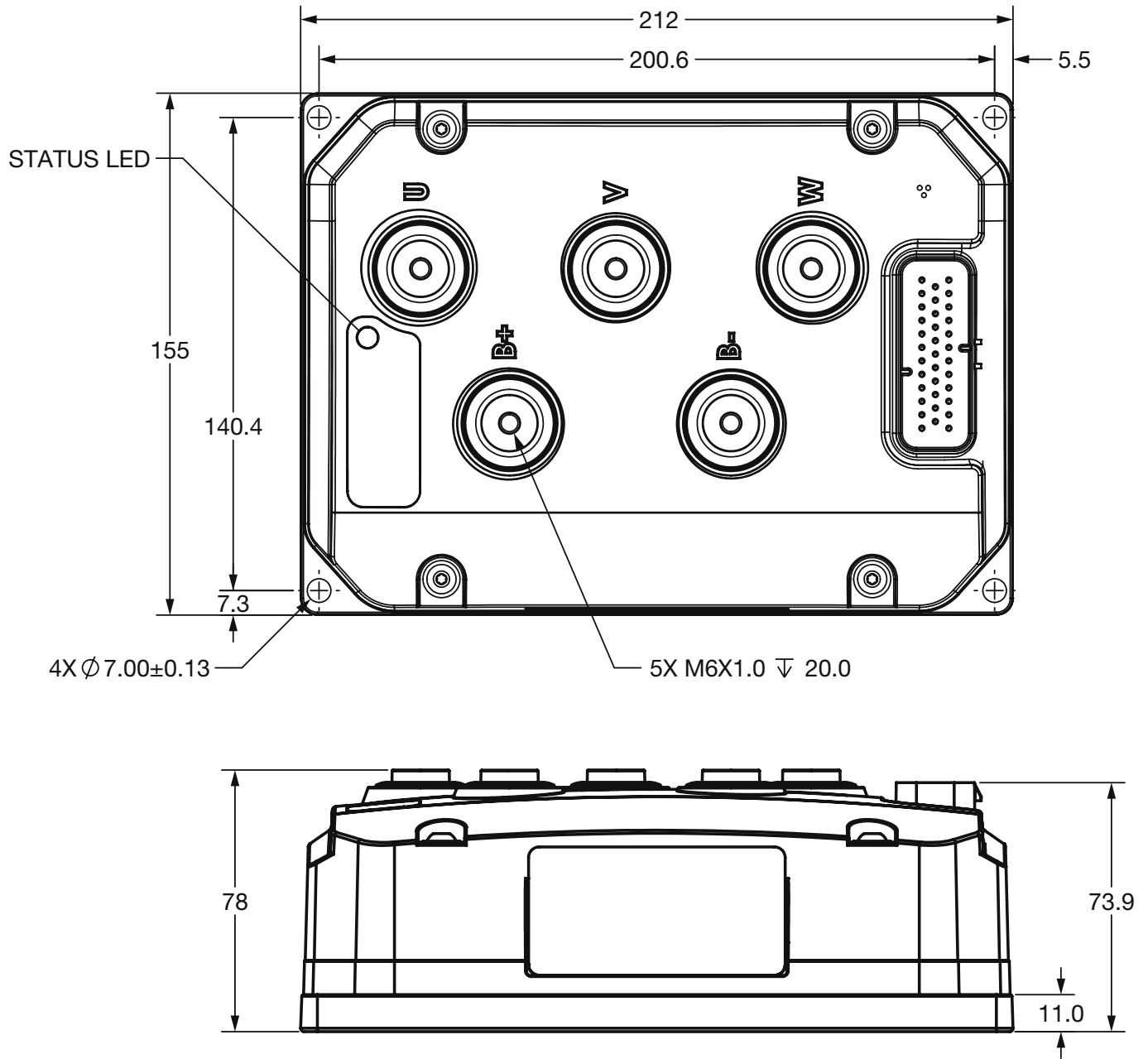



DIMENSIONS

AC F10-A

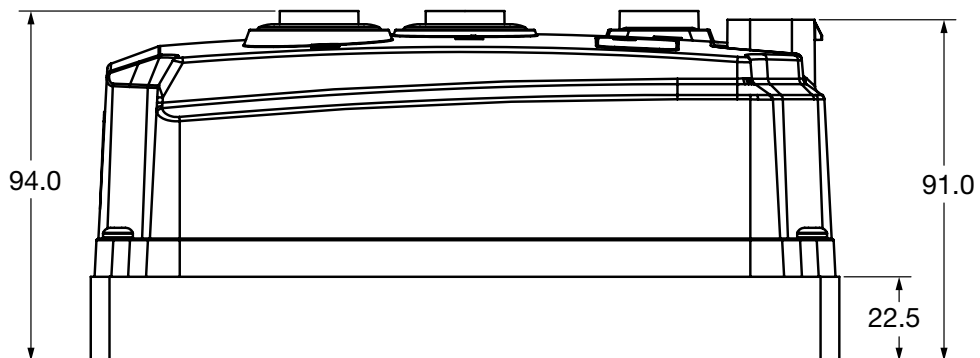
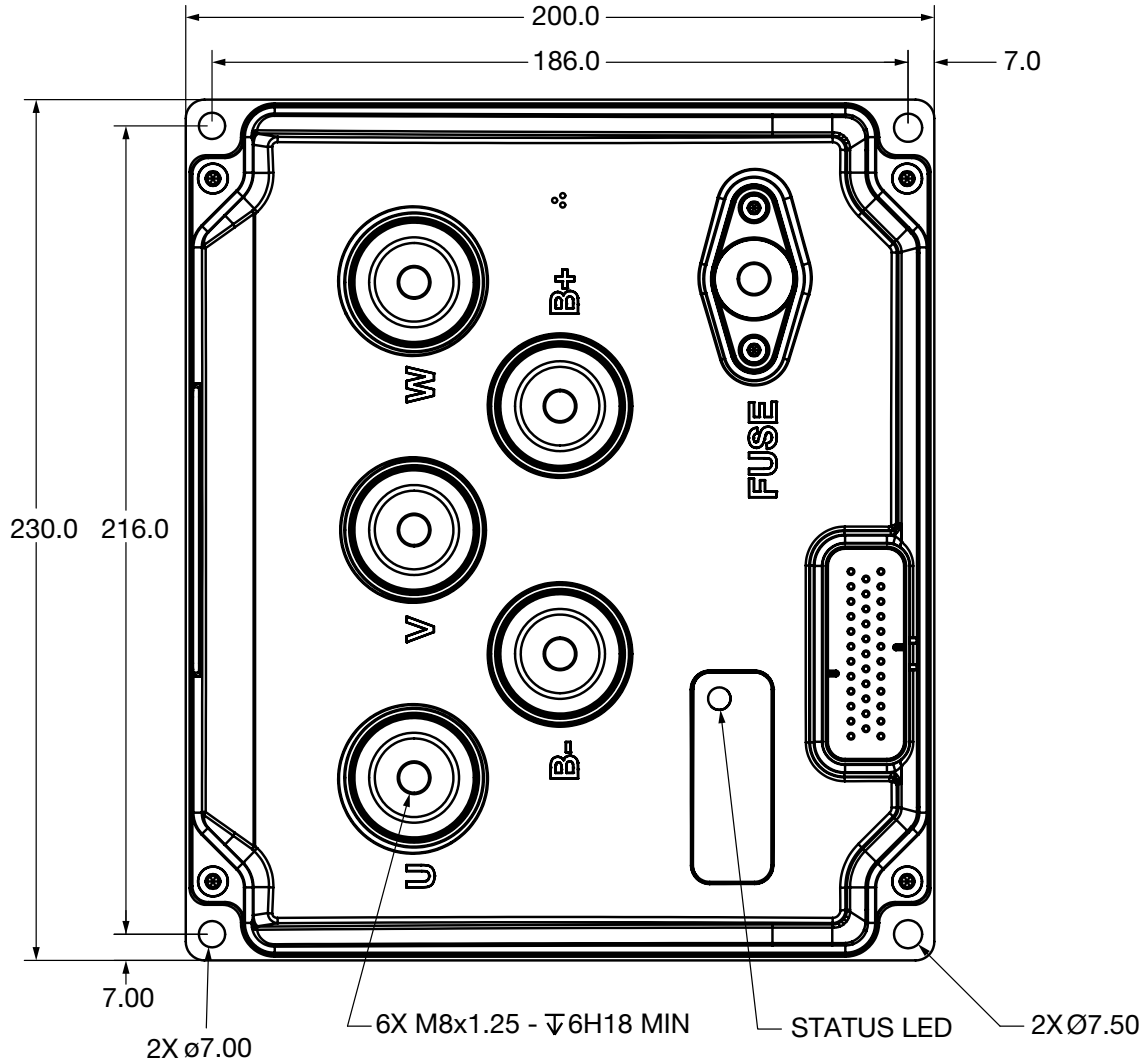



CONNECTOR WIRING

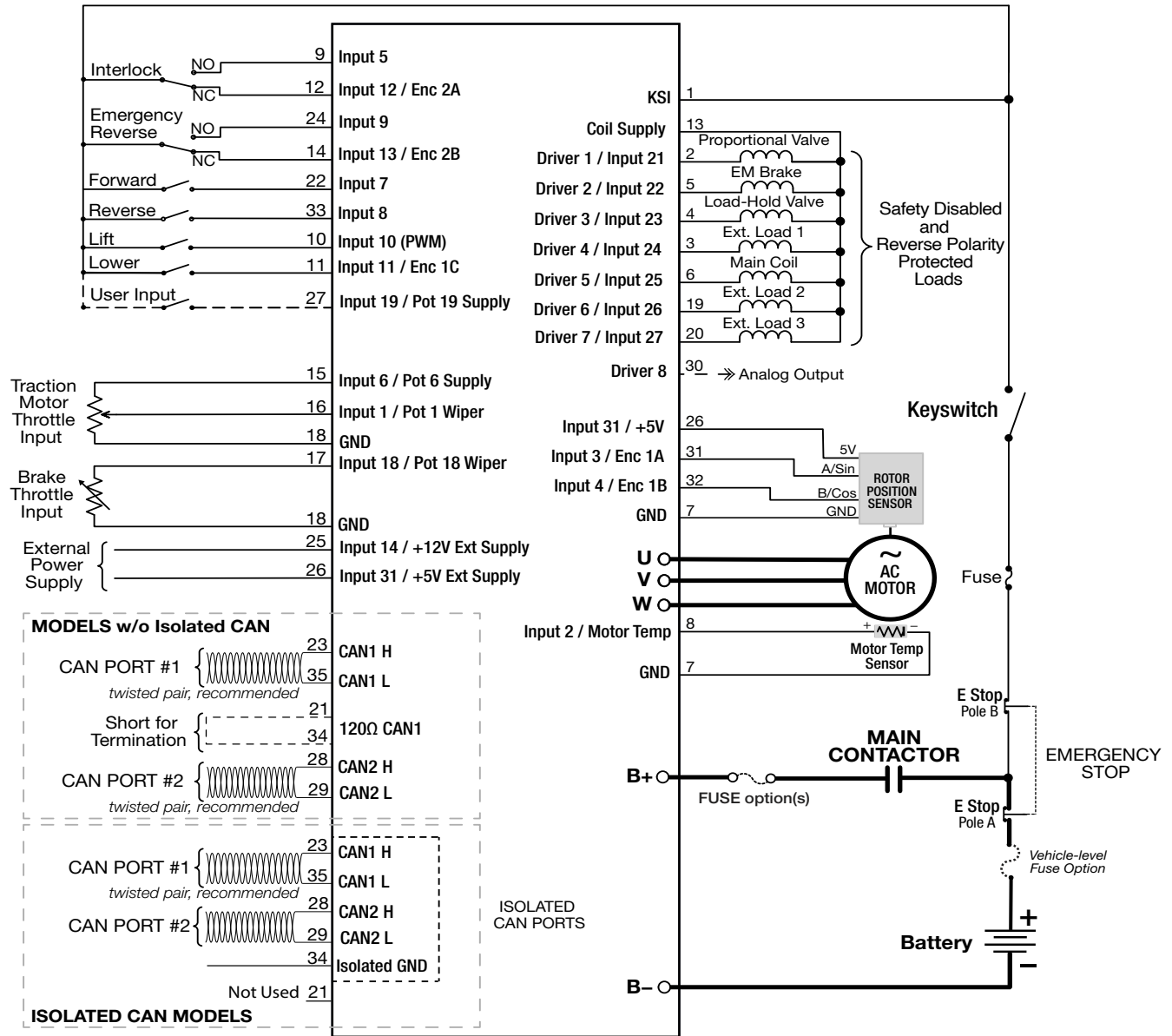

PINOUT CHART

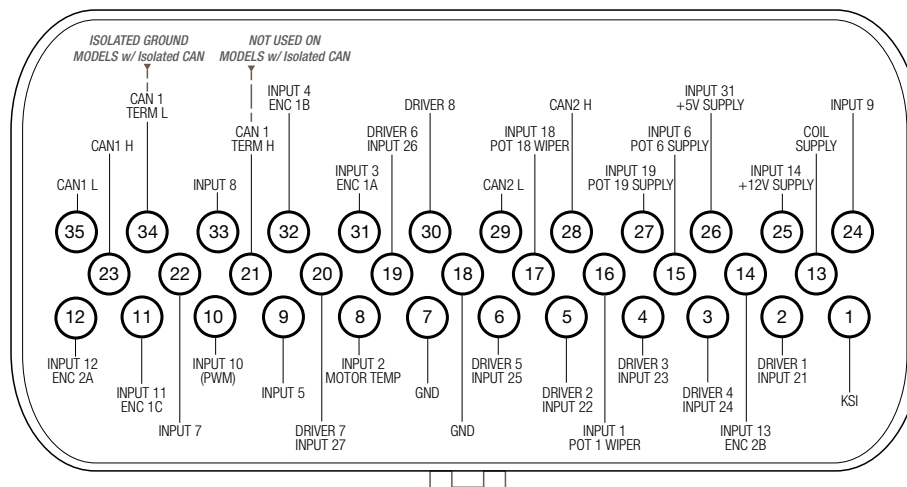



SPECIFICATIONS

Nominal Input Voltage	24V	24–36V	36–48V	48–60V	48–80V	72–96V
Minimum Voltage	12V	12V	18V	24V	24V	36V
Maximum Voltage	33V	50V	63V	75V	100V	120V
Design Life	20,000 Hrs	20,000 Hrs	20,000 Hrs	20,000 Hrs	20,000 Hrs	5,000 Hrs
PWM Frequency	10 kHz nominal (configurable)					
Maximum Controller Output Frequency	599Hz					
Electrical Isolation to Heatsink	500 VAC					
Storage Ambient Temperature	–40°C to 95°C					
Operating Ambient Temperature	–40°C to 50°C					
Thermal Cutback	Controller linearly reduces maximum current limit when the internal heatsink temperature is between 85°C and 95°C; complete cutoff occurs above 95°C and below –40°C.					
Ingress Protection	IP67					
EMC	Designed to the requirements of EN EN12895:2015+A1:2019					
Safety	Designed to the requirements of EN ISO 13849-1:2015 and EN 1175:2020					
UL	UL recognized component per UL583 (pending)					
	AC F4-A	AC F6-A	AC F10-A			
Weight	1.9 kg	3.1 kg	5.0 kg			
Dimensions W x L x H	180 mm x 140 mm x 75 mm	212 mm x 155 mm x 78 mm	230 mm x 200 mm x 94 mm			
Mounting	Clearance holes for 4X M6 Bolts					
Power Connections	5x M6x1.0	5x M6x1.0	6x M8x1.25			

Note: Regulatory compliance of the complete vehicle system with the controller installed is the responsibility of the vehicle OEM. Output frequencies above 599Hz are possible if required - please contact Curtis for further information.

WARRANTY Two year limited warranty from time of delivery.

The Curtis Difference

 You feel it when you drive it