

# SKF VectoLub, accessories

Accessories for the minimal quantity lubrication systems VTEC and VE1B

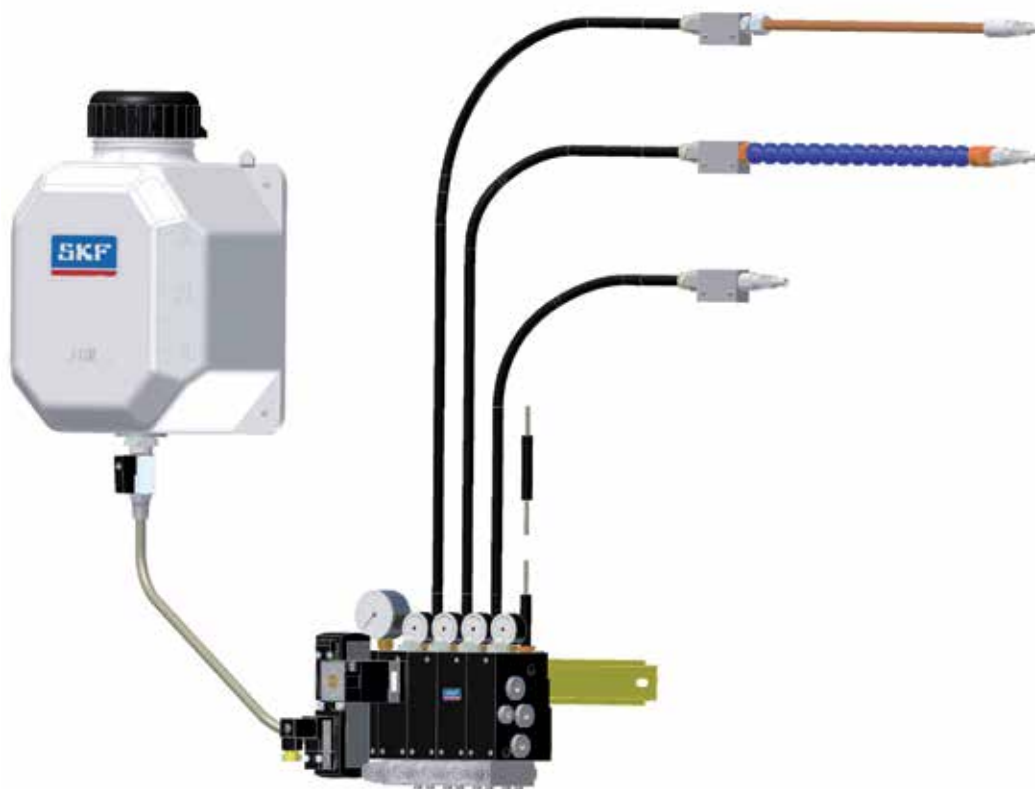

## Spray blocks

Every spraying unit is connected to the coaxial outlet of a VTEC or VE1B unit. It comprises:

- a spray block with a nozzle
- a coaxial line.

Several models of spray blocks are available to better meet the needs of the application. The main selection criteria of the blocks are:

- the shape of the jet of the nozzle
- the support of the nozzle (direct, articulated plastic tube, bendable copper tube)

### Bi-fluid nozzle

An air flow conducted through the coaxial tube is swirled at the lubricant outlet zone (lubricant coming out from the capillary tube). The air breaks down the lubricant into very fine droplets and sweeps them along to the lubrication point without forming mist. The microdroplet size (200/600  $\mu\text{m}$ ) ensures a perfect lubricant coating without atomization.

The special design keeps the jet from expanding and the lubricant is delivered to the lubrication point with pinpoint accuracy. As a result, contamination of the surroundings with excess lubricant is successfully prevented.

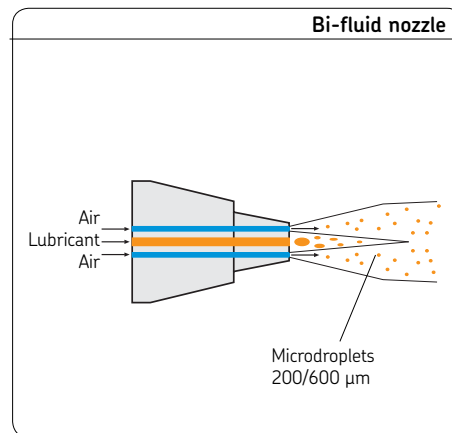

### Spray nozzles and applications

Circular fine jet	Circular jet	Wide jet	Annular jet	Multijet Special application
$\varnothing$ 10 mm Angle: ca. 10°	$\varnothing$ 20 mm Angle: ca. 20°	120 x 40 mm Angle: ca. 20/60°	$\varnothing$ 150 mm max. H = variable	Two modules are necessary to feed this spray block
Distance* = 50 mm	Distance* = 50 mm	Distance** = 100 mm	Eg.: $\varnothing$ 80 x H 14 mm Oil ISO VG 68 at 20°C	Adjustable according to the blade height
Drilling and machining	Drilling and machining	Drawing	Cylinder oiling	Sawing

\*) Test condition: carrier air pressure 0,3 bar, lubricant LUB 200, viscosity 90  $\text{mm}^2/\text{s}$  at 18 °C, micropump delivery rate: 5  $\text{mm}^3/\text{stroke}$  – 3 strokes/s

\*) Test condition: carrier air pressure 0,3 bar, lubricant viscosity 114  $\text{mm}^2/\text{s}$  at 18 °C, micropump delivery rate: 5  $\text{mm}^3/\text{stroke}$  – 3 strokes/s

#### Order information

##### Spray block

	Order No.	Direct nozzle	Nozzle and articulated plastic tube	Nozzle and bendable copper tube
Circular fine jet	AC-4755-C2	•		
	AC-4531-C2		•	
	AC-4529-C2			•
Circular jet	AC-3539-C2	•		
	AC-3252-C2		•	
	AC-3184-C2			•
Wide jet	AC-4255-C2	•		
	AC-4256-C2		•	
	AC-3485-C2			•
Annular jet	AC-3790-C2			•
Multijet	AC-3885-C2	•		

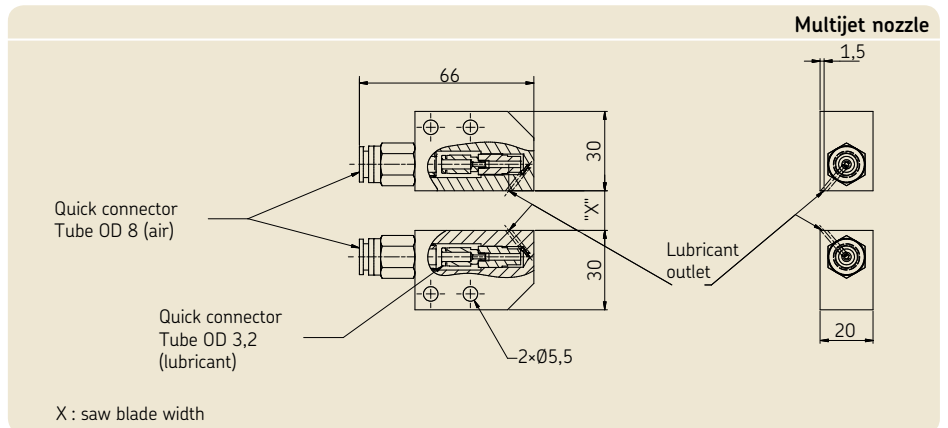
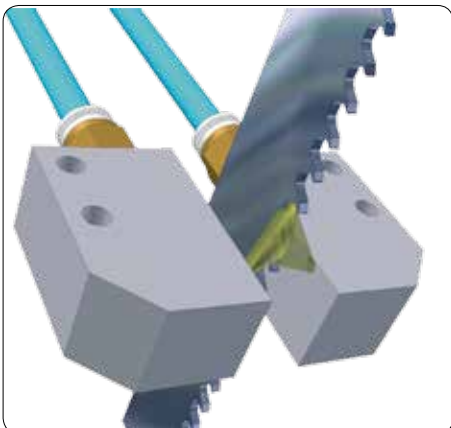
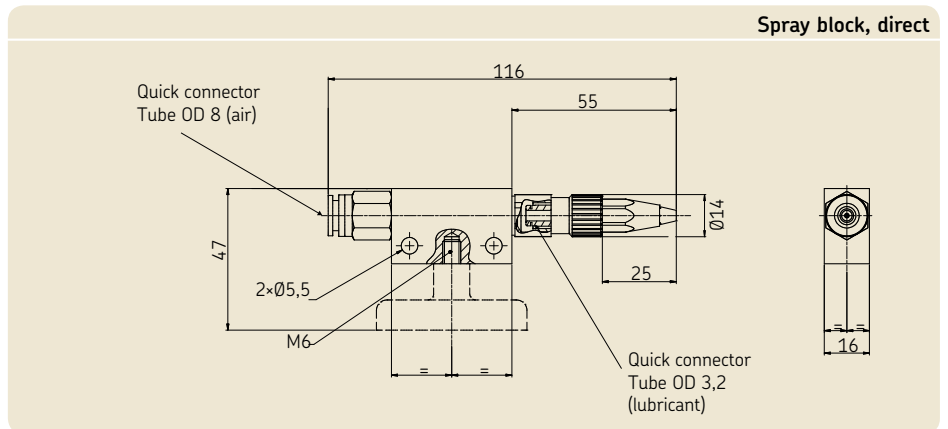
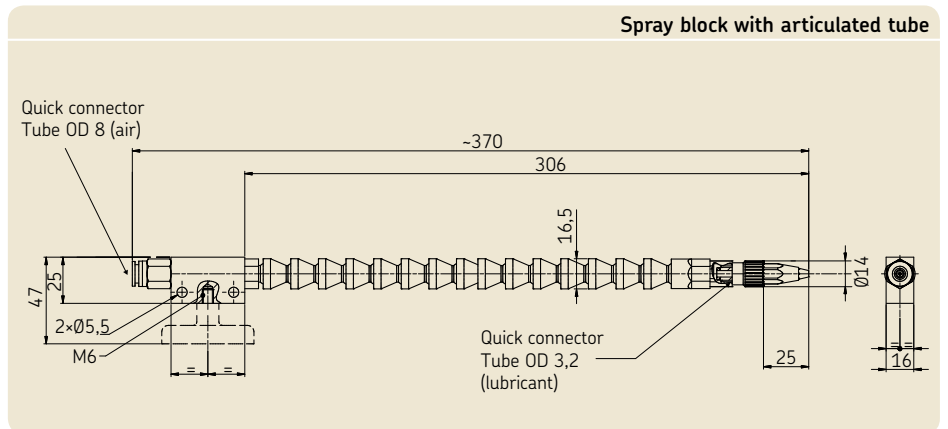
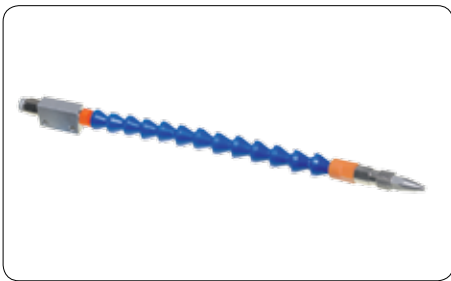
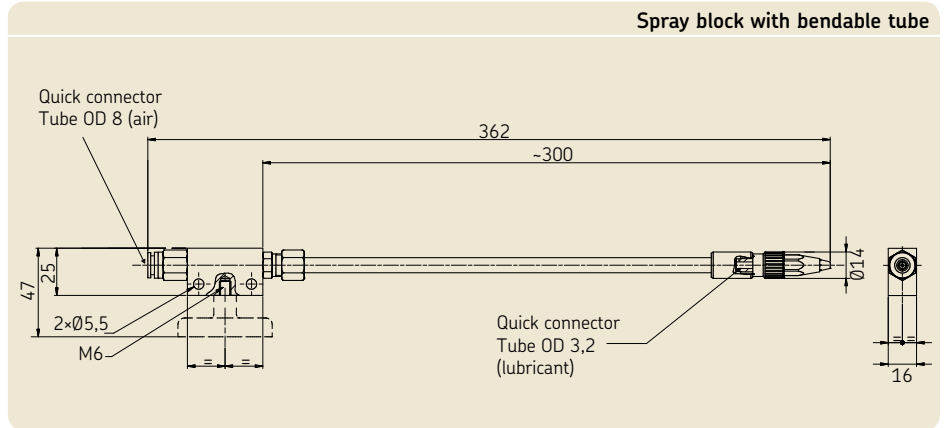
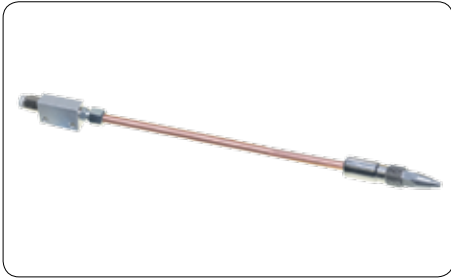

## Coaxial lines

Spray blocks are connected to the SKF VectoLub unit by means of coaxial lines. The lubricant flows through the capillary tube of the line and the carrier air through the outer tube.

Every connection is done with quick connectors.

A specific tool\* has been designed to easily dismount the coaxial line.

\*) This tool is always delivered with every SKF VectoLub unit.

### • Flexible line – type T

- Outer tube, polyurethane, section  $\varnothing 8 \times 1,25$
- Capillary, polyamide, section  $\varnothing 3,2 \times 0,5$
- Bend radius: 60 mm
- Service temperature: 10 to 60 °C

### • Reinforced line – type F

- Outer tube, rubber with metal brading, section  $\varnothing 13 \times 2,75$  with shell for quick connector for tube  $\varnothing 8$
- Capillary in polyamide, section  $\varnothing 3,2 \times 0,5$
- Bend radius: 90 mm
- Service temperature: 10 to 60 °C

## Accessory

Magnetic foot to fit the spray block.

Order No. . . . . **AC-3247**

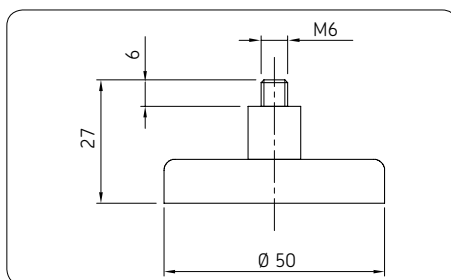

## Order information for a spraying unit (spray block + coaxial line)

Three points have to be taken into account to determine the order no. of a complete spraying unit SKF VectoLub.

1. The spray block for every lubrication point. Selection according to the jet shape and the type of nozzle (direct, with articulated plastic tube or with bendable copper tube).
2. Selection of the coaxial line, light **T** or strong **F** and the length.
3. Standard fixation with screws – no indication. Fixation with movable magnetic foot – indicate **M**.

Every SKF VectoLub unit is systematically delivered with quick connectors for air and lubricant inlets, as well as a specific tool to easily dismount the coaxial line.

### Order example

#### Spraying unit

Order No. **AC-4529-C2 – F2500 – M**

1. **Nozzle** —————
2. **Coaxial line + length** —————  
 standard lengths [mm]: 1 000,  
 1 500, 2 000, 2 500, 3 000,  
 3 500, 4 000, 4 500, 5 000
3. **Fixation** —————

Example: circular fine jet nozzle with bendable copper tube, reinforced coaxial line, length 2 500 mm, fixation with magnetic foot.

## Lubricant reservoirs

Lubricant reservoir for SKF VectoLub units with a capacity of 1 / 3,5 / 6 or 10 liters.

- Material: polyethylene (PE), polyamide (PA) or aluminium; fixing bracket in steel (zinc chromate plating).
- Visual lubricant level monitoring.
- Float level switch for minimal lubricant level monitoring (option).
- Strainer at the outlet port.
- Stopcock to isolate the reservoir in case of maintenance work on the SKF VectoLub unit.
- Supply line to the VTEC unit, polyamide tube  $\varnothing 8 \times 1$  length 3 m, outlet port with quick connector, complete connection kit delivered with every reservoir.

### Order information

#### Reservoirs

Order No.	Useful capacity [l]	Material	Level switch	Outlet filter [ $\mu\text{m}$ ]	Service temperature [ $^{\circ}\text{C}$ ]	ca. max. weight [kg]
MOD-030	1	PA (Polyamide)	–	55	–10 to +60	0,67
MOD-030-NC			•			
MOD-031	3,5	PE (Polyethylene)	–	200	–10 to +60	0,14
MOD-031-NC			•			
MOD-032	6	PA6 (Polyamide)	–	200	–10 to +80	0,35
MOD-032-NC			•			
MOD-033	10	aluminum	–	200	–10 to +60	6,55
MOD-033-NC			•			

See important product usage information on the back cover.



### Level monitoring MOD-030-NC

Lubricant minimal level monitoring

- NO switch, opens when minimal level is reached
- Voltage max. 250 V – 50/60 Hz
- Switching capacity: 10 VA
- Intensity max.: 0,25 A
- Protection: IP 65 with connector

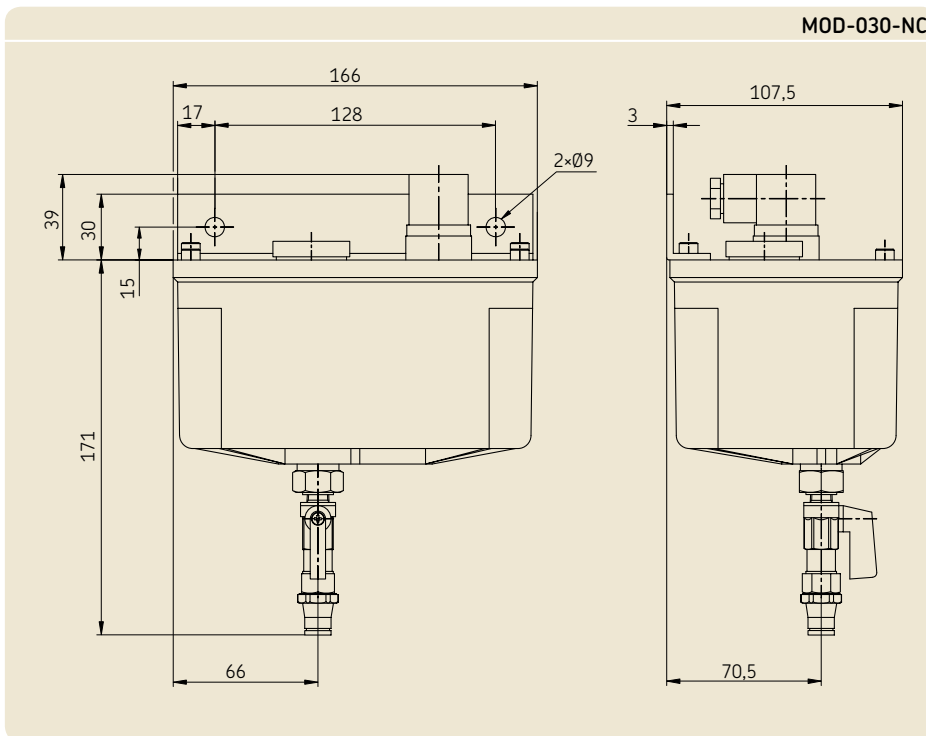

### Level monitoring MOD-031-NC

Lubricant minimal level monitoring

- NO switch, opens when minimal level is reached
- Voltage max. 250 V – 50/60 Hz
- Switching capacity: 10 VA
- Intensity max.: 0,5 A
- Protection: IP 65 with connector

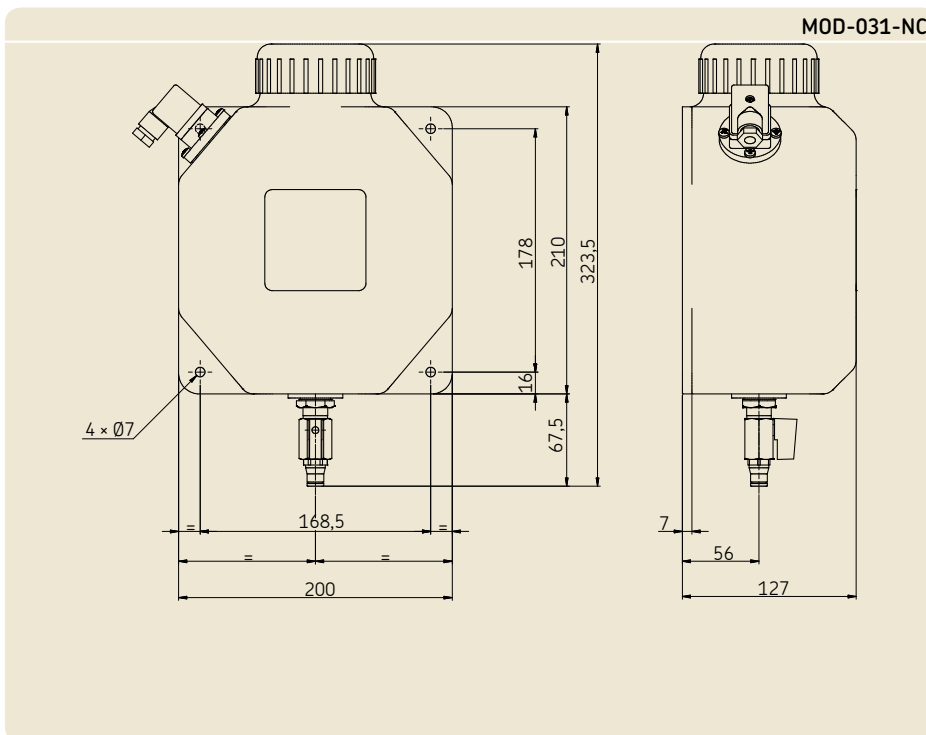



### Level monitoring MOD-032-NC

Lubricant minimal level monitoring

- NO switch, opens when minimal level is reached
- Voltage max. 250 V – 50/60 Hz
- Switching capacity: 10 VA
- Intensity max.: 0,7 A
- Protection: IP 65 with connector

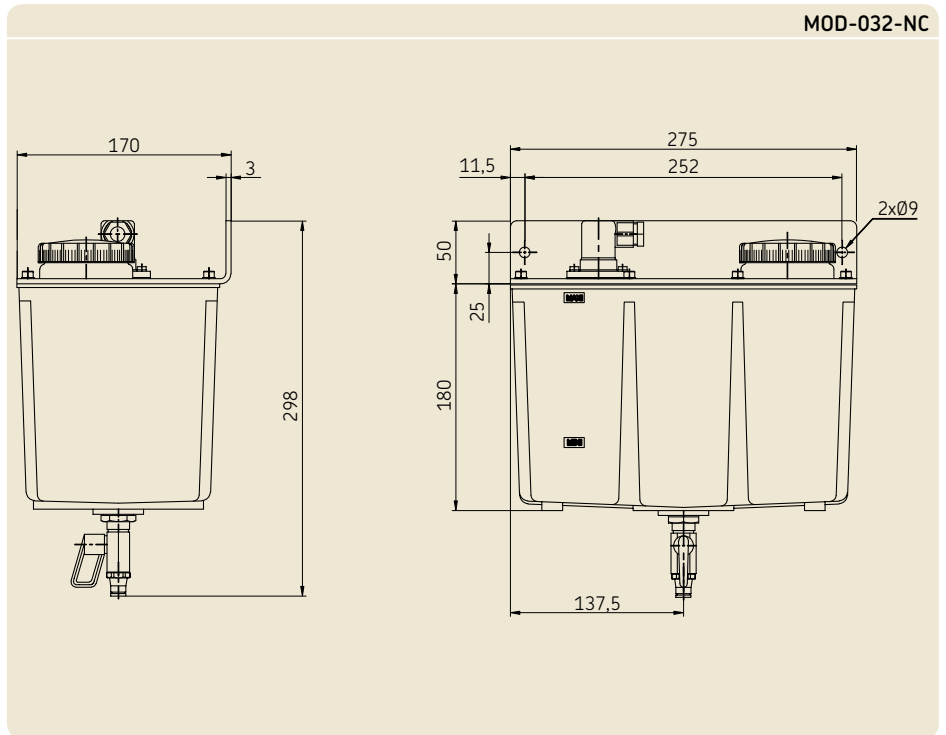

### Level monitoring MOD-033-NC

Lubricant minimal level monitoring

- NO switch, opens when minimal level is reached
- Voltage max. 250 V – 50/60 Hz
- Switching capacity: 10 VA
- Intensity max.: 0,8 A
- Protection: IP 65 with connector

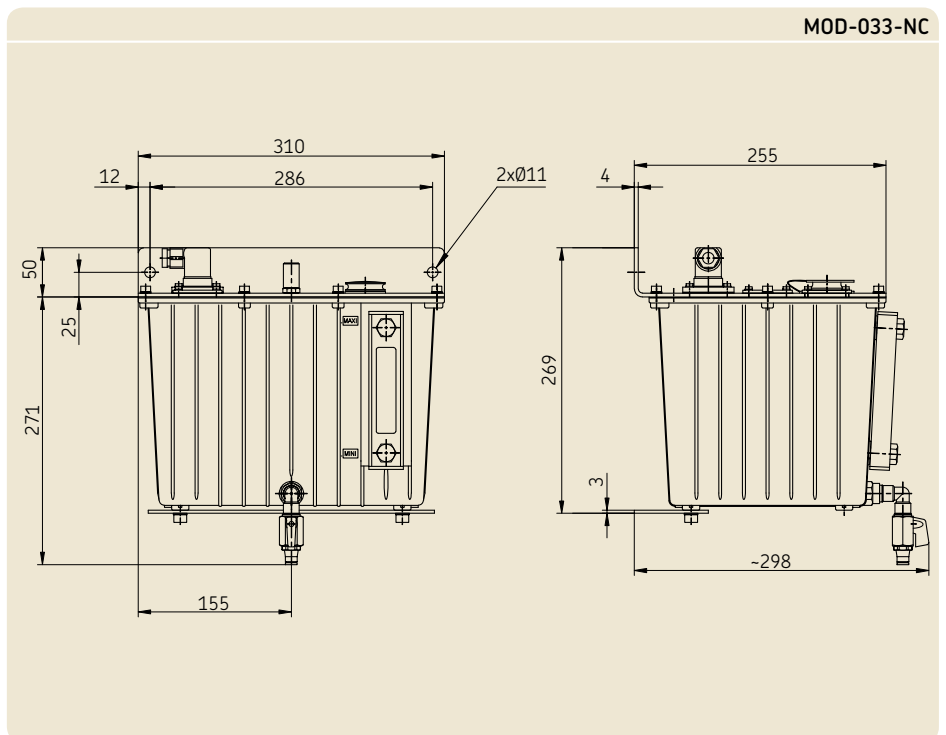

**Order No.: 1-4402-EN**

Subject to change without notice! (02/2015)

**Important product usage information**

All products from SKF may be used only for their intended purpose as described in this brochure and in any instructions. If operating instructions are supplied with the products, they must be read and followed.

Not all lubricants are suitable for use in centralized lubrication systems.

SKF does offer an inspection service to test customer supplied lubricant to determine if it can be used in a centralized system. SKF lubrication systems or their components are not approved for use with gases, liquefied gases, pressurized gases in solution and fluids with a vapor pressure exceeding normal atmospheric pressure (1013 mbars) by more than 0,5 bar at their maximum permissible temperature.

Hazardous materials of any kind, especially the materials classified as hazardous by European Community Directive EC 67/548/EEC, Article 2, Par. 2, may only be used to fill SKF centralized lubrication systems and components and delivered and/or distributed with the same after consulting with and receiving written approval from SKF.

**Further brochures**

1-9201-EN Transport of Lubricants in Centralized Lubrication Systems

This brochure was presented by:

® SKF and VectoLub are registered trademarks of the SKF Group.

© SKF Group 2015

The contents of this publication are the copyright of the publisher and may not be reproduced (even extracts) unless prior written permission is granted. Every care has been taken to ensure the accuracy of the information contained in this publication but no liability can be accepted for any loss or damage whether direct, indirect or consequential arising out of the use of the information contained herein.

