

Sectional metering devices

# Product series VPK

For oil and grease

For use in SKF CircOil circulating and SKF ProFlex progressive centralized lubrication systems



## Fields of application

- Metal-forming machinery
- Vehicles
- Construction machinery
- Production systems in the automotive industry
- Packaging and printing machines

## Advantages

- For universal use in continuous or intermittent operations
- Versatile – features metering sections with variable dosing amounts and internal and external consolidation of outlets
- Expandable by attaching directional solenoid valves

- Can be monitored using piston detectors or visual cycle indicators
- Simple to service – separator plates feature vulcanized seals that cannot be detached
- Powerful – max. 20 outlets for volumetric flow of up to 500 cm<sup>3</sup>/min

# Table of contents

Product overview . . . . .	3
Product description . . . . .	4
Monitoring and attachments . . . . .	5
Sectional metering device VPK in basic design . . . . .	6
Sectional metering device VPK with piston detector and cycle indicator . . . . .	7
Sectional metering device VPK with cycle indicator and NAMUR proximity switch . . . . .	8
Sectional metering device VPK with directional solenoid valve . . . . .	9
Order code . . . . .	10–11
Order example . . . . .	12
Accessories . . . . .	13
Exploded view . . . . .	14
Spare parts . . . . .	14–16



### Important information on product usage

SKF and Lincoln lubrication systems or their components are not approved for use with gases, liquefied gases, pressurized gases in solution and fluids with a vapor pressure exceeding normal atmospheric pressure (1 013 mbar) by more than 0,5 bar at their maximum permissible temperature.



CAD models for the products shown in this brochure can be downloaded at: [skf-lubrication.partcommunity.com](http://skf-lubrication.partcommunity.com)

# Sectional metering device, product series VPK

## Product overview

Basic design



Visual cycle indicator



Piston detector



NAMUR proximity switch



4/2-Directional solenoid valve



2/2-Directional solenoid valve



Overview SKF progressive feeders, inlet volume

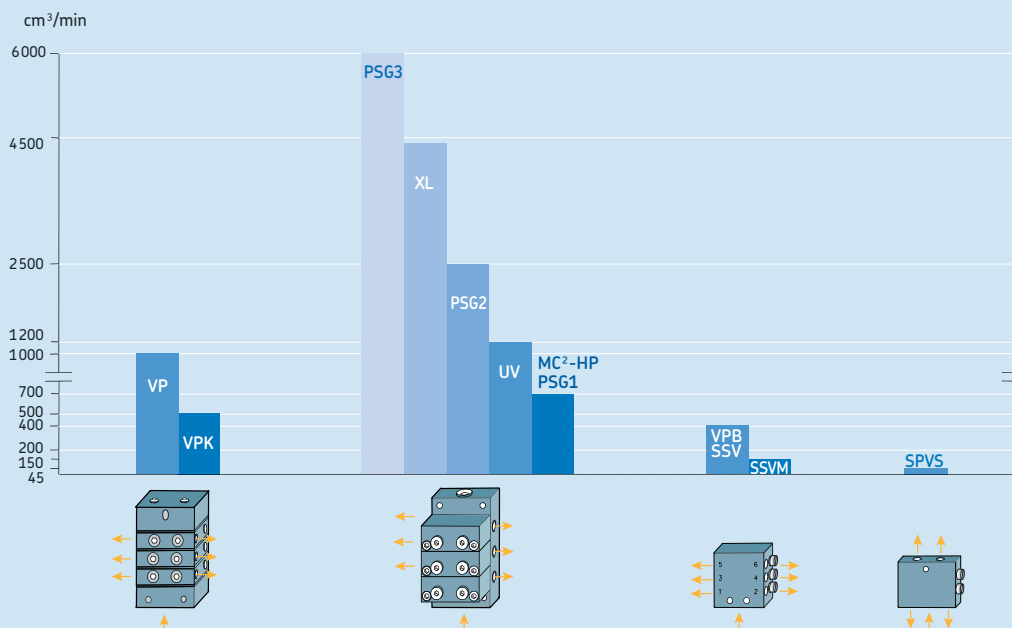

The maximum recommended flow rate values relate to lubricating oil at the highest selectable piston-stroke volume.

# Sectional metering device, product series VPK

## Product description

### General

The sectional metering device VPK, which belongs to the progressive feeder range, is available in the designs VPKM (metric-threaded connectors) and VPKG (inch-threaded connectors). With their metering sections, VPM and VPG cover a metering volume per outlet and cycle of 0.05 cm<sup>3</sup> (T-section) to 0.6 cm<sup>3</sup> (S-section). The inlet of the feeder is located at an inlet section and the outlets are at the downstream feeder sections. The delivery ducts are sealed by elastic seals. An end section is located downstream of the last feeder section. All sections are interconnected with tie-rods. They seal the feeder assembly.

The volumetric flow, which is sent via a tube, is forcibly distributed in a predetermined ratio to the outlets, i.e. to the lubrication points or the downstream progressive feeders. Pistons, which are aligned in series, meter the lubricant for two opposite outlets each and control the function of the neighboring piston. This way, the function of the sectional metering device can be checked by monitoring any piston with a cycle indicator or a piston detector.

### Operation (→ Fig. 1)

The task of the progressive feeder is to distribute consecutively specified portions of the pressure-fed lubricant (grease or oil) to the connected lubrication points.

The discharge of the lubricant continues as long as it is pressure-fed to the progressive feeder. The specified portions are generated through the piston movement. Two lubricant outlets on the two end positions of the piston travel are allocated to each piston.

The number of pistons within a feeder is from 3–10 variable. If lubricant is pressure-fed, the pistons of a feeder move in turn to their end position. The piston movement displaces a portion of the lubricant that is downstream of the piston to the downstream outlet. The movement of a piston can only start after the upstream piston has been moved to its end position. If all pistons are in their left or right end position, internal connecting bores in the feeder ensure a defined and continued running of the pistons.

When all pistons have been moved once to the left as well as to the right end position, all connected lubricant points have

been supplied once with the preset lubricant quantity.

The portions for both outlets are determined by the diameter and the travel of the piston. The selection of the required portion is made during the design of the feeder.

A subsequent change of the portions is only possible through a modification of the feeder.

### Information on the design

The general criteria for the design of progressive feeders also apply without restrictions to the sectional metering device VP. The most important criterion is the number of cycles (stroke rate). They should be held as low as possible by selecting high-volume feeders. Maximum value of 200 cycles/min should not be exceeded

Thus, pressure losses and noise level will also be reduced. In case of an installation on movable machine parts or in case of strong vibrations (e.g. on presses), the piston position of the feeder should not be the same as the direction of movement of the machine part.

For the VPK feeder, the minimum number of feeder sections is 3 and the maximum number is 10.

### Quantity distribution

Sectional metering devices distribute an amount delivered by a pump to several outlets while the feeder determines the volumetric ratio.

The different output quantities within a feeder are achieved by the use of various piston diameters or the joining of two or more outlets. The indicated lubricant quantities result from the piston diameter and the maximum travel of the piston. Depending on the system design, these capacities may vary by 40 percent.

For the sectional metering devices VPKM and VPKG, sections for two connections (**T** = twin) or for one connection (**S** = single) are available. In case of single sections, the two opposite outlets are connected internally, whereby one outlet is closed.

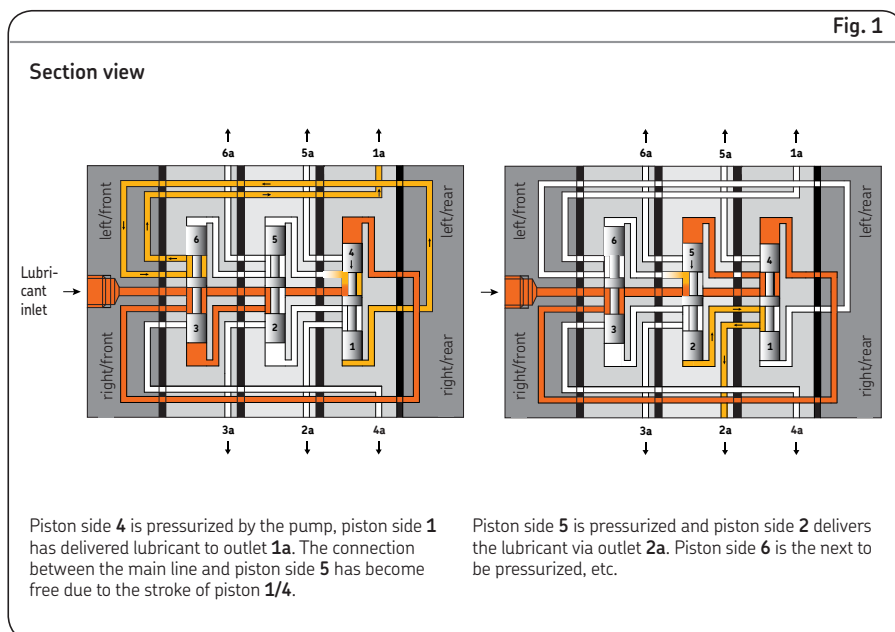

# Sectional metering device, product series VPK

## Monitoring and attachments

### Tightening torques

During the installation of the VKP feeder, consisting of inlet section, inlet plate, twin and single sections, separator plates as well as end plate and end section, the following tightening torques have to be adhered to for the tie-rods and nuts:

#### Tightening torque

Tie-rod (2x)	each	2,4 Nm
Nut for tie-rod M6 (2x)	each	9,0 Nm

### Monitoring

All standard sections can be monitored directly by means of a piston detector. Furthermore, the piston movement can be monitored by visual stroke monitoring.

Both monitoring models can be used for oil as well as for grease.

### Attachments

The sectional metering device VPK can be equipped with upstream directional solenoid valves for oil.

### Check valves

Screw unions with check valves are recommended when using greases due to the air inclusions caused by production processes.

### Consolidation of outlets (→ Fig. 2)

Two neighboring outlets are joined from the end section towards the inlet section. The plug (order No. **917-006-101**) of the outlet nearest to the end section must be unscrewed and the outlet bore must be sealed with a screw plug. The fluid of the two outlets will then flow out of the outlet near the inlet section.

#### Note:

To avoid damages the feeder section behind the inlet section must not be closed!

#### Important!

To avoid damages it is absolutely essential, that the plug (order No. **917-006-101**) has been removed before screwing in the screw plug, otherwise the feeder may block.

This consolidation of outlets can be combined, as long as there is no single section in-between. The single section completes the group formation; a new group formation can only be carried out behind the single section. If it turns out that the fluids of two neighboring outlets have to be separated again (e.g. due to an additional lubrication point), this will be a simple matter. The only thing to do is to screw in a plug (order No. **917-006-101**) and to connect the previously closed outlet to the new lubrication point.

Fig. 2

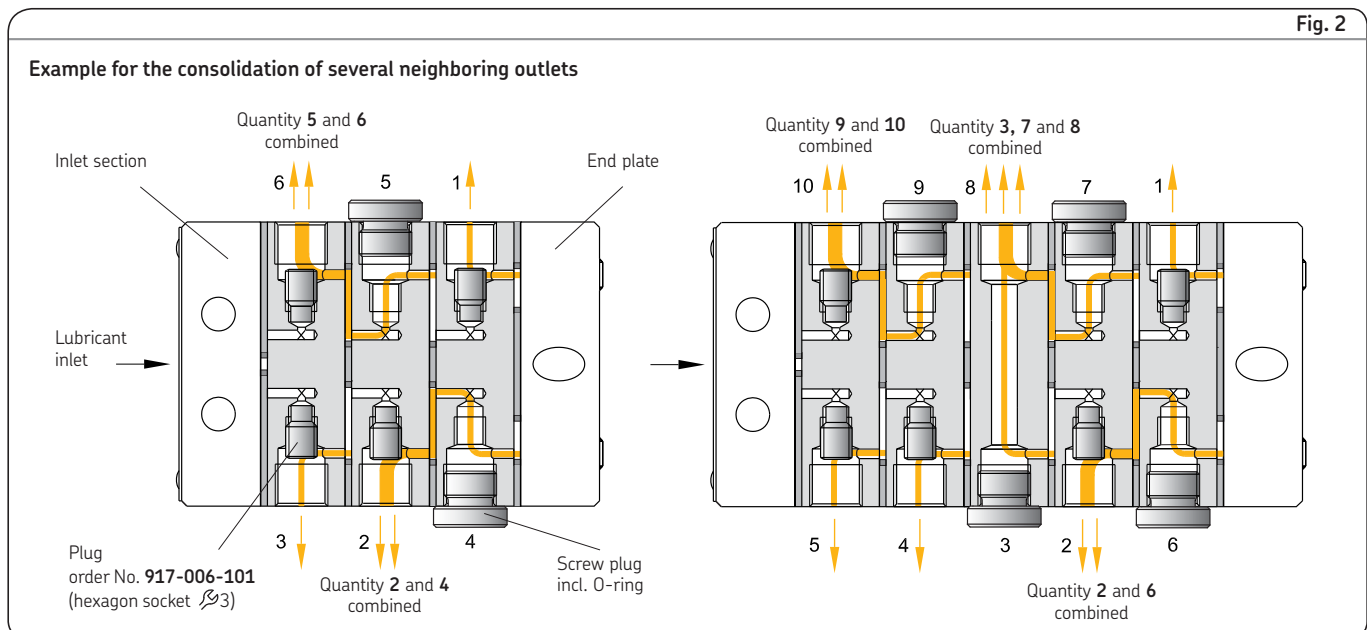

# Sectional metering device, product series VPK

## Basic design for oil and grease



### Technical data

Type . . . . . Hydraulically controlled  
 Mounting position . . . . . Any  
 Ambient temperature range . . . . . -25 to +90 °C  
 Feeder section. . . . . → Table 1  
 Occupied outlets. . . . . 1 to 20

### Material

Inlet, separator and end section . . . . . Steel, galvanized, NBR  
 Sections . . . . . Steel, galvanized

### Hydraulic system

Operating pressure, max. . . . . Oil 200 bar, grease 300 bar  
 Volume per outlet and cycle . . . . . → Table 2  
 Lubricant . . . . . Mineral oils, greases based on mineral oil, environmentally friendly and synthetic oils and greases  
 Operating viscosity . . . . . > 12 mm<sup>2</sup>/s  
 Worked penetration . . . . . ≥ 265 x 0.1 mm (up to NLGI Grade 2)

### VPK sectional metering device, basic design

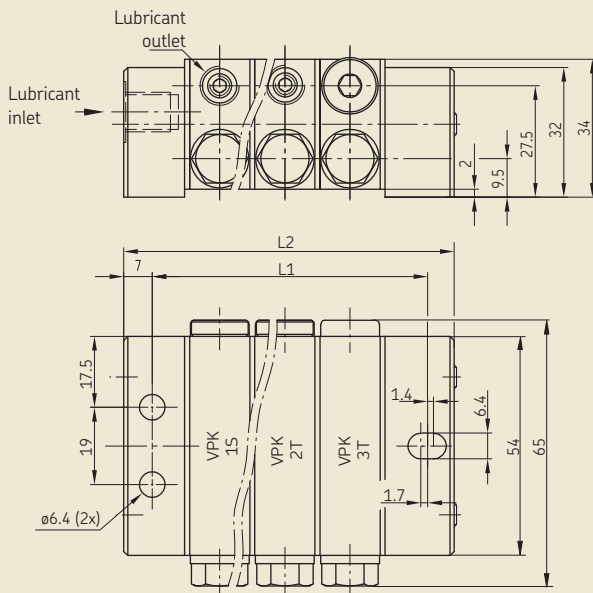

Table 1

### Dimensions

Inlet: VPKM = M10×1  
 VPKG = G1/8  
 Outlet: VPKM = M10×1  
 VPKG = G1/8

Typ	Number of feeder sections	Number of possible outlets	L1 [mm]	L2 [mm]	Weight [kg]
VPKM-3 / VPKG-3	3	6	68.4	81.9	0.99
VPKM-4 / VPKG-4	4	8	84.6	98.1	1.18
VPKM-5 / VPKG-5	5	10	100.8	114.3	1.38
VPKM-6 / VPKG-6	6	12	117.0	130.5	1.57
VPKM-7 / VPKG-7	7	14	133.2	146.7	1.77
VPKM-8 / VPKG-8	8	16	149.4	162.9	1.96
VPKM-9 / VPKG-9	9	18	165.6	179.1	2.16
VPKM-10 / VPKG-10	10	20	181.8	195.3	2.35

Table 2

### Selection of feeder sections

Quantity per cycle and outlet [cm <sup>3</sup> ]	Number of outlets	Description of the sections	Identification letter/Order code
0.05	2	05T	A
0.10	2	1T	C
0.20	2	2T	E
0.30	2	3T	G
0.10	1	05S	B
0.20	1	1S	D
0.40	1	2S	F
0.60	1	3S	H

# Sectional metering device, product series VPK

## Monitoring with piston detector and cycle indicator, for oil and grease

With piston detector



With cycle indicator



### Technical data

Basis design → Technical data page 6

#### Piston detector, electrical <sup>1)</sup>

Ambient temperature range . . . . .	-25 to +80 °C
Operating pressure max. . . . .	350 bar
Design . . . . .	4-point LED
Rated voltage . . . . .	10 to 36 V DC
Internal thread . . . . .	M10×1
Weight . . . . .	30 g
Residual ripple (2-pin) . . . . .	3 bis 15 %
Residual ripple (3-pin) . . . . .	≤ 10 %
Max. load current . . . . .	100 mA
Protection class . . . . .	IP67
Min. load current (2-pin) . . . . .	4 mA
Outlet function (2-pin) . . . . .	NC contact
Outlet function (3-pin) . . . . .	PNP contact

#### Cycle indicator, visual

Ambient temperature range . . . . .	-15 to +75 °C
Weight . . . . .	30 g

<sup>1)</sup> The piston detector is designed for a service life of approx. 10-15 million cycles. This value may be significantly exceeded depending on the application, external environmental influences, medium, pressure, and cycle speed. Please contact the manufacturer if in doubt.

**Note!** Electrical plug and socket connections are ordered separately → page 13.

Sectional metering device VPK with piston detector

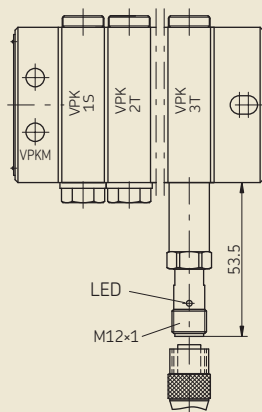

Sectional metering device VPK with visual cycle indicator

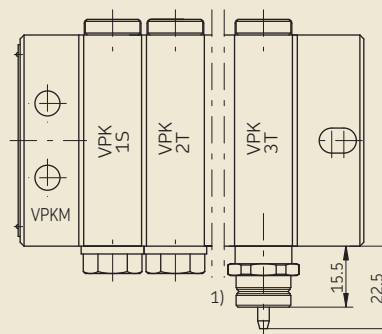

<sup>1)</sup> The installation of the cycle indicator with or without proximity switch is only possible from feeder section 2T/2S or larger.

# Sectional metering device, product series VPK

Monitoring with cycle indicator and NAMUR proximity switch, for oil and grease

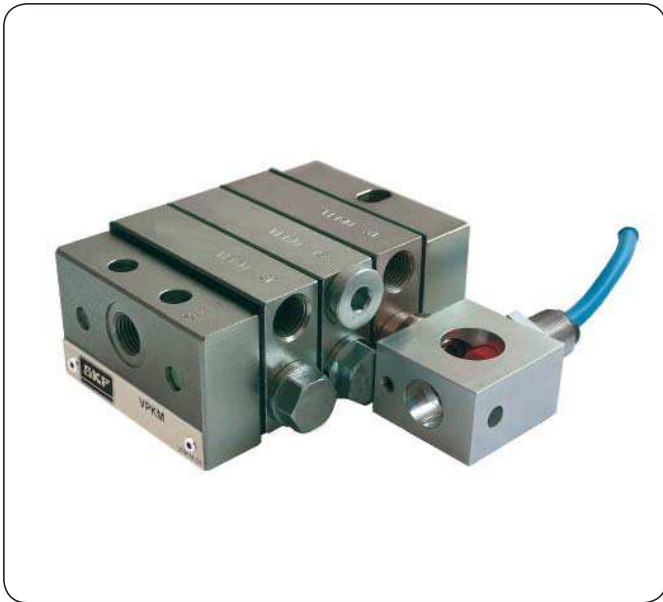

### Technical data

Basis design → Technical data page 6

#### Proximity switch

Ambient temperature range . . . . .	-15 bis +70 °C
Operating pressure max. . . . .	350 bar
Rated voltage . . . . .	8,2 V DC
Internal thread . . . . .	M12×1
Weight . . . . .	30g
Design . . . . .	PVC,
	with 2 m cable 2x 0.34 mm <sup>2</sup>
Power consumption . . . . .	conducting > 2.2 mA,
	blocking < 1.0 mA
Protection class . . . . .	IP 67
Outlet function . . . . .	Öffner normal geschlossen (NC)

Weight total . . . . . 85 g  
(Cycle indicator, housing, proximity switch)

#### Note!

Use proximity switch only with NAMUR switching amplifier.

### Sectional metering device VPK with proximity switch

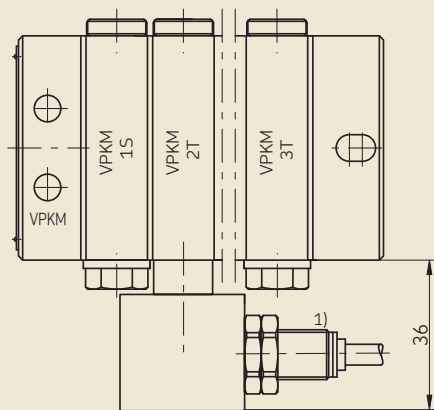

<sup>1)</sup> The installation of the cycle indicator with or without proximity switch is only possible from feeder section 2T/2S or larger.



# Sectional metering device, product series VPK

with directional solenoid valve, for oil

With 4/2-directional solenoid valve



With 2/2-directional solenoid valve



Sectional metering device VPK with 2/2-directional solenoid valve

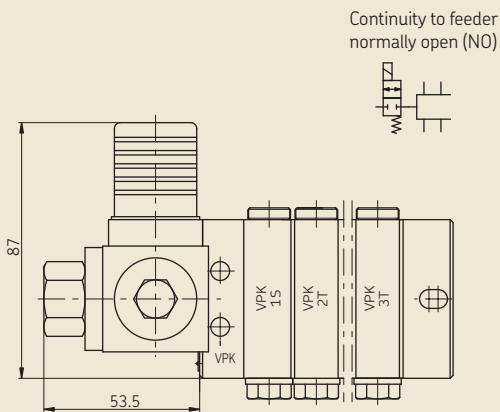

## Technical data

### Basis design → Technical data page 6

#### 3/2- and 4/2-directional solenoid valve

Ambient temperature range . . . . .	-15 to +75 °C
Operating pressure max. . . . .	150 bar
Rated voltage . . . . .	24 V DC
Rated current . . . . .	1.3 A
Weight . . . . .	1560 g
Lubricant . . . . .	Mineral oils, environmentally friendly and synthetic oils
Operating viscosity . . . . .	20–1000 mm <sup>2</sup> /s
Elektrische Bauart . . . . .	Pusher/solenoid
Plug/electrical connection . . . . .	DIN EN 175301-803
ON-time . . . . .	100% ED
Protection class . . . . .	IP65
Design . . . . .	4/2 continuity to feeder normally open (NO); 3/2 continuity to feeder normally closed (NC)

#### 2/2-directional solenoid valve (only for VPKG)

Ambient temperature range . . . . .	-15 to +75 °C
Operating pressure max. . . . .	150 bar
Rated voltage . . . . .	24 V DC
Rated current . . . . .	1.3 A
Weight . . . . .	610 g
Lubricant . . . . .	Mineral oils, environmentally friendly and synthetic oils
Operating viscosity . . . . .	20–1000 mm <sup>2</sup> /s
Elektrische Bauart . . . . .	Pusher/solenoid
ON-time . . . . .	100% ED
Plug/electrical connection . . . . .	DIN EN 175301-803
Protection class . . . . .	IP65
Design . . . . .	Continuity to feeder normally open (NO)

**Note!** Electrical plug and socket connections are ordered separately → **page 13**.

Sectional metering device VPK with 4/2-directional solenoid valve

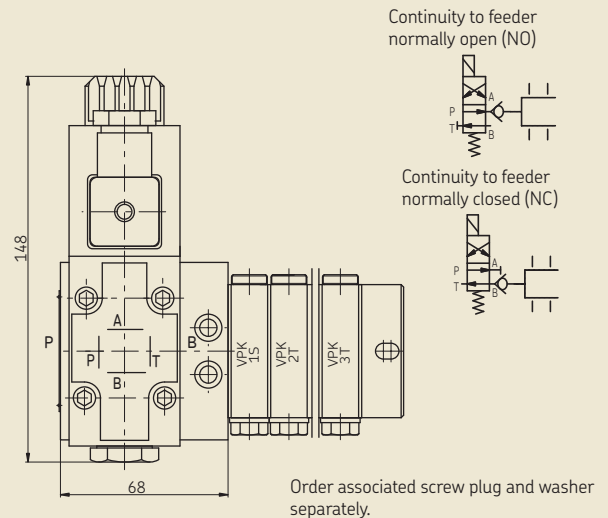

# Order code

## Sectional metering device of product series VPK\*)

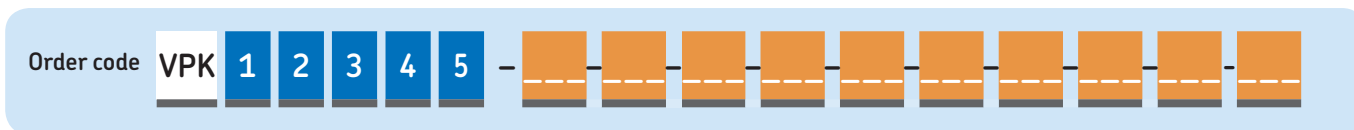

Feeder information

Choice 6/7/8: information on sections 1 to 10 as seen from inlet (min. 3 sections)

### Order example: VPKGYFXC-EMM-CMV-HSM-DMS-EMM (→ page 12)

#### 1 Thread type

Inlet- and outlet thread M10×1	M
Inlet- and outlet thread G <sup>1/8</sup>	G

#### 2 Selection of monitoring

none	X
Piston detector 2-pin, M12×1 plug	2
Piston detector 3-pin, M12×1 plug (wire breakage protection)	3
Cycle indicator, visual (plunger rod) <sup>1)</sup>	Y
Cycle indicator with holder and proximity switch M12×1 <sup>1)</sup>	S
Cycle indicator with holder for proximity switch M12×1 (without proximity switch) <sup>1)</sup>	G

<sup>1)</sup> The installation of the cycle indicator is **only** possible from feeder section 2T and 2S, respectively!  
Installation not recommended on first or last segment.

#### 3 Selection of installation position for monitor

X none		
left-hand side		right-hand side
U	10	V
S	9	T
Q	8	R
N	7	P
L	6	M
J	5	K
G	4	H
E	3	F
C	2	D
A	1	B

↑ Inlet

#### 4 Selection of attachments

	VPKM	VPKG
none	X	X
4/2-directional solenoid valve for oil	B	B
3/2-directional solenoid valve for oil	D	D
2/2-directional solenoid valve for oil	-	E

#### 5 Selection of inlet screw union

	VPKM	VPKG
none	X	X
Straight connector for tube ø6 mm, L <sup>1)</sup>	A	A
Straight connector for tube ø6 mm, tapered LL <sup>1)</sup>	B	-
Straight connector for tube ø8 mm, tapered LL <sup>1)</sup>	C	C
Straight connector for tube ø10 mm, tapered L <sup>1)</sup>	-	D
Straight connector, E02 for tube ø6 mm	E	E
Straight quick connector for tube ø6 mm	F	F
Straight quick connector for tube ø6 mm, tapered	G	G
Elbow for tube ø6 mm, tapered, L <sup>1)</sup>	H	H
Elbow for tube ø6 mm, tapered, LL <sup>1)</sup>	J	-
Elbow for tube ø8 mm, tapered, LL <sup>1)</sup>	K	K
Elbow quick connector, ø6 mm, tapered	L	L
Banjo fitting for tube ø6 mm, L <sup>1)</sup>	M	M
Banjo fitting for tube ø6 mm, LL <sup>1)</sup>	N	-
Banjo fitting quick connector for tube ø6 mm	P	P
Banjo fitting quick connector for tube ø6 mm, tapered	Q	-

LL-series = extra light version, L-series = light version, S-series = heavy duty version

<sup>1)</sup> Solderless pipe unions with cutting sleeve acc. to DIN 2353

\*) Online configurable under [skf-lubrication.partcommunity.com](http://skf-lubrication.partcommunity.com) (→ page 12).

# Order code

## Sectional metering device of product series VPK VPK

### 6 Selection of feeder sections

1st place section size <sup>1)</sup> (seen from the inlet)

Number of outlets 2 (Twin) Volume per cycle and outlet [cm <sup>3</sup> ]			Number of outlets 1 (Single) Volume per cycle and outlet [cm <sup>3</sup> ]		
Designation of sections			Designation of sections		
0.05	05T	<b>A</b>	0.10	05S	<b>B</b>
0.10	1T	<b>C</b>	0.20	1S	<b>D</b>
0.20	2T	<b>E</b>	0.40	2S	<b>F</b>
0.30	3T	<b>G</b>	0.60	3S	<b>H</b>

<sup>1)</sup> Smallest possible feeder size = 3 effective sections

### 7 2nd place outlet screw union, left-hand side; 8 3rd place outlet screw union, right-hand side

	VPKM	VPKG
No outlet port, screw plug	<b>S</b>	<b>S</b>
Outlet port without screw unions	<b>X</b>	<b>X</b>
Outlet port with 4 mm outlet screw union <sup>2)</sup> , tapered, LL	<b>A</b>	–
Outlet port with 4 mm outlet screw union <sup>2)</sup> , LL	–	<b>B</b>
Outlet port with 6 mm outlet screw union <sup>2)</sup> , tapered, LL	<b>C</b>	–
Outlet port with 6 mm outlet screw union <sup>2)</sup> , L	<b>D</b>	<b>D</b>
Outlet port with 8 mm outlet screw union <sup>2)</sup> , tapered, LL	<b>E</b>	<b>E</b>
Outlet port with 10 mm outlet screw union <sup>2)</sup> , tapered, L	–	<b>F</b>
Outlet port with 4 mm outlet screw union, EO2	<b>G</b>	<b>G</b>
Outlet port with 6 mm outlet screw union, EO2	<b>J</b>	<b>J</b>
ø4 mm quick connector	<b>K</b>	<b>K</b>
ø4 mm quick connector, tapered	<b>L</b>	–
ø6 mm quick connector	<b>M</b>	<b>M</b>
ø6 mm quick connector, tapered	<b>N</b>	<b>N</b>
Outlet port with 6 mm outlet screw union, with CV	<b>Q</b>	<b>Q</b>
6 mm quick connector-banjo fitting, with CV	<b>R</b>	–
Outlet port with 4 mm banjo fitting <sup>2)</sup> , LL	–	<b>W</b>
Outlet port with 6 mm banjo fitting <sup>2)</sup> , L	<b>1</b>	<b>1</b>
Outlet port with 6 mm banjo fitting <sup>2)</sup> , LL	<b>2</b>	–
4 mm quick connector-banjo fitting	<b>3</b>	<b>3</b>
4 mm quick connector-banjo fitting, tapered	<b>4</b>	–
6 mm quick connector-banjo fitting	<b>5</b>	<b>5</b>
6 mm quick connector-banjo fitting, tapered	<b>6</b>	–
Crossporting forwards (seen from the inlet)	↙ ↘	<b>V</b> <b>V</b>

<sup>2)</sup> Solderless pipe unions with cutting sleeve acc. to DIN 2353

### Selection of outlet ports (indicate selections 7 and 8!)

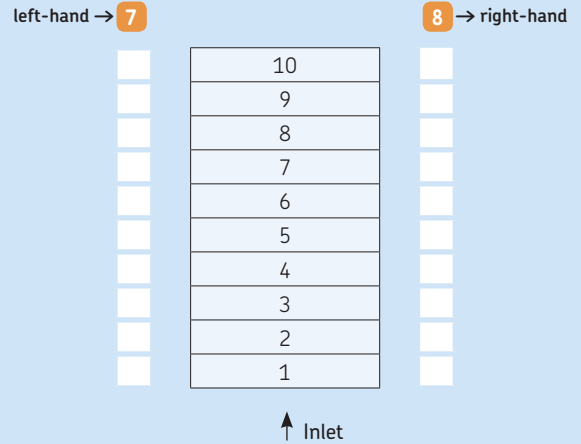

LL-series = extra light version, L-series = light version  
CV = Check valve

# Order example

## Sectional metering device of product series VPK

We recommend that you enter your desired sectional metering devices in Cadenas at [skf-lubrication.partcommunity.com](http://skf-lubrication.partcommunity.com) so that you can configure it quickly.

You will receive:

- A 3D drawing
- A 2D drawing
- A dimensioned drawing
- A complete order code
- A legend

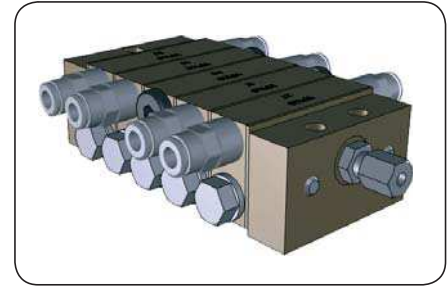

## Order code: VPKG YFXC-EMM-CMV-HSM-DMS-EMM

### Designation

Description	Clarification
Progressive sectional metering device	<b>VPK</b>
<b>1</b> Thread type	<b>G</b> (inlet and outlet thread G1/8)
Feeder size	5 sections
<b>2</b> Monitoring type	<b>Y</b> (cycle indicator, visual)
<b>3</b> Mounting position of the monitoring system	<b>F</b> (right-side, on 3rd section)
<b>4</b> Attachments	<b>X</b> (without)
<b>5</b> Inlet screw union	<b>C</b> (straight connector for tube $\varnothing$ 8mm, tapered, LL)
<b>1. Section</b>	
<b>6</b> Feeder section	<b>E</b> (2T – 0.20 cm <sup>3</sup> , 2 outlets)
<b>7</b> left side of section	<b>M</b> (straight quick connector for tube $\varnothing$ 6 mm)
<b>8</b> right side of section	<b>M</b> (straight quick connector for tube $\varnothing$ 6 mm)
<b>2. Section</b>	
<b>6</b> Feeder section	<b>C</b> (1T – 0.10 cm <sup>3</sup> , 2 outlets)
<b>7</b> left side of section	<b>M</b> (straight quick connector for tube $\varnothing$ 6 mm)
<b>8</b> right side of section	<b>V</b> (Crossporting nach vorne)
<b>3. Section</b>	
<b>6</b> Feeder section	<b>H</b> (3S – 0.60 cm <sup>3</sup> , 1 outlet)
<b>7</b> left side of section	<b>S</b> (no outlet port, screw plug)
<b>8</b> right side of section	<b>M</b> (straight quick connector for tube $\varnothing$ 6 mm)
<b>4. Section</b>	
<b>6</b> Feeder section	<b>D</b> (1S – 0.20 cm <sup>3</sup> , 1 outlet)
<b>7</b> left side of section	<b>M</b> (straight quick connector for tube $\varnothing$ 6 mm)
<b>8</b> right side of section	<b>S</b> (no outlet port, screw plug)
<b>5. Section</b>	
<b>6</b> Feeder section	<b>E</b> (2T – 0.20 cm <sup>3</sup> , 2 outlets)
<b>7</b> left side of section	<b>M</b> (straight quick connector for tube $\varnothing$ 6 mm)
<b>8</b> right side of section	<b>M</b> (straight quick connector for tube $\varnothing$ 6 mm)

### Order example diagram

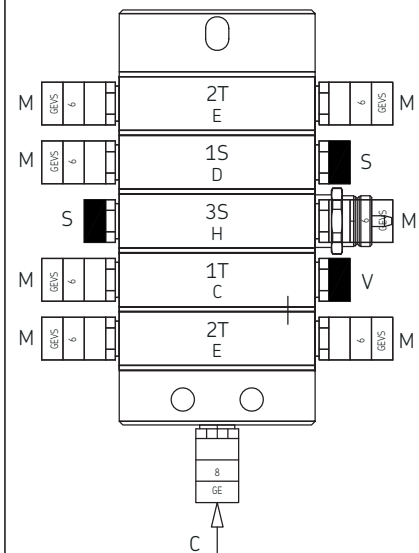

# Accessories

## Electrical plug-in connections

### Square connector

Order No.	Designation
179-990-033	Square connector per DIN EN 175301-803A, cable diameter 6–10 mm, 3-pin +PE, max. 1.5 mm <sup>2</sup>

### Circular connector M12x1

179-990-371	Straight circular connector (A), cable diameter –6 mm, 4-pin, max. 0.75 mm <sup>2</sup>
179-990-600	Straight circular connector (B), 4-pin with integrally extruded cable, 5 m, 4×0,25 mm <sup>2</sup>
179-990-372	Angled circular connector (C), cable diameter 4–6 mm, 4-pin, max. 0.75 mm <sup>2</sup>
179-990-601	Angled circular connector (D), with integrally extruded cable, 5 m, 4×0,25 mm <sup>2</sup>

→ Brochure 1-1730-EN

Square connector  
179-990-033



179-990-033

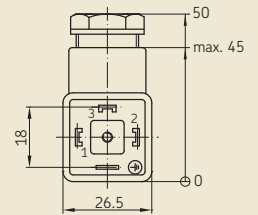

Circular connector M12x1

A B C D



# Exploded view

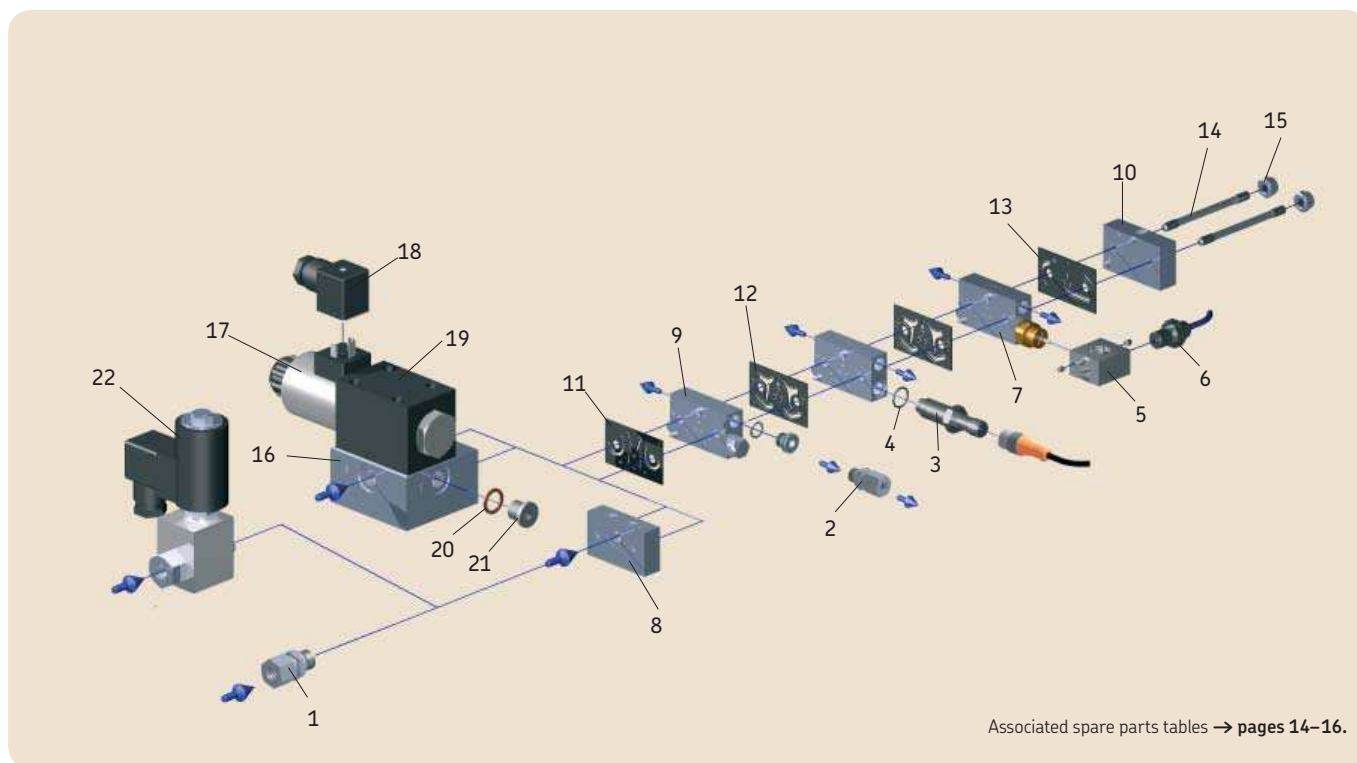

## Spare parts

Spare parts table 1

Inlet screw union		VPKG	VPKM
Item	Description	Order No.	Order No.
1	Straight connector for tube $\varnothing 6$ mm, L <sup>1)</sup>	406-403W	406-403
	Straight connector for tube $\varnothing 6$ mm, tapered LL <sup>1)</sup>	–	406-423
	Straight connector for tube $\varnothing 8$ mm, tapered LL <sup>1)</sup>	408-423W	441-008-511
	Straight connector for tube $\varnothing 10$ mm, tapered L <sup>1)</sup>	410-443W	–
	Straight connector, E02 for tube $\varnothing 6$ mm	471-006-192	471-006-311
	Straight quick connector for tube $\varnothing 6$ mm	406-423W-VS	406-004-VS
	Straight quick connector for tube $\varnothing 6$ mm, tapered	406-423W	451-006-518-VS
	Elbow for tube $\varnothing 6$ mm, tapered, L <sup>1)</sup>	406-405W	406-405
	Elbow for tube $\varnothing 6$ mm, tapered, LL <sup>1)</sup>	–	406-425
	Elbow for tube $\varnothing 8$ mm, tapered, LL <sup>1)</sup>	408-425W	408-425
	Elbow quick connector for tube $\varnothing 6$ mm, tapered	506-511-VS	506-510-VS
	Banjo fitting for tube $\varnothing 6$ mm, L <sup>1)</sup>	445-519-061	445-531-061
	Banjo fitting for tube $\varnothing 6$ mm, LL <sup>1)</sup>	–	445-531-062
	Quick connector-banjo fitting for tube $\varnothing 6$ mm	506-108-VS	506-140-VS
	Quick connector-banjo fitting for tube $\varnothing 6$ mm, tapered	–	455-531-068-VS

<sup>1)</sup> Solderless pipe unions with cutting sleeve acc. to DIN 2353

LL-series = extra-light version, L-series = light version

# Spare parts

Spare parts table 2

Outlet screw union			
Item	Description	VPKG Order No.	VPKM Order No.
2	Straight connector for tube $\varnothing 4$ mm <sup>1)</sup> , tapered, LL	–	404-403
	Straight connector for tube $\varnothing 4$ mm <sup>1)</sup> , LL	404-403W	–
	Straight connector for tube $\varnothing 6$ mm <sup>1)</sup> , tapered, LL	–	406-423
	Straight connector for tube $\varnothing 6$ mm <sup>1)</sup> , L	406-403W	406-403
	Straight connector for tube $\varnothing 8$ mm <sup>1)</sup> , tapered, LL	408-423W	441-008-511
	Straight connector for tube $\varnothing 10$ mm <sup>1)</sup> , tapered, L	410-443W	–
	Straight connector for tube $\varnothing 4$ mm, E02	471-004-191	471-004-311
	Straight connector for tube $\varnothing 6$ mm, E02	471-006-192	471-006-311
	Straight quick connector for tube $\varnothing 4$ mm	404-040-VS	404-006-VS
	Straight quick connector for tube $\varnothing 4$ mm, tapered	–	451-004-518-VS
	Straight quick connector for tube $\varnothing 6$ mm	456-004-VS	406-004-VS
	Straight quick connector for tube $\varnothing 6$ mm, tapered	406-423W-VS	451-006-518-VS
	$\varnothing 6$ mm outlet screw union, with CV	VPKG-RV	VPKM-RV-S4
	$\varnothing 6$ mm quick connector, with CV	–	VPKM-RV-VS
	$\varnothing 4$ mm banjo fitting <sup>3)</sup> , LL	445-519-041	–
	$\varnothing 6$ mm banjo fitting <sup>3)</sup> , L	445-519-061	445-531-061
	$\varnothing 6$ mm banjo fitting <sup>3)</sup> , LL	–	445-531-062
	$\varnothing 4$ mm quick connector–banjo fitting,	504-108-VS	504-102-VS
	$\varnothing 4$ mm quick connector–banjo fitting, tapered	–	455-531-048-VS
	$\varnothing 6$ mm quick connector–banjo fitting,	506-108-VS	506-140-VS
	$\varnothing 6$ mm quick connector–banjo fitting,, tapered	–	455-531-068-VS

<sup>1)</sup>Solderless pipe unions with cutting sleeve acc. to DIN 2353

LL-series = extra-light version, L-series = light version, CV = check valve

Spare parts table 3

Monitoring			
Item	Description	VPKG Order No.	VPKM Order No.
3	Piston detector, 2-pin	177-300-092	177-300-091
	Piston detector, 3-pin	177-300-095	177-300-095
4	Associated washer	WVN501-10x1.5	WVN501-10x1.5
5	Proximity switch housing	VPKM.13	VPKM.13
	Screws for housing fitting	DIN914-M4x6-45H	DIN914-M4x6-45H
6	NAMUR proximity switch	177-300-075	177-300-075

# Spare parts

Spare parts table 4

Feeder			
Item	Description	VPKG Order No.	VPKM Order No.
7	Feeder section 2T with cycle indicator right	VPKG-K-2T-ZY-R	VPKM-K-2T-ZY-R
	Feeder section 3T with cycle indicator right	VPKG-K-3T-ZY-R	VPKM-K-3T-ZY-R
	Feeder section 2T with cycle indicator left	VPKG-K-2T-ZY-L	VPKM-K-2T-ZY-L
	Feeder section 3T with cycle indicator left	VPKG-K-3T-ZY-L	VPKM-K-3T-ZY-L
	Feeder section 2S with cycle indicator right	VPKG-K-2S-ZY-R	VPKM-K-2S-ZY-R
	Feeder section 3S with cycle indicator right	VPKG-K-3S-ZY-R	VPKM-K-3S-ZY-R
	Feeder section 2S with cycle indicator left	VPKG-K-2S-ZY-L	VPKM-K-2S-ZY-L
	Feeder section 3S with cycle indicator left	VPKG-K-3S-ZY-L	VPKM-K-3S-ZY-L
8	Inlet section	VPKG-E	VPKM-E
9	Feeder section 05T	VPKG-K-05T-PS	VPKM-K-05T-PS
	Feeder section 1T	VPKG-K-1T-PS	VPKM-K-1T-PS
	Feeder section 2T	VPKG-K-2T-PS	VPKM-K-2T-PS
	Feeder section 3T	VPKG-K-3T-PS	VPKM-K-3T-PS
	Feeder section 05S	VPKG-K-05S-PS	VPKM-K-05S-PS
	Feeder section 1S	VPKG-K-1S-PS	VPKM-K-1S-PS
	Feeder section 2S	VPKG-K-2S-PS	VPKM-K-2S-PS
	Feeder section 3S	VPKG-K-3S-PS	VPKM-K-3S-PS
	Plug for T-section	917-006-101	917-006-101
10	End section	VPKM-A	VPKM-A
11	Inlet plate	VPKM.07	VPKM.07
12	Separator plate	VPKM.08	VPKM.08
13	End section	VPKM.09	VPKM.09
14	Tie rod for 3 feeder sections	DMAC947-11+C83	DMAC947-11+C83
	Tie rod for 4 feeder sections	DMAC947-11+ZY9	DMAC947-11+ZY9
	Tie rod for 5 feeder sections	DMAC947-11+B20	DMAC947-11+B20
	Tie rod for 6 feeder sections	DMAC947-11+F35	DMAC947-11+F35
	Tie rod for 7 feeder sections	DMAC947-11+C37	DMAC947-11+C37
	Tie rod for 8 feeder sections	VPKM.58	VPKM.58
	Tie rod for 9 feeder sections	VPKM.59	VPKM.59
	Tie rod for 10 feeder sections	VPKM.60	VPKM.60
15	Nut	DIN985-M6-8	DIN985-M6-8

Spare parts table 5

Attachments			
Item	Description	VPKG Order No.	VPKM Order No.
16	Start section for 4/2- and 3/2-directional solenoid valve	44-0711-2263	44-0711-2264
17	4/2-directional solenoid valve, 24 V DC, without item 20, 21	161-140-050+924	161-140-050+924
	3/2-directional solenoid valve, 24 V DC, without item 20, 21	161-140-050+924	161-140-050+924
18	Cable socket with protection circuit, 3m PUR cable and LED	179-990-416	179-990-416
19	Fixing bolt for directional solenoid valve	DIN912-M5×45-8.8	DIN912-M5×45-8.8
20	Washer	504-019	504-019
21	Screw plug	95-0018-0908	DIN908-M10×1-5.8
22	2/2-directional solenoid valve, 24 V DC	VPKG-VEN+924	-









**Further brochures:**

- 1-0107-6-EN Accessories for Progressive Systems*
- 1-1730-EN Electric Plug and Socket Connectors*
- 1-3010-EN Modular feeder product series PSG*
- 1-3016-EN Sectional metering device product series VP*
- 1-3028-EN Flow limiter SP/SMB8*
- 1-9201-EN Transport of Lubricants in Centralized Lubrication Systems*

**SKF Lubrication Systems Germany GmbH**

Hockenheim Plant  
2. Industriestrasse 4  
68766 Hockenheim  
Germany

Tel. +49 (0)6205 27-0  
Fax +49 (0)6205 27-101

**This brochure was presented to you by:**

© SKF is a registered trademark of the SKF Group.

© SKF Group 2016

The contents of this publication are the copyright of the publisher and may not be reproduced (even extracts) unless prior written permission is granted. Every care has been taken to ensure the accuracy of the information contained in this publication. However, no liability can be accepted for any loss or damage, whether direct, indirect or consequential, arising out of use of the information contained herein.

PUB LS/P2 16443 EN · January 2016 · 1-3015-EN

