

Directional Valves

for oil or grease

161-110-031



161-140-050



DCV5-4



Function

The directional valves listed on the following pages are used to control the flow of lubricants, e.g. to divide up a central lubrication system into a number of lube circuits (zoned actuation) or to switch between circulating and intermittently operated lube circuits.

Valves for a maximum pressure of up to about 45 bars can be used for single-line lubrication systems with piston distributors.

Valves for a pressure range of up to 300 or 500 bars are suitable for progressive systems.

Directional valves for oil or grease

Directional valves should be selected using the following criteria:

- 2, 3 or 4-way valve switching functions
- range of valve pressures
- flow rate of the valves
- lubricant for which the valve is to be used
- oils with a low or high effective viscosity,
- greases up to NLGI grade 2.

The valve data are listed in two tables, subdivided into:

- hydraulic and mechanical characteristics
- electrical characteristics.

See important product usage information on the back cover.

- *) Flow coefficient
 1) CC = characteristic curve
 2) BP = baseplate
 3) Max. 160 bars with connection T
 4) Remains in the last switching position selected

Hydraulic / mechanical characteristics

Order No	Valve function	Basic position	Type	Rated width [mm]	F _c *)	Connec- tion threads	Flow rate max. [l/min]	Max. pressure		Lubricants		Ambient temperature		Materials		Manual actuation	Fig.
								DC [bar]	AC [bar]	Oil [mm ² /s]	Grease NLGI 2 [mbar]	Lubricant temperature oil [°C]	Oil [°C]	Grease [°C]	Housing		
161-110-018	2/2	closed	seat valve	1.2	0.8	G 3/8	-	50	75	max. 21	-	-15 to +50	Al	NBR	yes	1	
161-110-031	2/2	closed	ball seat v.	-	-	G 1/4	cf. KL. 1)	500	-	4-1500	max. 700	-40 to +80	Al	-	yes	2	
161-110-032	2/2	closed	ball seat v.	-	-	G 1/4	cf. KL. 1)	500	-	4-1500	-	-40 to +80	Al	-	yes	2	
161-120-010	3/2	closed	seat valve	0.8	0.4	G 1/8	-	23	35	max. 21	-	-15 to +50	Al	NBR	yes	1	
161-120-018	3/2	closed	seat valve	0.8	0.4	G 1/8	-	23	35	max. 21	-	-	Al	FKM (FPM)	yes	1	
161-120-019	3/2	closed	seat valve	0.8	0.35	cf. GP 2)	-	23	35	max. 21	-	-15 to +50	Al	NBR	yes	3	
161-120-032 to 161-120-038	like 161-120-019 but 2-8 individual valves installed as valve manifold																
161-120-064	3/2	open C->B	ball seat v.	-	-	G 1/4	cf. KL. 1)	500	-	4-1500	max. 700	-40 to +80	Al	-	yes	5	
161-120-065	3/2	open C->B	ball seat v.	-	-	G 3/8	cf. KL. 1)	500	-	4-1500	max. 700	-40 to +80	Al	-	yes	5	
161-120-028	3/2	geschlossen	ball seat v.	-	-	G 1/4	5	320	-	4-800	-	-40 bi to s +80	Al	-	yes	6	
161-140-050	4/2	open P->A	sliding	-	cf. KL. 1)	cf. GP 2)	8 (NG 6)	320 3)	-	20-1000	-	-	Al	-	yes	8	
202-860	4/2	open P->A	sliding	-	cf. KL. 1)	cf. GP 2)	cf. KL. 1)	320 3)	-	10-500	-	-24 to +50	Al	-	yes	8	
DCV5-4	5/4	4)	sliding	1	-	M12x1.5	-	300	-	30-1500	max. 700	-25 to +80	Al	-	no	7	

1) Please indicate voltage, type of current and frequency when ordering

Electrical characteristics

Order No.	Available voltages ¹⁾	Rated current [A]	Rated power	Type of enclosure	ON time	Insulation class	Switching time ON [ms]	Switching time OFF [ms]	Electrical connections
161-110-018	Standard 24 V DC DC and AC	-	AC: 16 VA, 8 W DC: 10 W	IP 65 with plug	100 % ED	H 180	10-15	-	DIN EN 175301-803
161-110-031	24 V DC	0.67	16 W	IP 65 with plug	100 % ED at max. +35 °C	F	40	40	DIN EN 175301-803
161-110-032	230 V AC 115 V AC 50 or 60 Hz	0.10	20 W	IP 65 with plug	100 % ED at +20 °C	F	100	125	DIN EN 175301-803
161-120-010	DC and AC	-	10 W at 24 V DC 8 W at 220 V, 50 Hz	IP 65 with plug	100 % ED at +20 °C	H 180	10-15	-	DIN EN 175301-803
161-120-018	DC and AC	-	10 W at 24 V DC 8 W at 220 V, 50 Hz	IP 65 with plug	100 % ED	H 180	10-15	-	DIN EN 175301-803
161-120-019	DC and AC	-	AC: 10 W DC: 8 W	IP 65 with plug	100 % ED	H 180	10-15	-	DIN EN 175301-803
161-120-032 to 161-120-038	DC and AC	-	AC: 10 W DC: 8 W	IP 65 with plug	100 % ED	H 180	10-15	-	DIN EN 175301-803
161-120-028	DC and AC	2.0 at 12 V DC 1.0 at 24 V DC 0.14 at 220 V, 50/60 Hz	-	IP 65 with plug	DIN 43650-AF3	F	70	200	DIN EN 175301-803
161-120-064	12 V DC 24 V DC	1.70 at 12 V DC 0.83 at 24 V DC	20 W	IP 65 with plug	100 % ED at max. +35 °C	F	100	50	DIN EN 175301-803
161-120-065	12 V DC 24 V DC	1.70 at 12 V DC 0.83 at 24 V DC	20 W	IP 65 with plug	100 % ED at max. +35 °C	F	100	50	DIN EN 175301-803
161-140-050	DC and AC	1.33 at 24 V DC 0.17 at 220 V, 50 Hz	-	IP 65 with plug	100 % ED	-	-	-	DIN EN 175301-803
1202-860	DC and AC	-	30 W at 24 V DC 120 VA at 220 V, 50 Hz	IP 65 with plug	100 % ED	-	-	-	DIN EN 175301-803
DCV5-4	24 V DC ^{±2.5 %}	0.2 (start-up current 1.4)	5 W	IP 65	100 % ED	-	1000	-	M12x1

Fig. 1

161-110-018; 161-120-010; 161-120-018

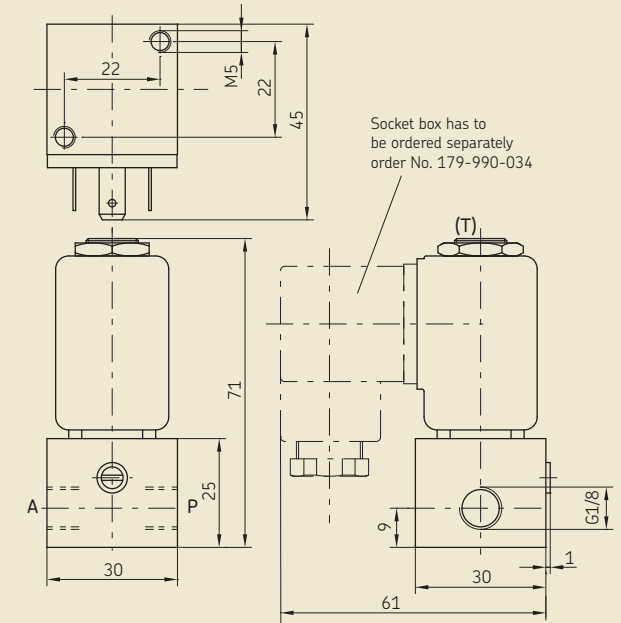

Graphical symbol for 161-110-018

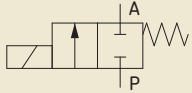

Graphical symbol for 161-120-010; 161-120-018

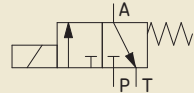

Fig. 3

161-120-019 (individual valve for manifolds 161-120-032 to -038)

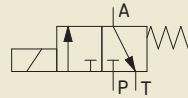
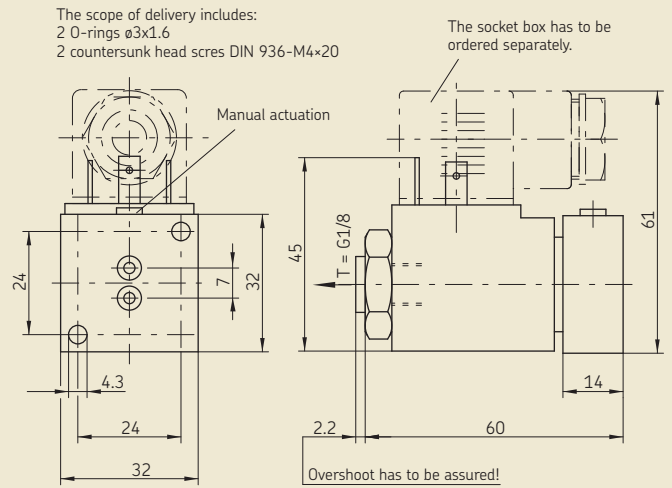
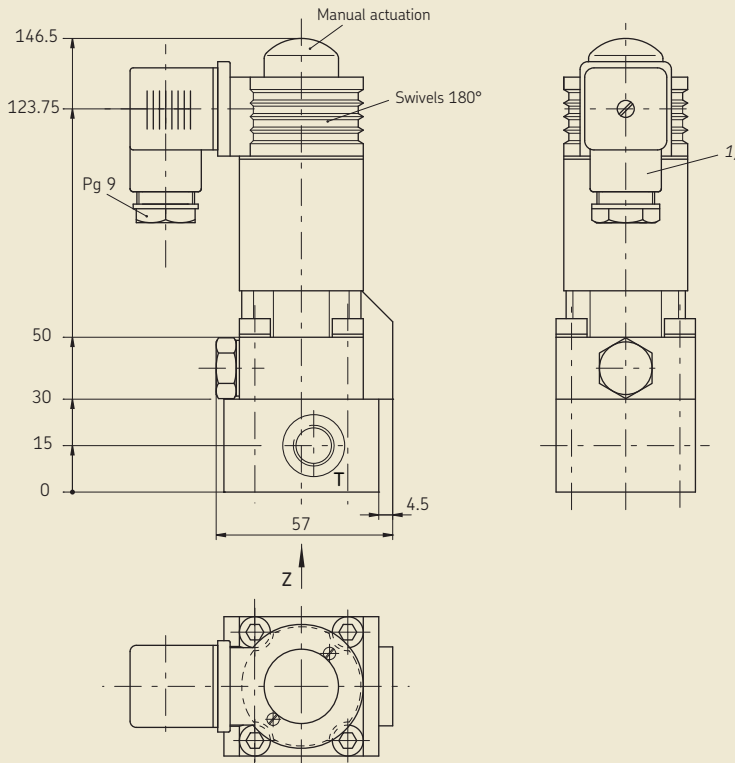

Fig. 2

161-110-031; 161-110-032



1) With 161-110-031 socket box; if there is a need for DIN EN 175301-803, it has to be ordered separately; e.g. 179-990-416 (with LED, protective circuit and integrally extruded 3 m long PUR cable).

Characteristic $\Delta p - Q$ (recommended value) with an oil viscosity - 60 mm²/s and 40 °C

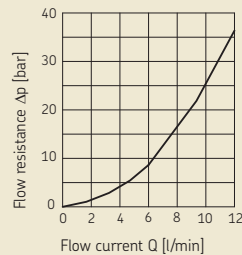

Graphical symbol for 161-110-031

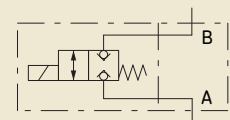

Graphical symbol for 161-110-032

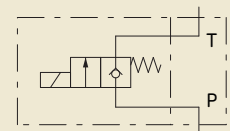

Fig. 6

161-120-032 to -038

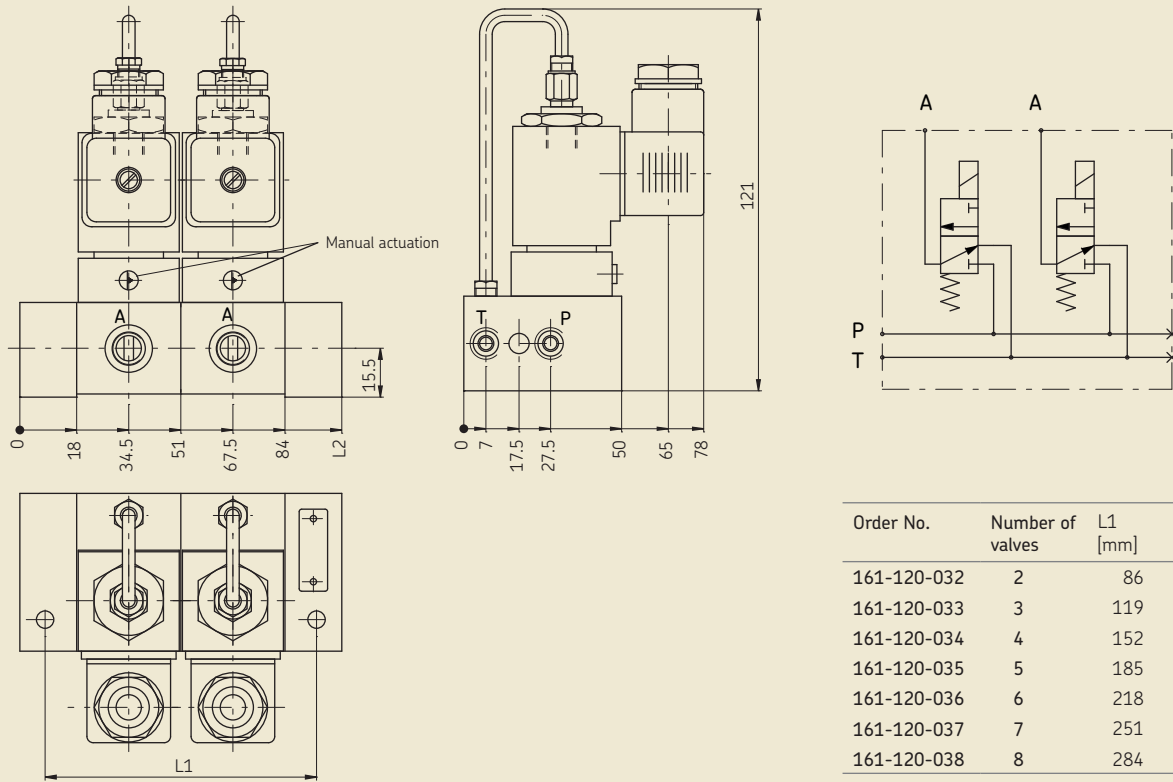

Fig.5

161-120-064; 161-120-065

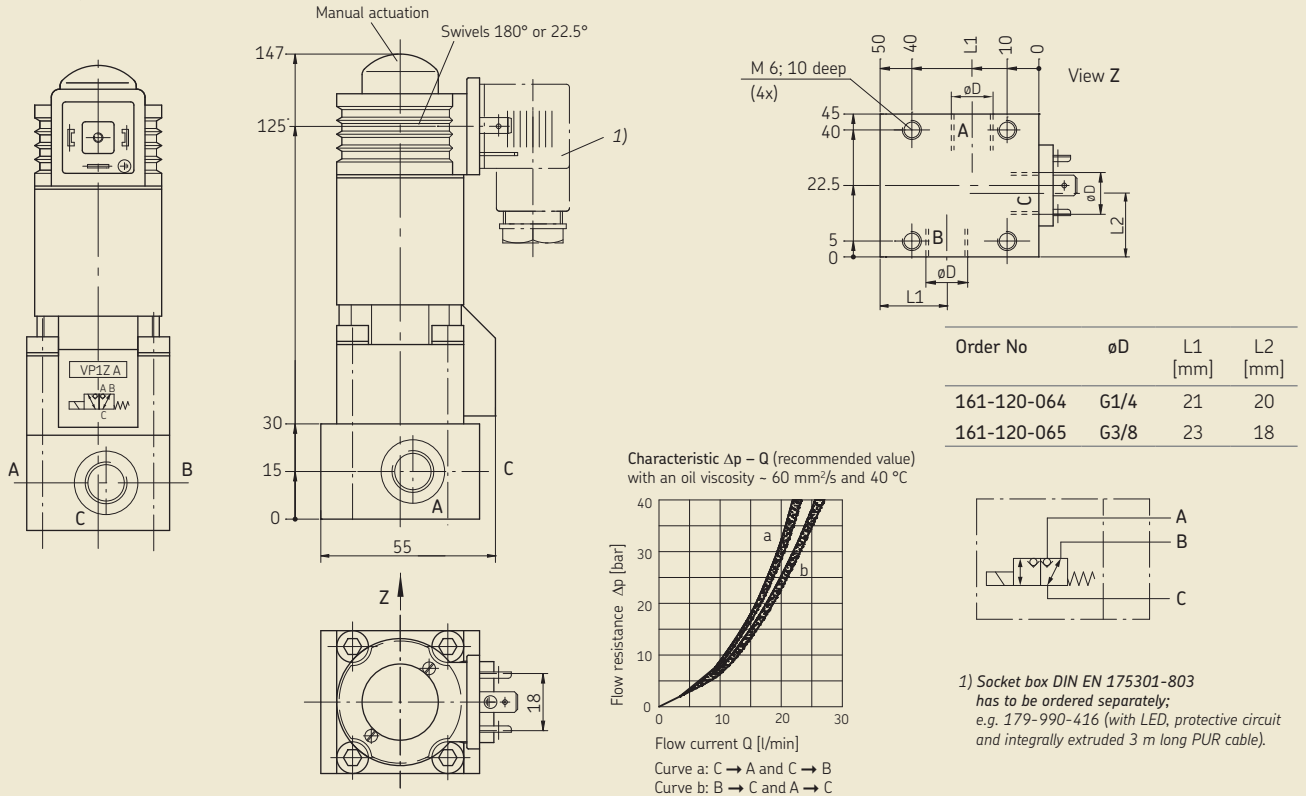

Fig. 6

161-120-028

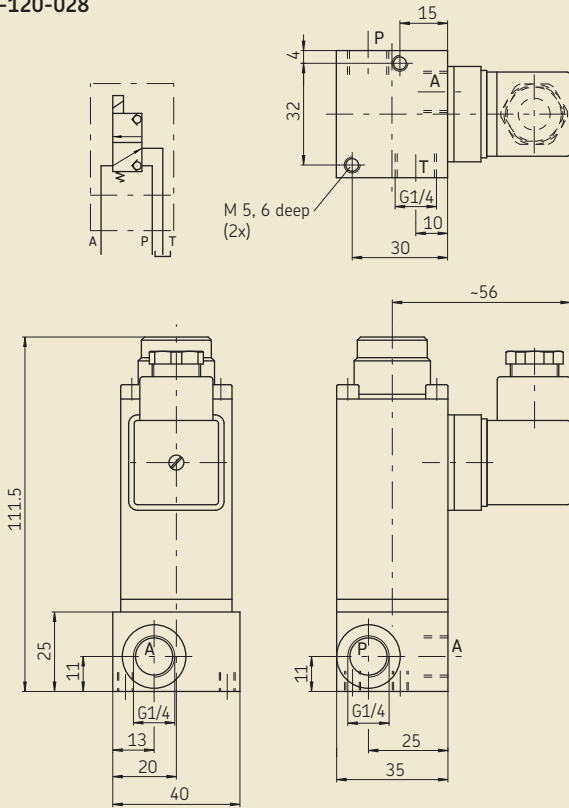
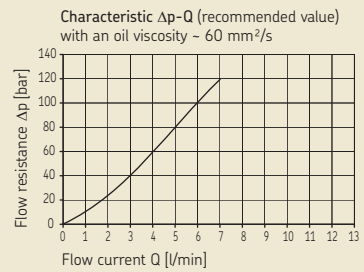
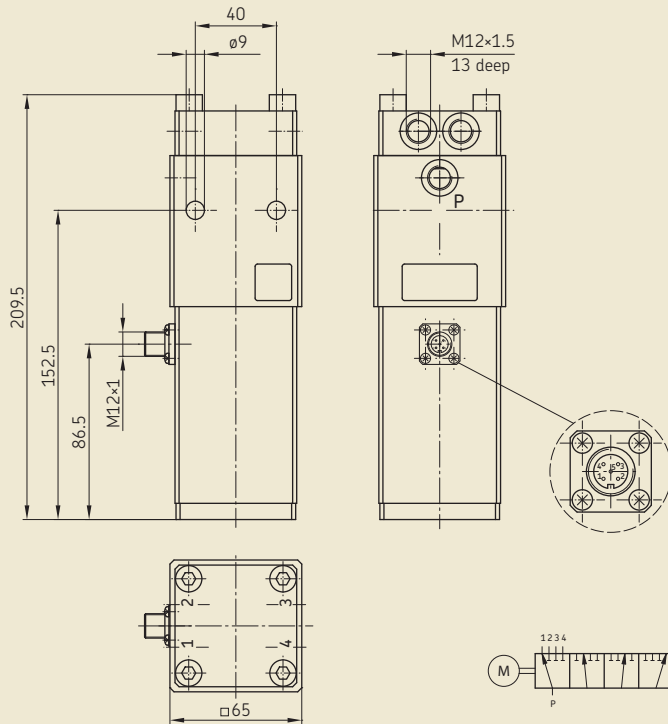

Fig. 7

DCV5-4



Pin	hydr. outlet	Circuit	Cable *) color
1	1	+24 V DC	brown
2	2	+24 V DC	white
3	3	+24 V DC	blue
4	4	+24 V DC	black
5	-	-(0 V DC)	grey

*) If a precut cable with socket is used.

161-140-050, 202-860

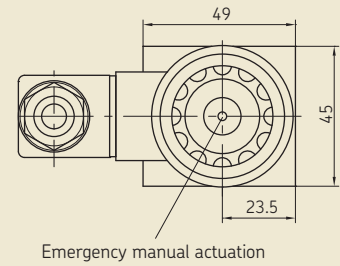
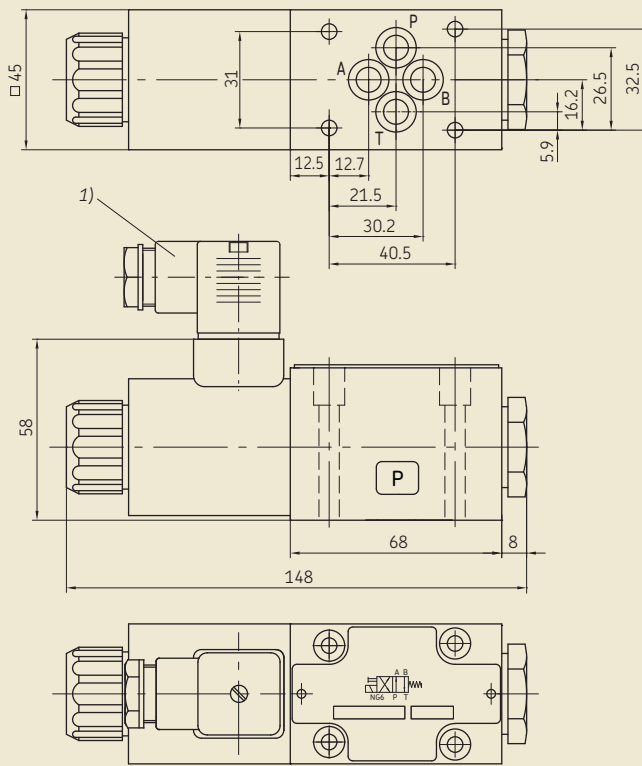

1) With 161-140-050 socket box; if there is a need for DIN EN 175301-803 it has to be ordered separately; e.g. 179-990-416 (with LED, protective circuit and integrally extruded 3 m long PUR cable)

Mounting plates for line connector

for directional valves 161-140-050, 202-860 (to be ordered separately)

892-530-020 bottom line connector

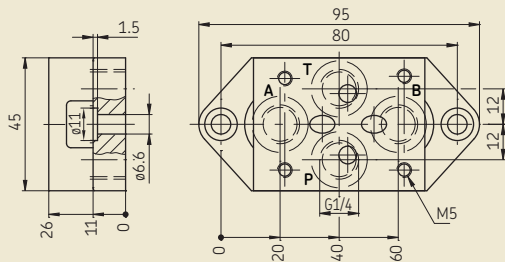

892-530-030 lateral line connector

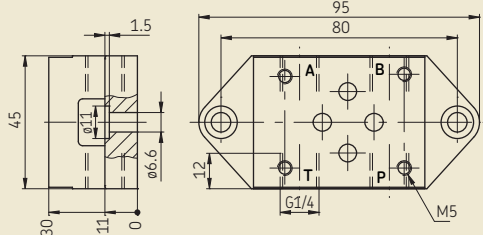

Attachment of directional valve to the respective mounting plate

4 cap screws, DIN912-M5x45-8.8
4 washers 650-050

The parts have to be ordered separately.

Connection fittings

Solderless tube union (at p max. to 50 bars)

Connecting piece for $\varnothing 6$ tubing : order No. 406-054
for $\varnothing 8$ tubing : order No. 301-020
for $\varnothing 10$ tubing : order No. 410-163

Washer: order No. 508-108

Tube union with cutting ring to DIN 2353
(at p max. greater than 50 bars)

Connecting piece for $\varnothing 8$ tubing : order No. 408-403W
for $\varnothing 10$ tubing : order No. 410-403W

Washer: order No. 508-108

Order No. 1-1703-EN

Subject to change without notice! (07/2014)

Important product usage information

All products from SKF may be used only for their intended purpose as described in this brochure and in any instructions. If operating instructions are supplied with the products, they must be read and followed.

Not all lubricants are suitable for use in centralized lubrication systems. SKF does offer an inspection service to test customer supplied lubricant to determine if it can be used in a centralized system. SKF lubrication systems or their components are not approved for use with gases, liquefied gases, pressurized gases in solution and fluids with a vapor pressure exceeding normal atmospheric pressure (1013 mbars) by more than 0.5 bar at their maximum permissible temperature.

Hazardous materials of any kind, especially the materials classified as hazardous by European Community Directive EC 67/548/EEC, Article 2, Par. 2, may only be used to fill SKF centralized lubrication systems and components and delivered and/or distributed with the same after consulting with and receiving written approval from SKF.

Further brochures

1-1730-EN Electric Plug-and-Socket Connectors

1-9201-EN Transport of Lubricants in Centralized Lubrication Systems

SKF Lubrication Systems Germany GmbH

Motzener Strasse 35/37 · 12277 Berlin · Germany

PF 970444 · 12704 Berlin · Germany

Tel. +49 (0)30 72002-0 · Fax +49 (0)30 72002-111

www.skf.com/lubrication

This brochure was presented by:

® SKF is a registered trademark of the SKF Group.

© SKF Group 2014

The contents of this publication are the copyright of the publisher and may not be reproduced (even extracts) unless prior written permission is granted. Every care has been taken to ensure the accuracy of the information contained in this publication but no liability can be accepted for any loss or damage whether direct, indirect or consequential arising out of the use of the information contained herein.

