

Multiline Pump Model 230

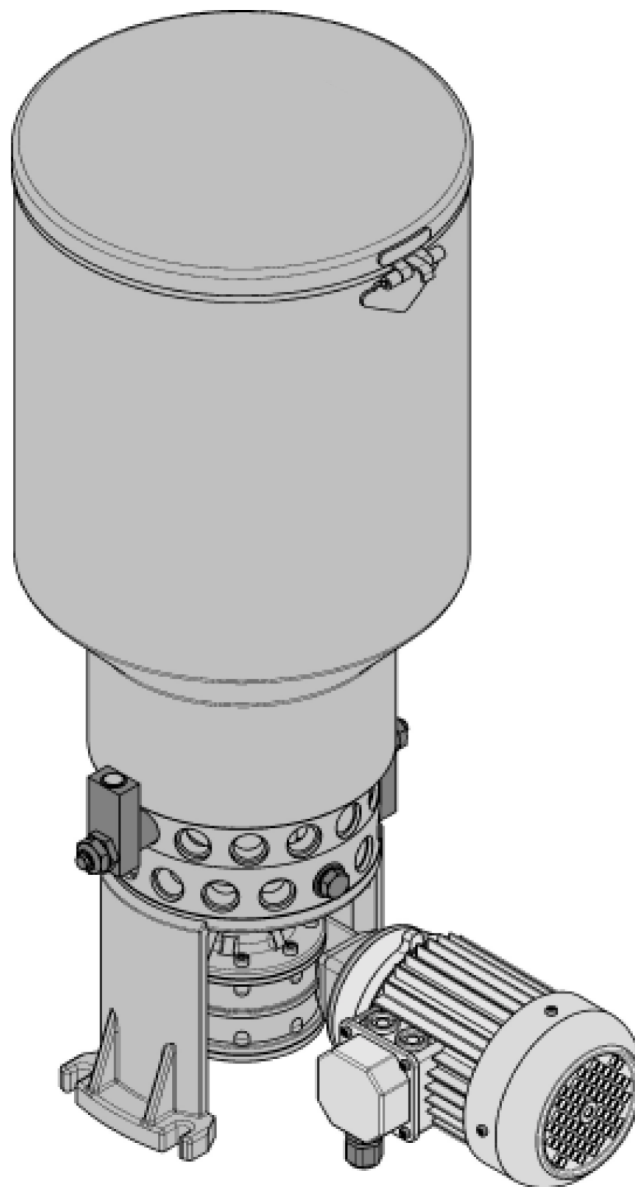

4484a03

Subject to change without notice

TABLE OF CONTENTS

	Page		Page
Safety Instructions	3	Putting into operation when fluid lubricants are dispensed	10
Appropriate use	4	Adjustment of the pump elements	10
Description	5	Maintenance and repair	11
Identification-chart	5	Troubleshooting	14
General	6	Component parts of pump 230	15
Operation	6	Annex : Dimensioned drawing	17
Operation of the low level control for grease reservoir "...XYBU"	7	Data sheets for motors	18
Technical data	7	Data sheets for ultra-sonic sensor	20
Erection and installation	8	Declaration of Conformity.....	22
Erection of the pump	8		
Electric Connection	8		
Operating Instructions	9		
Putting into operation	9		
Putting into operation when grease is dispensed	9		

Preface to the Owner`s Manual

• The Owner`s Manual

- is intended to familiarize the user with the pump/lubrication system and to be enable him to use it adequately
- must always be available on the site where the pump/ lubrication system is in operation
- must be read and used by all persons who are charged with working with the pump/lubrication system, e. g.

• **Operation**, including adjustment, troubleshooting during operation, elimination of production waste, maintenance, disposal of process materials

• **Maintenance** (inspection, repairs) and/or

• **Transport**

- Persons who **do not have a good command of the English language** must be informed by the user of the pump/lubrication system on the **contents of the Owner`s Manual, particularly the Safety Instructions, before they carry out the work.**

• The Operating Instructions

- contain important information for the safe, correct and economic operation of the pump/lubrication system. Their observance will help avoid hazards,
- reduce repair costs and downtime,
- increase the reliability and prolong the service life of the pump/lubrication system.
- must be supplemented by the respective national regulations concerning the prevention of accidents and protection of the environment.

Safety Instructions

- The Operating Instructions include general instructions which must be followed when a pump/lubricating unit is installed, operated or serviced. Therefore, it is absolutely necessary for the fitter and specialist/user to read the Operating Instructions before a unit is installed and put into operation. The Operating Instructions must always be available on the site where the machine/system is installed.
- All general safety instructions contained in this main chapter on safety must be observed as well as all special safety instructions given in other main chapters.

Hazard Marking in the Operating Instructions



Safety symbol acc. to
DIN 4844-W9

- The notes referring to safety contained in the Operating Instructions whose failure to observe them may result in personal injury are marked by the symbol above.

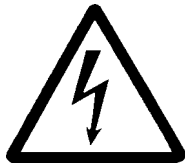

Safety symbol
acc.to DIN 4844-W8

- This symbol warns of an electrical current.

CAUTION

- If ignoring the safety note might result in machine damages and malfunction, the word **CAUTION** is added.

SKF Lubrication Systems Germany GmbH • Heinrich Hertz-Str. 2-8 D-69190 Walldorf Tel. +49(0) 6227 33-0 • Fax: +49 (0) 6227 33-259

- Warnings directly fixed to the machine must always be observed and must be kept in completely legible condition.

Staff Qualification and Training

- The staff responsible for operation, maintenance, inspection and installation must be adequately qualified for these jobs.
- The user must properly regulate the field of responsibility and supervision of the personnel.
- If the **personnel** is not in command of the necessary expertise, they must receive the appropriate **training and instructions**. If necessary, this can be done by the manufacturer/supplier on behalf of the machine user.
- Furthermore, the user must ensure that the contents of the Operating Instructions are fully understood by the personnel.

Hazards Resulting from Failure to Observe the Safety Instructions

- Failure to heed the safety warnings may result in damage to equipment and the environment and/or personal injury.
- Failure to observe the safety notes may result in the loss of all claims for damage.
- As an example, in the following we list some dangers which may result from failure to observe the warnings:
 - failure of machine/system to fulfill important functions
 - failure of specified methods for maintenance and repair
 - personal injury due to electrical, mechanical and chemical influences
 - danger to the environment due to leakage of harmful materials

Safety-Conscious Working

- Observe
- the safety instructions given in the Operating Instructions,
 - the prevailing national regulations for the prevention of accidents
 - any working and shop regulations and accident prevention measures of the user

Safety Instructions for the User/Operator

- If warm or cold machine parts present hazards, the customer must protect them against accidental contact.
- Do not remove protection devices for moving parts while the machine is in operation.
- Dispose of leakages of harmful materials so as to jeopardize neither persons nor the environment. The requirements of the law must be satisfied.
- Exclude danger caused by electrical current (for details refer to the applicable specifications of VDE and the local power supply companies).

Safety Instructions of maintenance, inspection and installation work

- The user must make sure that all maintenance, inspection and installation work is executed by authorized and qualified experts who have thoroughly read the Operating Instructions.
- On no account may work be done on the machine while the machine is in operation. Follow all instructions for shutting down the machine as described in the Operating Instructions.
- Reassemble all safety and protection devices immediately after completion of the cleaning procedure.
 - Decontaminate pumps and pump units delivering harmful materials.
 - Dispose of material harmful to the environment in accordance with the applicable official regulations.
 - Before putting the pump/pump unit into operation, ensure that all points given in the chapter "Putting into Operation" are fulfilled.

Unauthorized Modification and Spare Parts Production

- Alteration and modifications of the machine are only allowed if approved by the manufacturer. Original spare parts and accessories authorized by the manufacturer ensure safe operation.
- If other parts are used, the manufacturer may be released from its liability for the resulting consequences.

Inadmissible Operating Modes

- The operational safety of the supplied product is only granted if the product is operated according to the instructions given in the chapter "Appropriate use". The maximum ratings listed in the Technical Data must never be exceeded.
- Commissioning of the product (pump/pump unit) within the European Union is forbidden until it has been decided that the machine on which the product will be installed meets the requirements of the EU guidelines.

Appropriate Use

- The **pump model 230 is exclusively designed** for use in **centralized lubrication systems** for dispensing lubricants.
- On request, softeners for PVC and rubber can also be dispensed if they are mentioned on a special registration list.
- The maximum ratings mentioned in the Technical Data, particularly the maximum operating pressure of 350 bar, must not be exceeded.
- The multiline pump model 230 is a central lubrication pump with 1 to 30 pump elements and thus 1 to 30 outlets. The high pump operating pressure of 350 bar allows the pump to be used as a multiline pump for the direct supply of lubrication points, but also as a central lubrication pump in large-sized progressive systems.
- The great diversity of pump models allows the 230 multiline pump to be used for a wide range of applications, e.g.
 - machines in the steel industry (eccentric presses, forging machines)
 - machines in the conveying technology (cranes, drives for conveyors, conveyor worms)
 - machines in the construction industry (stone crushers), rubber and plastic mixers and rolling mills.
- **Any other use is not in accordance with the instructions and will result in the loss of claims for guarantee and liability.**

Description

Identification chart

The complete pump unit is defined by a type code on the nameplate.
 Examples of types codes:

Examples:

P230 - MG 100 - 30 XYBU -24K7 - 380-420, 440-480,500
P230 - F 490 - 10 XY N- 30 K7
P230 - MG 049 - 30 XY N- 18 K7 - 500

Basic type (housing assembly):

P230 : Housing assembly for all pump models

Drive assembly :

MG : Three-phase flanged motor
 0.25 kW for MG100/MG490, 0.37 kW for MG049
 The motor designation with extension e. g. for voltages, frequencies, explosion-proof design is added to the type code
 F : Free shaft end

100: Gear ratio $i = 100 : 1$
 490: $i = 490 : 1$
 049: $i = 49 : 1$

Reservoir assembly :

010: 10 l sheet metal reservoir
 030: 30l sheet metal reservoir

XY: Reservoir for grease and oil
 N : Reservoir without level control
 BU: Reservoir with low and high level control (ultrasonic sensor)

Note: The ultrasonic sensor is equipped with 2 switching points. If only one low level control is desired, the corresponding contacts must be connected. A 24 VDC supply voltage is required for the sensor.

The sensor corresponds to the requirements of EX zone 2 and EX zone 11 and may thus be used there.

Pump element assembly :

1 to 30 :Number of the pump elements
 K 6 oder K 7 :piston diameter (mm)

Extensions for the motor designation, e. g.:

380-420, 440-480: multi-range motor for network rated voltages
 380-420 V/50 Hz and 440-480 V/60 Hz in the case of a star connection
 500 : single-range motor for network rated voltages 500 V, 50 Hz
 000 : pump without motor, however with connecting flange

Subject to change without notice

General

- This Owner's Manual only refers to the high-pressure multiline pumps of the 230 series.
- It is intended for the personnel charged with the installation, operation and maintenance of the pump.

Applications

- If you require more information than given in this Owner's Manual, please contact: SKF Lubrication Systems Germany GmbH
Postfach 1263
D - 69183 Walldorf
Phone 06227/330
FAX 06227/33259
e-mail: Lubrication-germany@skf.com

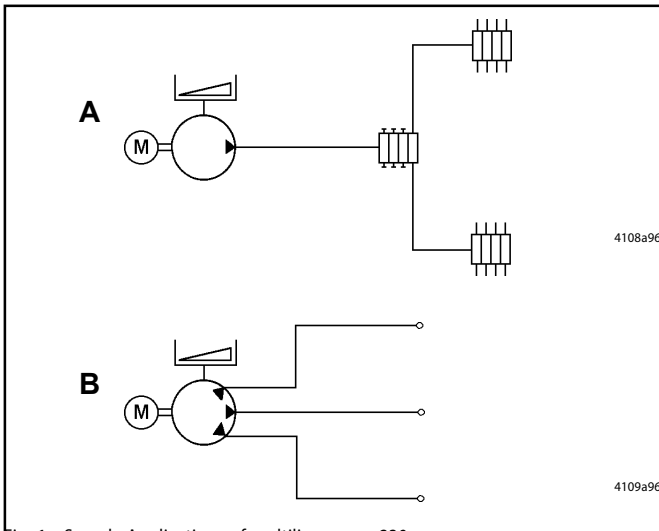

Fig. 1 - Sample Applications of multiline pump 230

- Pump model 230 used as a central lubrication pump for the supply of large-sized progressive systems (Refer to A, Fig. 1).
- Pump model 230 used as a multiline pump for the direct supply of individual lubrication points (Refer to B, Fig. 1)

Operation



Bild 2: Sectional drawing of pump model 230

- The pump essentially consists of the components shown in Fig. 2.
- The worm gear (6, Fig. 2) reduces the speed of the drive motor down to the speed of the eccentric shaft.
- The eccentric shaft (4) causes the piston lodged in the pump element (5) to move to and fro, with the result that the lubricant is sucked and dispensed to the outlet via a check valve.
- The eccentric shaft simultaneously drives the stirring paddle (3). The rotating movement of the stirring paddle makes sure that the lubricant is homogenized and directed into the suction boreholes of the pump element.

- | | |
|----------------------------------|---------------------|
| 1 - Housing | 4 - Eccentric shaft |
| 2 - Lubricant reservoir | 5 - Pump element |
| 3 - Stirring paddle with scraper | 6 - Worm gear motor |

4485a03

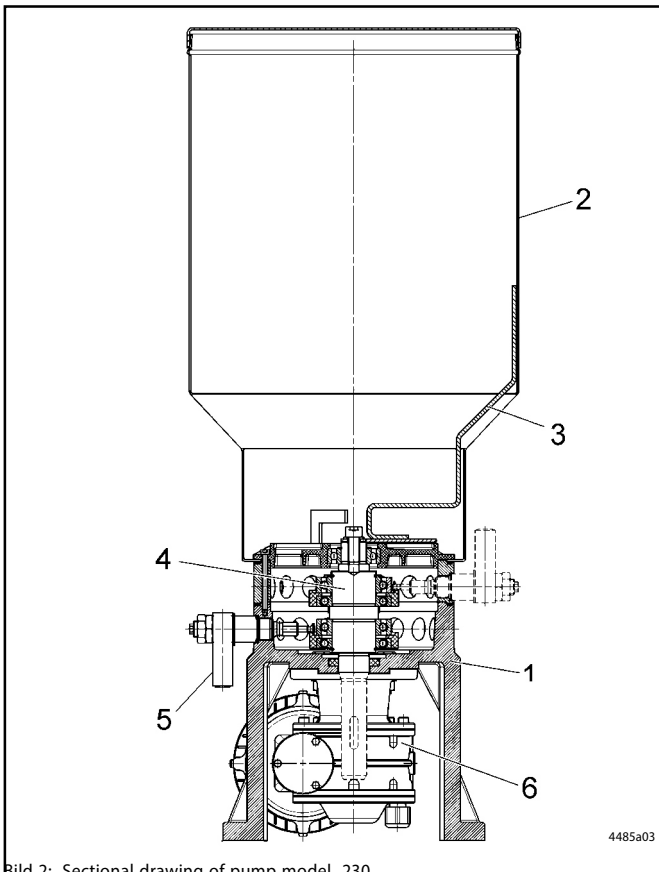
Subject to change without notice

Operation of the low level control for grease reservoirs “...XYBU”

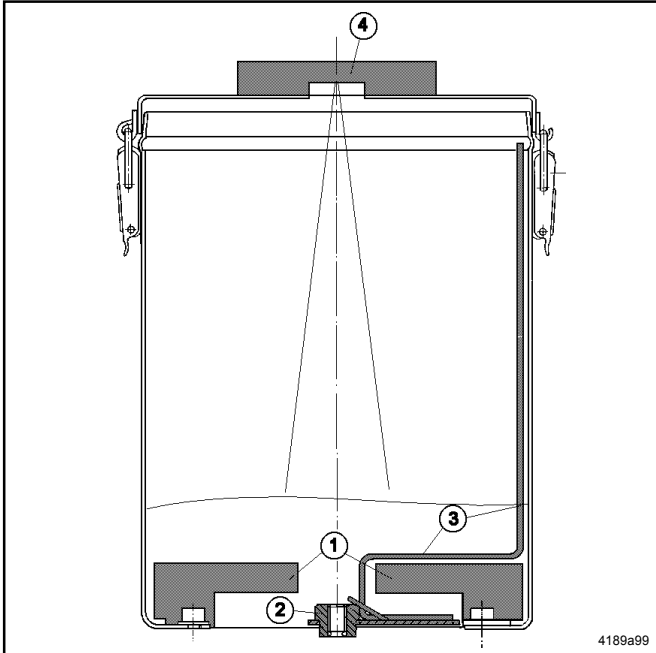

ATTENTION

Observe the direction of rotation of the pump drive (clockwise)

- The „empty“ signal (as well as the „full“ signal) are obtained via an ultrasonic sensor (4) installed in the middle of the reservoir lid.
- Two fixed paddles (1) are arranged 144° opposite the reservoir bottom. Thus, they form an obstruction to the grease pushed forward by the stirring paddle.
- The stirring paddle (2) turns below these fixed paddles, thus smoothing the grease level and producing a useful echo for the ultrasonic sensor.
- The low level signal takes place, as soon as the grease has dropped to a minimum.

Fig. 3 - Operation of the low level control (grease reservoirs “...XYBU”)

- 1 - Fixed paddle
- 2 - Stirring paddle
- 3 - Scraper
- 4 - Ultrasonic sensor

Technical Data

Number of outlets :.....1 to 30

Reservoir sizes :..... 10 oder 30 l
 deliverable on request :.....low level control or high level control

Note : If the pump is equipped with the maximum number of pump elements (i. e. 15) a filling connection cannot be fitted.

Threaded connection.....G1/4” i
 Filling connection (accessory):
 (part-no. 304-17571-1).....G1/4” i
 or
 (part-no. 304-17574-1).....G 1/2”i
 Maximum operating pressure350 bar
 (protection required by means of an adequate overpressure valve)

Kinds of drives:
 - with worm gearmotors
 - with worm gears and flange for three-phase a. c. motor-
 Ratios:.....100 :1

Note : in the case of 60Hz motors the lubricant output is increased by 20 %

Suitable lubricants :
 Lubricating grease up to NLGI-grade 2
 NLGI -grade 3 on request
 Mineral oils with a viscosity of 20 mm²/s

Lubricant output per piston stroke :
 for pump element with piston - Ø 6 mm:.....0.16 cm³
 for pump element with piston - Ø 7 mm:.....0.23 cm³
 Adjusting range :.....25 % bis 100 %

Subject to change without notice

Rated speed of drive :.....1370 rpm at 50 Hz
(see identification chart)
Min. speed of the stirring paddle.....2.5 rpm
(lower speeds on request, depending on the lubricant and
temperature)
Max. speed of the stirring paddle :.....35 rpm
(for fluid media)

*Note : in the case of lubricating grease of NLGI - grades 1 - 3,
the speed of the eccentric shaft must not exceed 20 rpm*

Weight of the pump:..... kg (with motor drive and 10 l
reservoir, without lubricant)
Weight of the pump element :0.6 kg
Sound level :≤ 70 dB (A)

Electric equipment

Three-phase flanged motor :.....technical data, on enclosed
motor data sheet (see annex)
Accessories (depending on the grade of equipment of the
pump)
Sensor for low and high level control (ultrasonic sensor)
for grease and oil (reservoir "XYBU") see page 20

Erection and Installation

Erection of pump

Requirements on the installation site :

- protect from dust and dirt
- safe against atmospheric influences (note the type of protection of the electric motor)
- enough space for opening the reservoir cover and executing the maintenance work (the required space depends on the pump size) even, solid and vibration-free installation site
- Depending on the pump design, it may be necessary to connect the drive. The direction of rotation of the pump and thus that of the driving shaft is clockwise.
- In the case of pumps with a free shaft end or an oscillating drive take care that the max. admissible speed of the drive or number of strokes is adhered to (see Technical Data).

Electric Connection

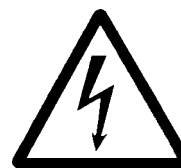

- All electric works should be carried out only by qualified personnel.

Electric connection of the drive motor:

- Terminal wiring diagram under the cover of the terminal box.
- Fuse protection in accordance with the national regulations in force; rated current consumption: see motor data sheet in annex

Electric connection of the level controls:

- Refer to the respective terminal diagrams in the annex and to the electrical wiring diagram

Commissioning

- Before putting the pump into operation fill the reservoir with lubricant via the reservoir lid or via a vacant pump element outlet.
- For filling via a vacant element, there are two possible filling connectors (see Technical Data). Remove an existing outlet closure plug (item 2, fig. 11) and screw in the filling connector.

Important: Pumps with an **integrated follower plate** (reservoir XLF and XBF) for low level or low and high level control are **not to be filled via the reservoir lid**. Filling must occur by means of a **vacant pump element outlet**.

Note: In some cases all pump element outlets may be occupied (with pump elements). In this case the above mentioned filling procedure is not possible. For this situation a filling hole, through the reservoir, between the follower plate and the housing (item 1, page 16) must be drilled and fitted with an appropriate connector. Take care that no particles enter the reservoir during the drilling.

CAUTION

- When filling the reservoir pay attention that no dirt or foreign particles enter the reservoir.
- Always refill the reservoir in time.
- Avoid contamination in the pump area.
- Before the pump is put into operation for the first time take care that all pump elements are adjusted on the zero output.



- Do not touch internal parts of the reservoir while the pump is in operation or connected to electrical source
- Risk of injury due to the stirring paddle.
- All system components which are connected downstream of the pump and on which the hydraulic pump pressure has an influence (e.g. progressive plunger metering device, tube lines, tube fittings, hoses) must be designed for maximum system pressure.
- Protect each pump element against overpressure by means of an adequate safety valve (max. opening pressure : 350 bar)

Putting the pump into operation when grease is dispensed

Pumps with low speed of the stirring < 10 rotations

- In the case of pumps with a slow drive (speed of the stirring paddle up to approx. 10 rpm) and in the case of all pumps which are operated by an oscillating drive fill so much oil for the first operation that the pump elements are entirely covered by oil. Then fill the grease which will be dispensed by the pump.
 - * Switch the pump on.
 - * Adjust the pump elements to the maximum output and wait until the grease emerges from all outlet ports.
 - * Adjust the required lubricant output at the pump elements.
 - * Switch the pump off.
 - * Connect the tube lines which are filled with grease to the outlet ports.
 - * The system is ready for operation.
- The lubricant output of each pump element can be altered at any time, even while the pump is in operation.

Pumps with speed of the stirring paddle > 10 rpm

- * Unscrew any closure plug from the housing.
- * Switch the pump on.
- The pump elements remain adjusted on the zero output until the grease emerges from the threaded hole in the housing. The time required for it varies between five minutes, in the case of pumps running very quickly, and five hours, in the case of pumps which operate extremely slowly. The ambient temperature and the consistency of the grease have a great influence on this time.
 - * Adjust the pump elements to the maximum output and wait until the grease emerges from all the outlet ports.
 - * Adjust the required lubricant output at the pump elements.
 - * Switch the pump off.

- * Screw the closure plug in again.
- * Connect the tube lines which are filled with grease to the outlet ports.
- The system is ready for operation.
- The lubricant output of each pump element can be altered at any time, even while the pump is in operation (refer to "Adjustment of the pump elements").

Putting the pump into operation when fluid lubricants are dispensed

- * Switch the pump on with the pump elements adjusted to the zero output.
- * After 5 minutes of pump operation adjust all the pump elements to the maximum output. As soon as the lubricant emerges from the outlet ports switch the pump off and connect the lubricant feed lines.
- * Adjust the pump elements to the required lubricant output.
- The system is ready for operation.
- The lubricant output of each pump element can be altered at any time, even while the pump is in operation (refer to "Adjustment of the pump elements").

Adjustment of the pump elements

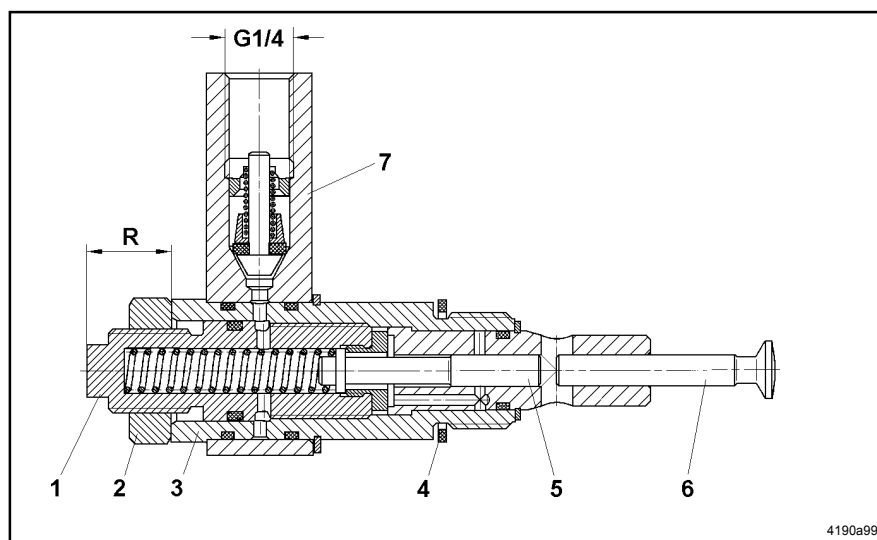

Fig. 4 - Sectional drawing of the pump element

- | | |
|-----------------------------|---------------------|
| 1 - Adjusting spindle SW 10 | 4 - Gasket |
| 2 - Counter nut (SW22) | 5 - Control piston |
| 3 - Pump body | 6 - Delivery piston |

7 - Outlet port with check valve

- * Loosen counter nut 2 (Fig. 4) and, using a second key, simultaneously keep threaded sleeve 3 from turning.
- * Turn adjusting spindle 1 with a wrench SW10:
clockwise = lower output
counter-clockwise = greater output

- The "R" dimension shown in Fig. 4 indicates the approximate lubricant output range:

R = 22.5 mm =	maximum output
R = 21.0 mm =	approx. ¾ output
R = 19.5 mm =	approx. ½ output
R = 18.0 mm =	approx. ¼ output

- * After the adjustment of the output, tighten counter nut 2 (Fig. 3). **Tightening torque: max. 12 Nm.**

Maintenance and Repair



Before undertaking any repair on the pump observe the following instructions:

- Switch the drive motor or mechanical drive off and protect it from inadvertent restart. Risk of injury by the stirring paddle.
- Loosen the pressure connection fittings on the pump element in order to decrease the pressure in the pump and in the system. Risk of injury due to lubricant splashing under high pressure.
- Repairs may only be carried out by qualified, skilled personnel using original SKF replacement parts.
- Provided that the pump dispenses only clean lubricant, it does not need any particular maintenance. Since the drive shaft and the pump elements are covered by the lubricant which is fed by the pump they are lubricated automatically.
- They are subject to a natural wear which depends on the operating time and operating pressure and must therefore be replaced.

Assembly and Disassembly of Pump Elements

Preliminary works:

- Switch the pump off and clean it on the outside.
- If the pump is filled with grease, the grease can remain in the pump. Fluid lubricants must be drained (unscrew the closure plug or the pump element)
- If the stirring paddle stays ahead of a pump element which must be disassembled, turn it until it is on the opposite side.

Attention: The delivery pistons cannot be changed!
When assembling or disassembling several pump elements take care that each delivery piston remains in the pump cylinder. The delivery pistons are adjusted in the pump cylinder with a clearance of only few micrometers.

Assembly

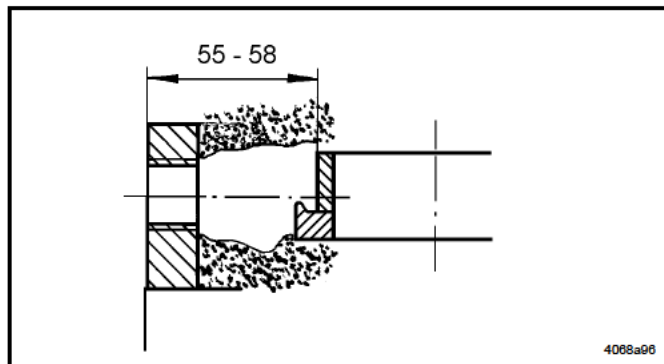

Fig. 5 - Digging a hole in the grease

- * Unscrew closure plug
- * Once the pump is filled with grease, dig a whole in the grease with a suitable object up to the eccentric ring (Fig.4).
- * Check whether the pump element is equipped with a gasket (see item. 4, Fig. 4).

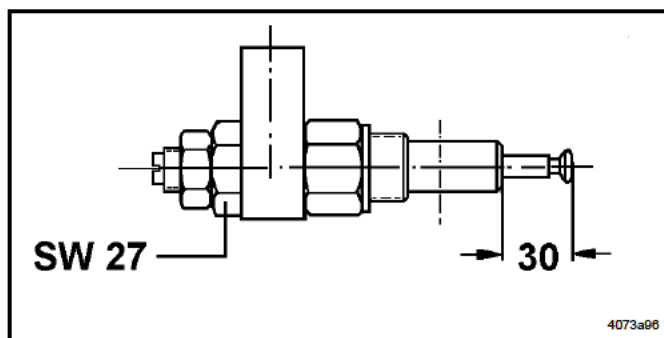

Fig. 6 - Removing the piston for the assembly of the pump elements

- Pull out the piston of the pump cylinder by about 30 mm.

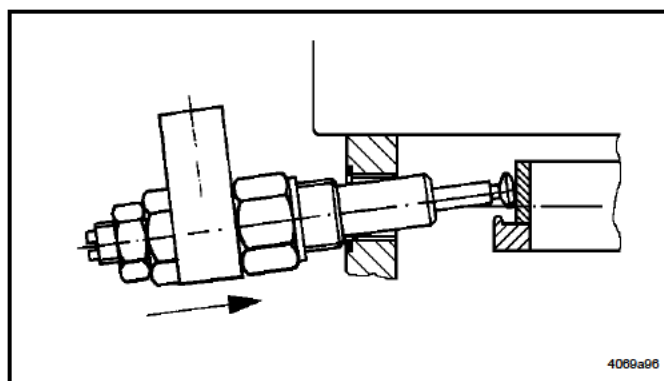

Fig. 7 - Inserting the pump element

- * Insert the pump element (Fig. 7) in such a way that is slightly directed upward in order to prevent the delivery piston from falling down because it is not fixed within the pump cylinder.

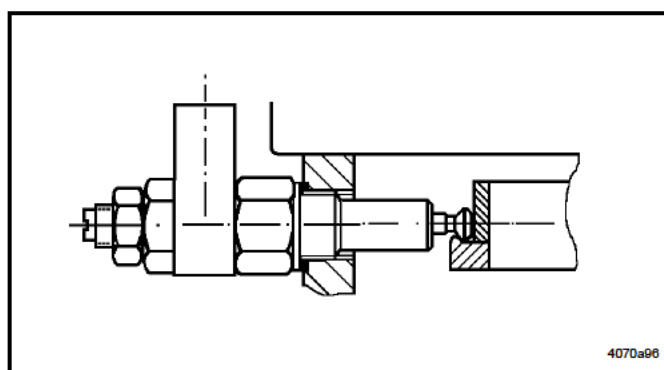

Fig. 8 - Pump element installed correctly

- * Put the pump element in horizontal position and at the same time hang the head of the delivery piston into the groove of the eccentric ring.

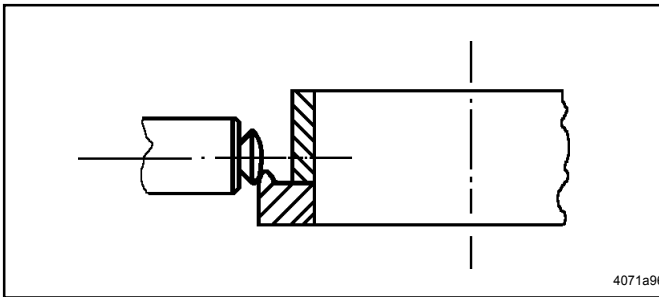

Fig. 9 - Incorrect assembly, lubricant output impossible

Attention : If the pump element is not installed correctly the lubricant cannot be dispensed and the pump may be damaged.

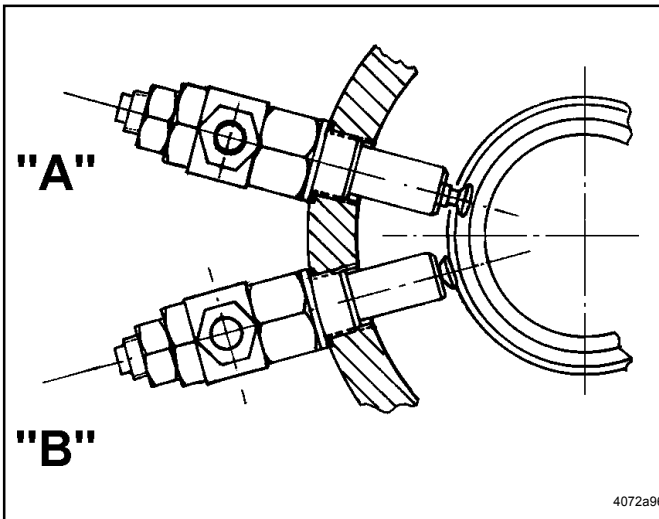

Fig. 8 - Correct and incorrect assembly

A - Correct assembly

B - Incorrect assembly

- First screw the pump element in by hand and then tighten it at the screwed plug 3 (Fig. 4) using a fork wrench SW27. Tightening torque: 30 - 35 Nm
- Pump elements which are installed must be set on the zero output adjusted in accordance with the instructions given in the chapter "Adjustment of the pump elements".
- If fluid lubricants are dispensed, fill them into the reservoir.
- Put the pump into operation as described on page 10.

Dissassembly of pump elements

- * Unscrew the tube line from the outlet port of the pump element.
- * Apply the fork wrench at the screwed plug (3, Fig. 4) of the pump element and carefully unscrew the pump element.
- * When disassembling or assembling (see Fig. 7) the pump element, direct it upwards in order to raise the delivery piston out of the groove of the eccentric ring.
- * Remove the pump element from the housing by means of the delivery piston.
- * Take care that the delivery piston does not stick in the grease.
- * Screw in a closure plug or a new pump element.

Maintenance of the ultrasonic sensor (reservoir "...XYBU")

- Take care that the surface of the sensor is clean.

Subject to change without notice

Troubleshooting

<ul style="list-style-type: none"> • Fault : The pump does not dispense the lubricant 	
<ul style="list-style-type: none"> • Cause : 	<ul style="list-style-type: none"> • Remedy :
<ul style="list-style-type: none"> • Reservoir empty 	<ul style="list-style-type: none"> • Fill up the reservoir with lubricant and vent the pump, if necessary. <i>Note: Depending on the ambient temperature and/or the lubricant it may be that the pump elements need about 10 minutes to be fully operative.</i>
<ul style="list-style-type: none"> • Air bubbles in the lubricant 	<ul style="list-style-type: none"> • Loosen the screwed outlet fitting at the pump element and let the pump operate until the lubricant emerges without air bubbles.
<ul style="list-style-type: none"> • Suction borehole of the pump element clogged 	<ul style="list-style-type: none"> • Disassemble the pump element and check whether foreign particles are lodged in the suction borehole. Remove them, if there are any.
<ul style="list-style-type: none"> • Check valve defective or clogged 	<ul style="list-style-type: none"> • Replace check valve.
<ul style="list-style-type: none"> • Pump piston worn 	<ul style="list-style-type: none"> • Replace pump element.
<ul style="list-style-type: none"> • Fault : Blockage in the progressive system connected downstream of the pump 	
<ul style="list-style-type: none"> • Cause: 	<ul style="list-style-type: none"> • Remedy:
<ul style="list-style-type: none"> • Bearing, lines or progressive metering device clogged The fault can be identified as follows: a) grease leaking from the safety valve b) the indicator pins fitted to the metering device pistons are not moving 	<ul style="list-style-type: none"> • Find out the cause of the blockage and eliminate it. If the blockage is due to a progressive metering device, disconnect all connecting lines one after another until the pump resumes delivery. The blockage is located in the tube line of the fitting which was the last to be unscrewed.

IMPORTANT : All the repairs which are beyond the knowledge of the user's personnel must be carried out by SKF experts. For this, return the defective pump to the repair department of the Walldorf works or call for a specialist who will carry out the repair on site.

Service address:

LINCOLN GmbH & Co. KG
Abt. Zentraler Kundendienst
Postfach 1263
D-69183 Walldorf

Component Parts of Pump Model 230-M 100-30XYBU..

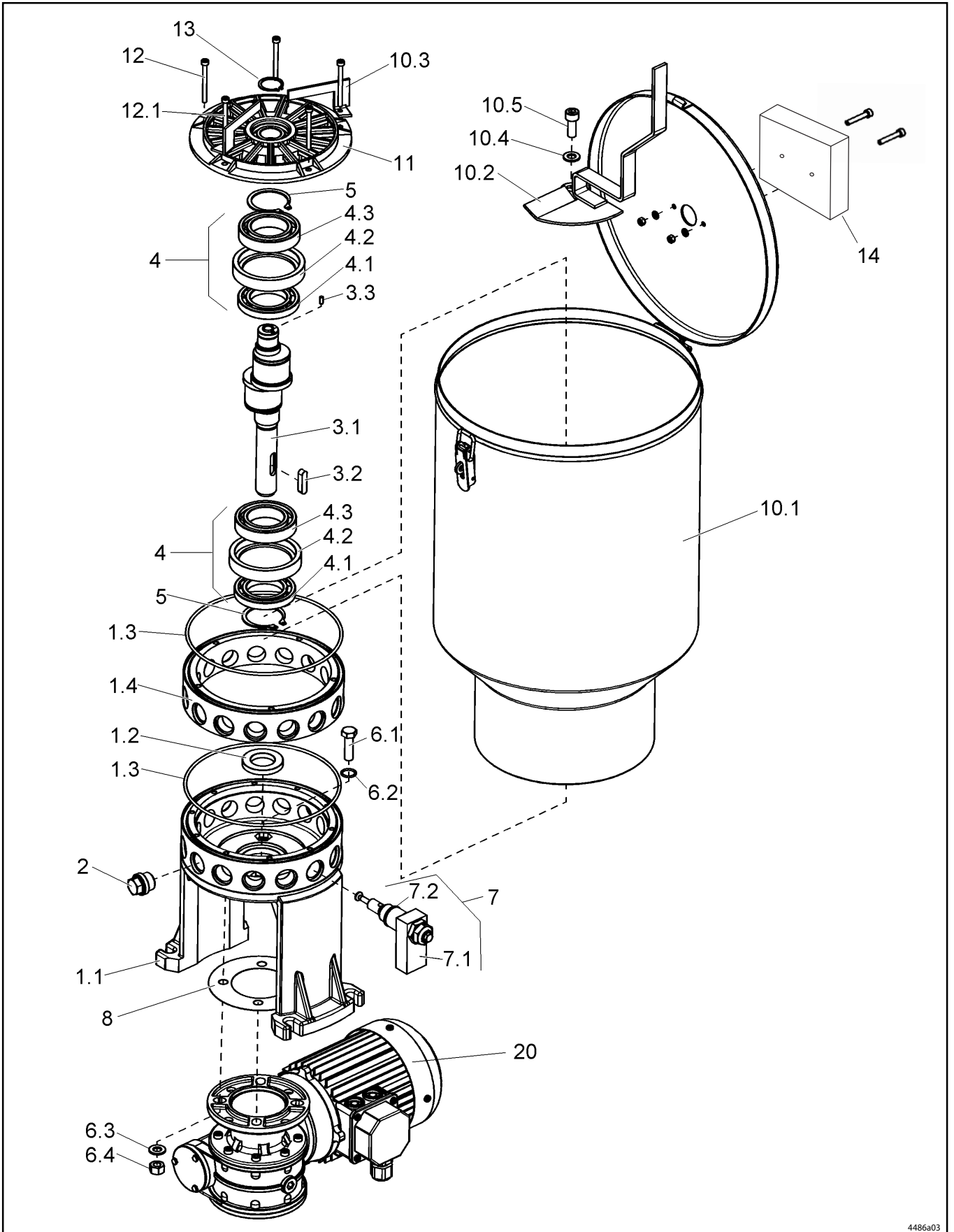

Subject to change without notice

Fig. 11 - Component parts of the pump model 230

4486a03

Item	Designation	Qty.	Part- no.	Item	Designation	Qty.	Part-no.
1.1	Housing	1	313-19924-1	10.5	Hexagon socket head screw M 10 x 25C	1	201-12027-6
1.2	Rotary shaft seal 30 x 50 x 7	1	220-12231-4	11	Intermediate bottom assy. for metal sheet reservoir	1	460-24568-1
1.3	O-ring 186 x 3.5	1	219-12226-8	12	Hexagon socket head screw M 5 x 55C	3	201-13067-7
1.4	Support ring	1	462-70162-1	12.1	Hexagon socket head screw M 5 x 60C	2	201-13067-6
2	Closure plug M 22 x 1.5		303-19285-1	13	Retaining ring A25 x 1.2	1	211-12164-6
3.1	Eccentric shaft	1	462-70161-1	14	Ultrasonic sensor (10l-reservoir)	1	664-85313-8
3.2	Feather key A 8 x 7 x 32	1	214-12176-3		Ultrasonic sensor (30l-reservoir)	1	664-85313-9
3.3	Dowel pin D 4 x 10	1	206-12498-3	20	Drive assy. with multirange motors 380 - 420/440-480 V		
4.1	Grooved ball bearing D45/75x10	2	250-14064-3		Gear 100:1, 0.25/0.29 kW	1	245-13965-2
4.2	Catch ring	2	460-24301-1		dto. with motor 290/500 V	1	245-13968-1
4.3	Grooved ball bearing D45/75x16	2	250-14064-4		0.25/0.29 kW		
4	Catch ring assy.	2	560-36903-3				
5	Retaining ring A45 x 1.75	2	211-12164-9				
6.1	Hexagon head screw M 10x35C	4	200-12008-6				
6.2	Sealing ring M 10	4	220-13653-7				
6.3	Washer A 10.5C	4	209-13077-2				
6.4	Hexagon nut M 10C	4	207-12136-1				
7	Pump element with piston Dia. 6 mm	-	600-25046-3				
	Pump element with piston Dia. 7 mm	-	600-25047-3				
7.1	Outlet port with check valve	-	560-32115-1				
7.2	Sealing ring ø 22.2 x ø 27 x 1,5	-	306-17813-1				
8	Sealing ring ø 70 x 126 x 0.5	1	306-19640-1				
10	10l - reservoir with cover	1	560-32012-1				
-	30l - reservoir with cover	1	560-32010-1				
10.2	Stirring paddle for 10l -reservoir	1	560-32128-1				
	Stirring paddle for 30 l reservoir	1	560-32129-1				
10.3	Fixed paddle	1	460-24566-1				
10.4	Washer A 10.5	1	209-13077-2				
	Set of packings	1	560-36919-2				
	consisting of item: 1.2, 1.3, 6.2, 8						
	Repair kit for pump element	1	560-36903-4				
	consisting of: 1 outlet port with check valve 2 O-ring 22 x 2 1 O-ring 15.3 x 24 1 gasket 22.7 x 27 x 1.5						

Dimensioned Drawing Pump P230 - MG100 - 30XYBU -

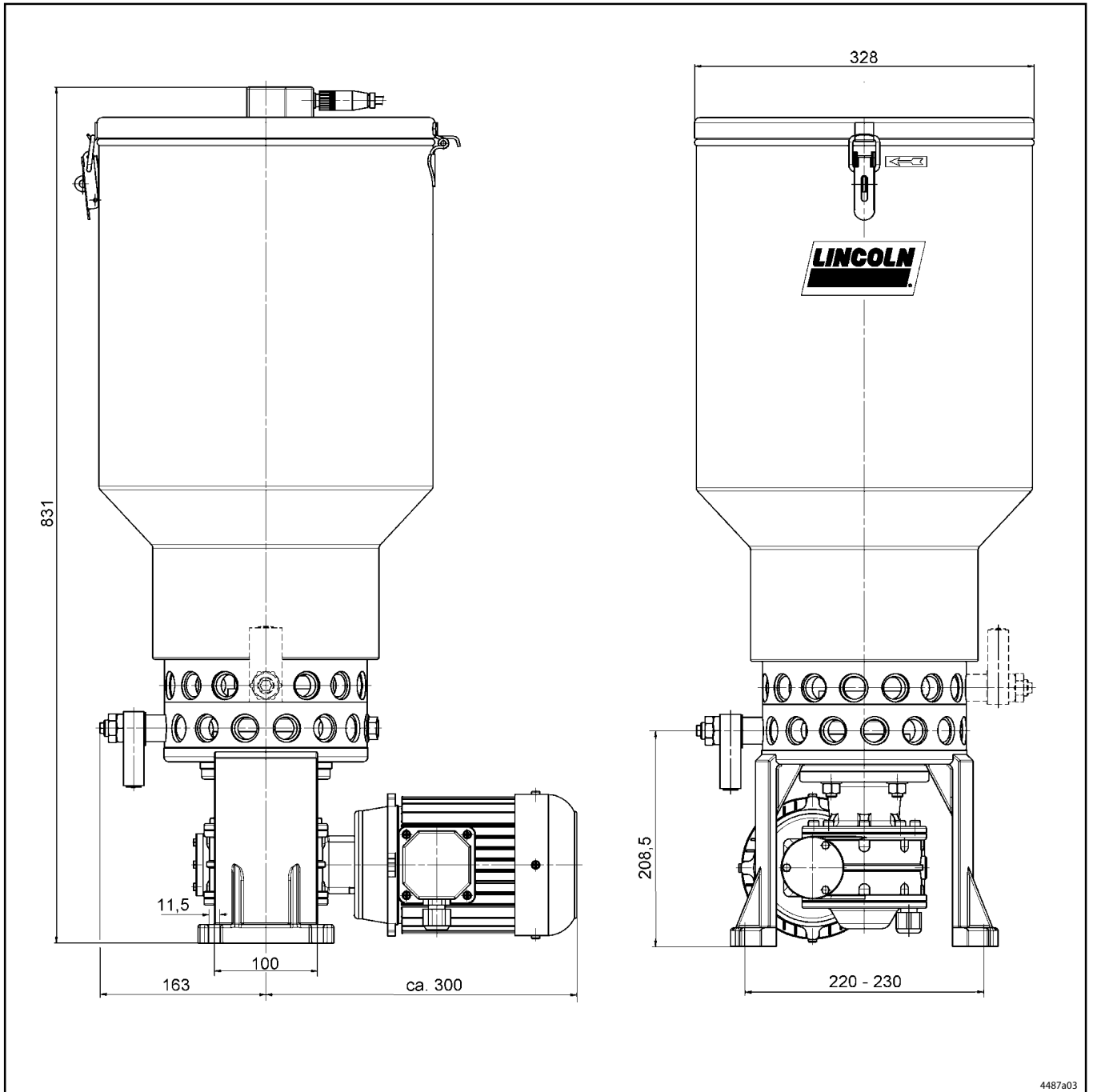

Fig. 16 - Dimensioned drawing for pump P230 - MG100- 30XYBU -

Subject to change without notice

Data Sheets

Motor Data Sheet

Standard-Motors for Pump Model 230/Three-Phase A. C. Asynchronous Motors

Pump model		230 - MG 049		230 - MG 100/490		Units
Motor type		T71B 4		DIC 63 L4		
Frequency	f	50	60	50	60	[Hz]
Nominal power	P	0.37	0.45	0,25	0,29	[kW]
Nominal speed	n	1370	1640	1334	1600	[min ⁻¹]
Rated torque	M	2.55	2.55	1.79	1.73	[Nm]
Nominal current	I _N	2.10	-----	2.07	-----	[A] at 220-240 V
		1.20	-----	1.20	-----	[A] at 380-420 V
		-----	2.10	-----	2.07	[A] at 380-275 V
		-----	1.20	-----	1.20	[A] at 440-480 V
Starting current/ ratio	I _A /I _N	3.5	3.5	3.6	3.6	[A]
Power factor	cos φ	0.74	0.74	0.77	0.77	
Efficiency	η	67	67	65	65	[%]
Frame size		71		71		
Type of construction		B 14		B 14		
Type of protection	IP	55		55		
Insulation class		F		F		
Weight		6.2		5.0		[kg]
Flange		∅ 105		∅ 105		[mm]
Shaft end		∅ 14x30		∅ 14x30		[mm]

The motors can be connected to the following networks :

220/380 V ± 5%, 50Hz
 230/400 V ± 10%, 50Hz
 240/415 V ± 5%, 50Hz
 254/440 V ± 5%, 60Hz
 265/460 V ± 5%, 60Hz
 480 V ± 5%, 60Hz

Other voltages and/or special designs available on request

Standard-Motors for Pump Model 230/Three-Phase A. C. Asynchronous Motors 290/500 V

Pump model		230 - MG 049	230 - MG 100/490	Units
Motor type			DIM 63 L4	
Frequency	f	50	50	[Hz]
Nominal power	P	0.37	0.25	[kW]
Nominal speed	n	1370	1336	[min ⁻¹]
Rated torque	M	2.55	1.79	[Nm]
Nominal current	I _N	0.98	1.66	[A] at 290 V
			0.96	[A] at 500 V
Starting current/ ratio	I _A /I _N	3.5	2.6	[A]
Power factor	cos φ	0.75	0.7	
Efficiency	η	67	43	[%]
Frame size		71	71	
Type of construction		B 14	B 14	
Type of protection	IP	55	55	
Insulation class		F	F	
Weight		6.2	5,0	[kg]
Flange		∅ 105	∅ 105	[mm]
Shaft end		∅ 14x30	∅ 14x30	[mm]

The motors can be connected to the following networks :

290/500 V ± 10%, 50Hz

Other voltages and/or special designs as well as other manufacturers available on request

CAUTION

For motors exposed to strong temperature changes, especially when operated in humid environments, we recommend providing condensate bores or installing an auxiliary heating system for stationary periods.

Data Sheet for Ultrasonic Sensor

Description of operation

This remote sensor is a solid state proximity type for 24 VDC which uses the echo delay-time method for distance sensing . It senses a sound-reflecting object which enters the sound cone from any direction. The objects to be sensed may be solid or liquid.

Installation

Figure I (dimensions in mm)

Any mounting position

Keep a free space around the sound cone of a distance "x" (x = 60 mm) from reflecting objects (figure I).

Connection

By means of cable socket (figure III) part no. 237-13442-2

Pin		
1	L+	DC 20 ... 30 V
2	S	Switching output "High level" (NO)
3	L-	Ground (GND)
4	S2	Switching input "Low level" (NC)

The connections are polarized, short-circuit proof and over-load-proof. In the case of electrical faults it is recommended to use shielded lines.

Operation

Switching range (figure IV)

a	Unusable blind zone
b	Sensing range
c	Overfill range
HV	Hysteresis „High level“
HL	Hysteresis „Low level“

The objects are sensed reliably in the set switching range within an opening angle of the sound cone of 5°. If the reflecting conditions are good, the objects can also be sensed outside the sound of cone. Keep the blind zone "a" free from objects. These would lead to undefined switching states. Take care that the surface of the transducer is clean.

Display:

Reservoir empty	H2 is lit
Filling level O.K.	H2 is non lit
Reservoir full	H1 is lit
Supply voltage	H3 is lit: green
Overfill signal	H3 is lit: red

Technical data

Ambient temperature:	-25...70°C
Sensing range:	50...500 mm*
Sensing distance „High level“	S1: 60 mm*
Sensing distance „Low level“	S2: depends on the reservoir size
Hysteresis „High level“	HV: 20 mm
Hysteresis „Low level“	HL: 50 mm
Switching point fault :	0.17% / K
* measured on the housing surface	

Supply

Rated operational voltage:	U _E	24 V DC
Operating voltage range:	U _B	20...30VDC
Admissible residual ripple:		10%
Open-circuit power consumption:		<60 mA

Switching output:

Rated normal current:	I _E	<200 mA
Voltage drop:	U _D	<3 V
Spurious switch-on pulse:		suppressed
Switching function „High level“:		NO contact switching on"plus"
„Low level“:		NC contact switching on"plus"

Typical values:

Availability delay:	250 ms
Reflection area:	10 x 10 mm ²
Ultrasonic frequency:	400 kHz
Switching frequency :	8 Hz
Resolution:	1 mm
Protection:	IP 65

Ultrasonic Sensor 664-853xx-x

Blind zone	0 - 65 mm
Scanning range limit	600 mm
Ultrasonic frequency	approx. 400 kHz
Switching frequency	3.7 Hz
Resolution	0.18 mm
Accuracy	±1 %
Repeatability	±0.15 %
Operating voltage U_B	9 - 30 V DC (polarized)
Residual ripple	±10 %
No-load supply current	≤ 60 mA
Type of connection	M12 x 1 plug; 5-pole
Response delay	272 ms
Readiness delay	< 300 ms
Type of protection following EN 60529	IP 65
Range of operating temperatures	-40 °C to + 70 °C

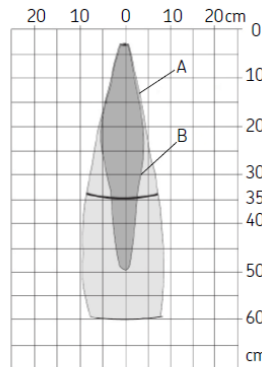

Detection zone in centimetres
The dark grey areas indicate the zone in which the standard reflector (pipe) is reliably detected. This is the typical operating range of the sensors. The light grey areas indicate the zone in which a big reflector – like, e.g. a plate – is still detected – provided it is optimally positioned to the sensor. Outside the light grey area an evaluation is not possible any more.
A = aligned plate, B = pipe

Switch points High-level indication D1 = 65 mm; low-level indication D2 corresponding to the reservoir size; pre-low-level indication D3 programmable on customer request

Compliance with standards	EN 60947-5-2
Current output 4 - 20 mA	RL ≤ 100 Ω at 9V ≤ UB ≤ 15 V RL ≤ 500 Ω at UB ≥ 15 V
Display elements	1 x LED yellow / 1 x LED green Switching output set / not set
Housing material	PBT, polyester, ultrasonic transducer, PUR, epoxy resin with glass contents
Switching output	3x pnp; UB-2V; Lmax = 3x 200 mA; selectable NO contact/ NC contact, short-circuit resistant



1	+ UB	brown
3	- UB	blue
4	D2	black
2	D1	white
5	D3/Com	grey

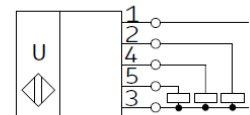

Dimensions

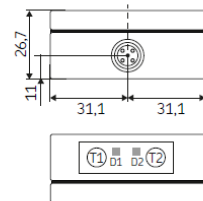
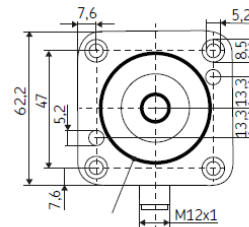

Regulatory notes



Electrical equipment according to directive 2014/30/EU
No safety component acc. To directive 2006/42/EC
Enclosure type 1 for use in industrial machinery NFPA 79 applications only

EC Declaration of Conformity

(in the sense of the Machinery Directive 2006/42/EC, Annex II Part 1 B)

The manufacturer

SKF Lubrication Systems Germany GmbH, Heinrich-Hertz-Str. 2-8, D - 69190 Walldorf

hereby declares that the incomplete machine

Designation: Pump for pumping lubricants

Type: **P230**

Item number: 662-xxxx- x

Year of construction: See type plate

satisfies all basic health & safety requirements of the Machinery Directive 2006/42/EC listed below

1.1.2 ○ **1.1.3** ○ **1.3.2** ○ **1.3.4** ○ **1.51** ○ **1.56** ○ **1.58** ○ **1.59** ○ **1.61** ○ **1.71** ○ **1.7.3** ○ **1.7.4**

when launched.

The special technical documents according to Annex VII Part B of this Directive have been compiled. We undertake to transmit, in response to a reasoned request by the national authorities, the special documents for this partly completed machine. The head of standardisation is the authorised agent for the technical documentation. For the address, please refer to the manufacturer.

The following standards were also applied in the respective applicable areas:

2011/65/EU RoHS II

2014/30/EU Electromagnetic Compatibility | Industry

Harmonised / other standards:

DIN EN ISO 12100	2011	DIN EN 60947-5-1	2010	DIN EN 61000-6-2	2006	DIN EN 61000-6-4	2011
DIN EN 809	2012	DIN EN 61131-2	2008	Amendment	2011	DIN EN 60947-5-1	2010
DIN EN 60204-1	2007	Amendment	2009	DIN EN 61000-6-3	2011		
Amendment	2010	DIN EN 60034-1	2011	Amendment	2012		
DIN EN 50581	2013	DIN EN 61000-6-1	2007				

The incomplete machine may only be commissioned once it has been established that the system into which the incomplete machine is to be installed satisfies all provisions of the Machinery Directive 2006/42/EC and all other applicable guidelines.



Walldorf
2016-02-15

Jürgen Kreutzkämper
Manager R&D Germany
SKF Lubrication Business Unit

Status of information:

02/2018

Manufacturer:

SKF Lubrication Systems Germany GmbH

Werk Walldorf

Heinrich Hertz-Str. 2-8

D-69190 Walldorf

Tel. +49(0) 6227 33-0

Fax: +49 (0) 6227 33-259

E-Mail: Lubrication-germany@skf.com

SKF