

OPERATION

This is a pilot operated spool type relief valve that relieves pressure from 1 to 2.

SPECIFICATIONS

Theoretical performance

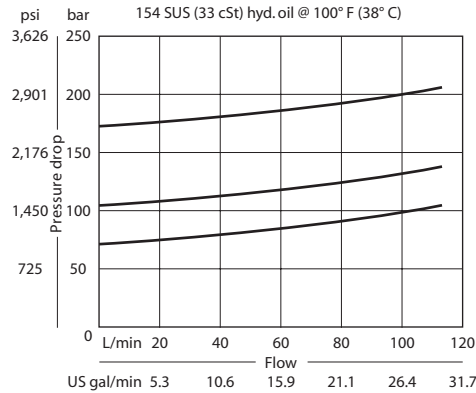

Schematic

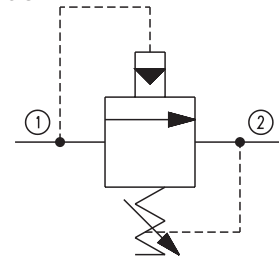

Specifications

Rated pressure	350 bar [5075 psi]
Rated flow	115 l/min [30 US gal/min]
Leakage	82 cm ³ /min [5 in ³ /min] @ 207 bar [3000 psi]
Weight	0.18 kg [0.40 lb]
Cavity	SDC10-2

DIMENSIONS

Cross-sectional view

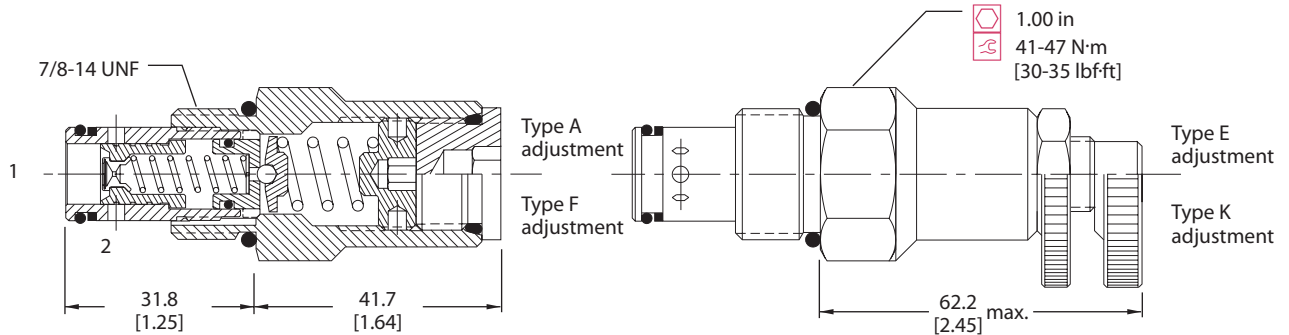

ORDERING INFORMATION

CP210 - 2 - B - 6S - A - C - 150

Seals
 B = Buna-N
 V = Viton

Seal kit
 120015
 120016

Housing and ports
 0 = No Housing
 DG3B = Al, 3/8 BSP
 DG4B = Al, 1/2 BSP
 6S = Al, #6 SAE
 8S = Al, #8 SAE
 Other housings available

Housing P/N
 No Housing
 SDC10-2-DG-3B
 SDC10-2-DG-4B
 CP10-2-6S
 CP10-2-8S

Adjustment option
 A = Internal
 E = External
 F = Tamper resistant
 K = Knob

Crack pressure
 Code x 10 = psi
 Example: 150 = 1500 psi

Pressure range

Code	bar	[psi]
A	14-69	[200-800]
Standard	28	[400]
B	14-103	[200-1500]
Standard	69	[1000]
C	28-207	[400-3000]
Standard	103	[1500]
D	28-345	[400-5000]
Standard	103	[1500]