

I&W

Electric Final Drive RD184

Datasheet
v2021.01

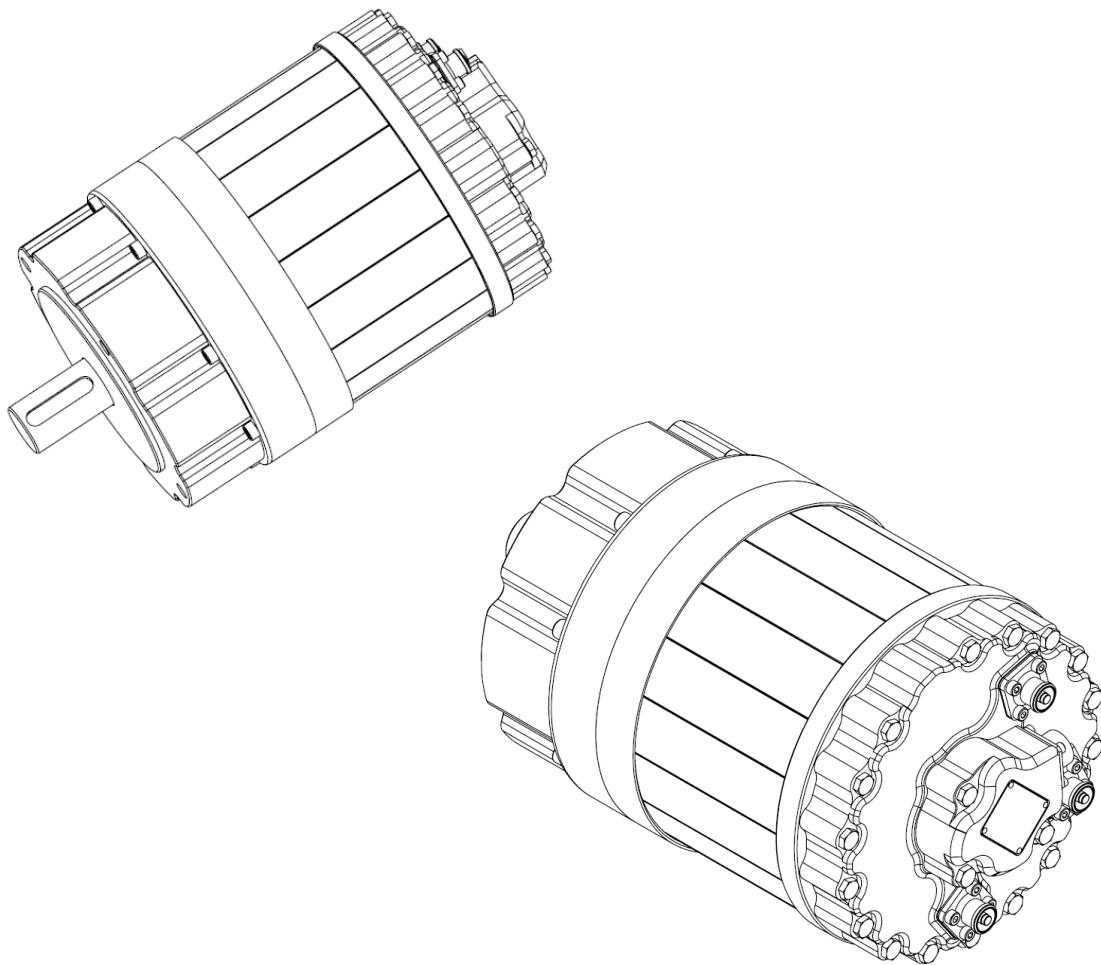

Performance Characteristics

General Information

Ambient Temperature	-20°C to 25°C*
Insulation Class EN 60034-1	F(155°C)
Enclosure Type DIN EN 60529	IP67 (Connector Mated) IP69k optional

*Derating for higher Temperatures

Drive

Engine Type	Permanentmagnet-Synchronous
Number of Poles	12
Reducer Ratio	5.7
Weight	34kg
Peak Torque (flange)	368 Nm
Peak Current (rms)	343 Arms
S2 Rated Speed	400 rpm
S2 60min. Torque (flange)	162 Nm
S2 60min. Current (rms)	162 Arms
Maximum Speed @ 48 V	496 1/min
Torque Constant @ motor shaft	0.19 Nm / Arms
Back EMF Constant (Line to Line, peak, rpm @ motor shaft)	16.5 V / 1000 min ⁻¹
Electrical Resistance (Rs) @ 25°C	2.5 mΩ
Electrical Inductance @ 1kHz (Lq/Ld)	50 mH/43 mH

Performance

- ■ ■ Speed limit at DC-link Voltage without field weakening

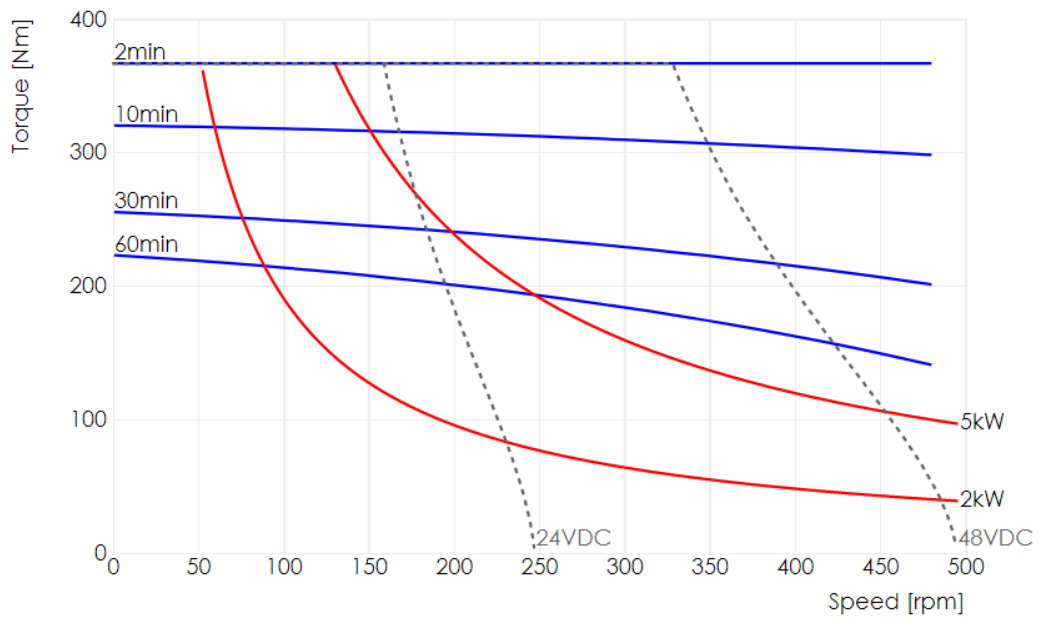

Feedback

Temperature Sensor

Sensor-Type	PT 1000
-------------	---------

Angle Sensor

Sensor-Type	SIN/COS-Encoder
Power Supply (V_{dd})	5V +/-5%
Power Consumption	20mA
Output Amplitude	1.1 +/-0.2V _{pp}
Output Offset	$V_{dd}/2$ +/- 5mV
Internal serial Impedance	720Ω

Dimensions and Load

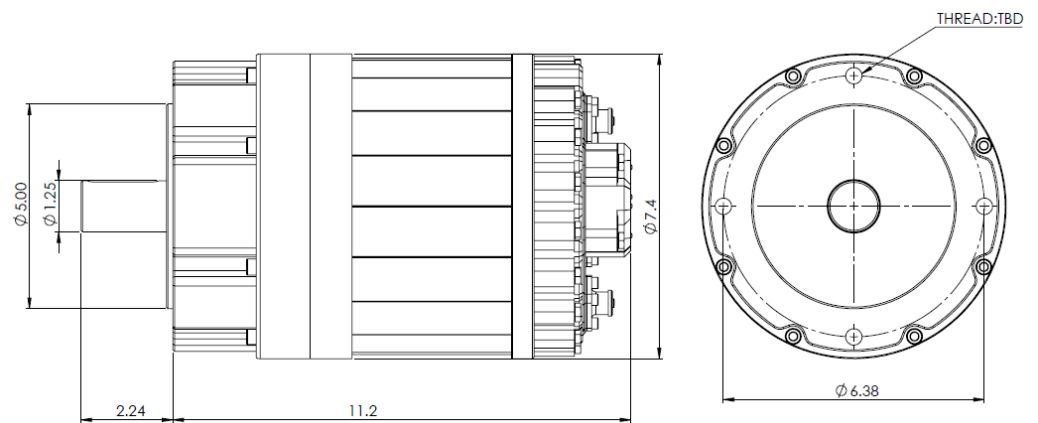

Bearing

F_{DYN}	43kN
F_{STAT}	57kN

Connections

Power connections

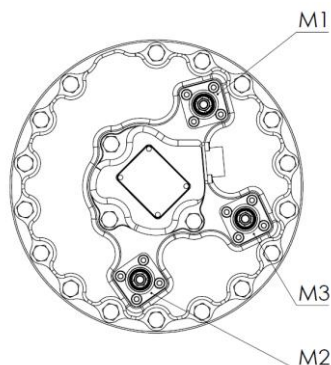

Connector	AMPHENOL SURLOCK PLUS
Part number	SLPPA25BSO
Included	No

Cable-size	25mm ²
Included	No

Signal Connections (SIN/COS)

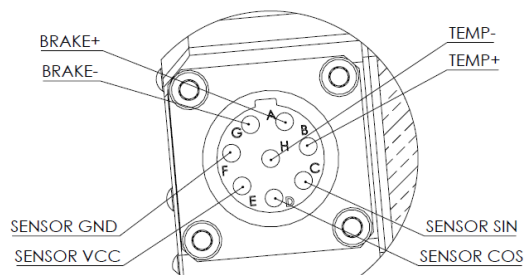

Mating Connector	Amphenol Ecomate RM
Connector	RT06128SNH
Backshell	RT0L-12CG-S1 (6-10.5mm cable)
Socket (8x)	SS20M1F (0.34-0.5 mm ²)
Included	No