

OPERATION

The VCB06-EN is a cartridge style, 6-size metric counterbalance valve with hydraulic vent. This valve is 3-ported, externally piloted and low leakage. The check section allows free flow from the directional valve (port 2) to the load (port 3). Reverse flow is blocked until pilot pressure is applied at port 1. When the load pressure at port 3 rises above the pressure setting, the integral relief valve is activated and pressure is relieved from port 3 to port 2.

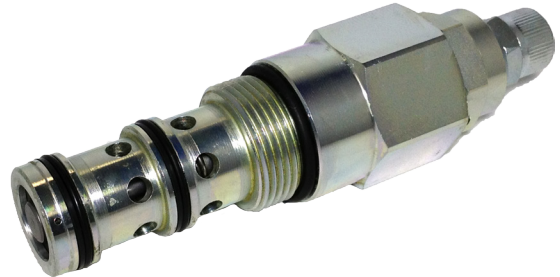

APPLICATIONS

Single counterbalance valves are normally used when the load is unidirectional, such as aerial lifts, cranes, or winches. In load holding applications, they can be used as hose-break valves when installed near or within an actuator. Dual cartridges can be used for controlling loads bi-directionally in motor applications, or for cylinders going over center. Since this valve is piloted at port 1, no cross port drilling is required when dual cartridges are mounted nose to nose in an HIC.

SPECIFICATIONS

Rated pressure	350 bar [5075 psi]*
Rated flow at 22 bar (319 psi)	60 l/min [16 US gal/min]
Leakage	10 drops/min @ at 70% of crack pressure
Weight	0.21 kg [0.47 lb]
Pilot ratio	4.1:1, 7.1:1
Cavity	NCS06-3

* 350 bar with steel housing
 210 bar with aluminum housing

SCHEMATIC

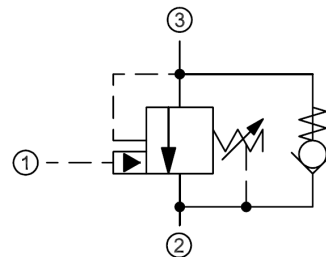

PERFORMANCE

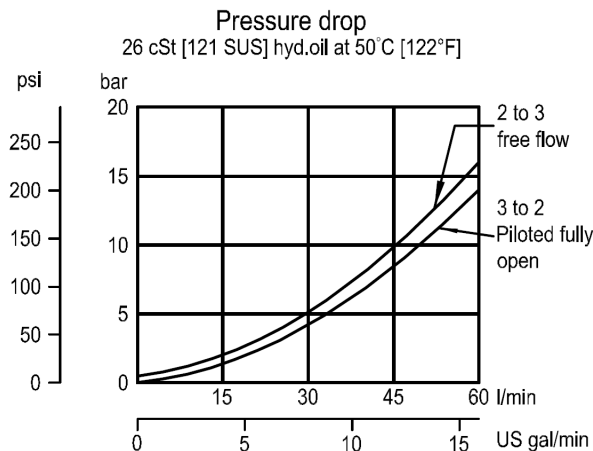

DIMENSIONS

mm [in]

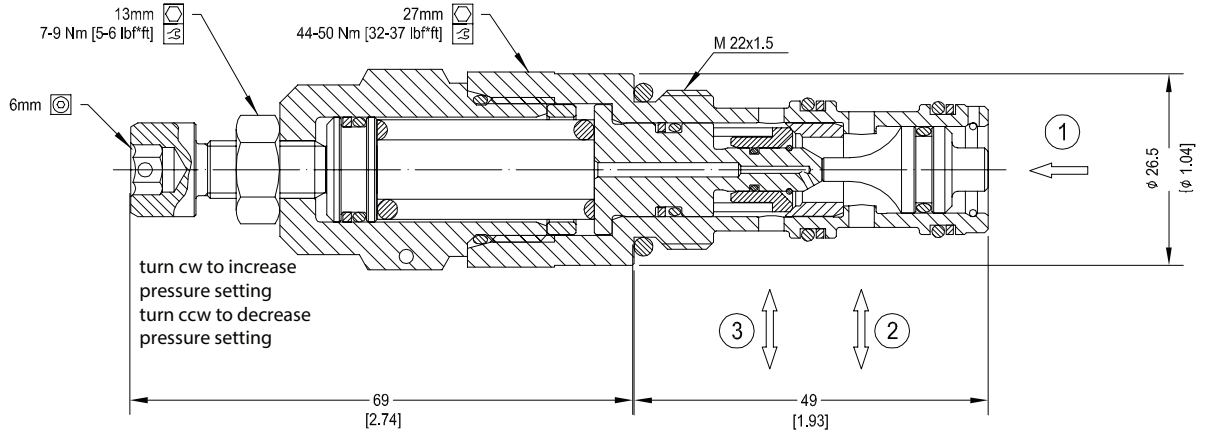

EXAMPLE CIRCUITS

Load Holding - Single Actuator

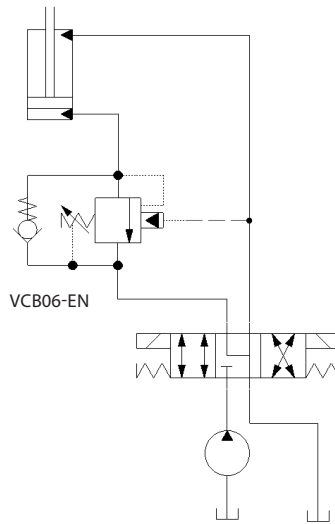

Counterbalance - Double Actuator

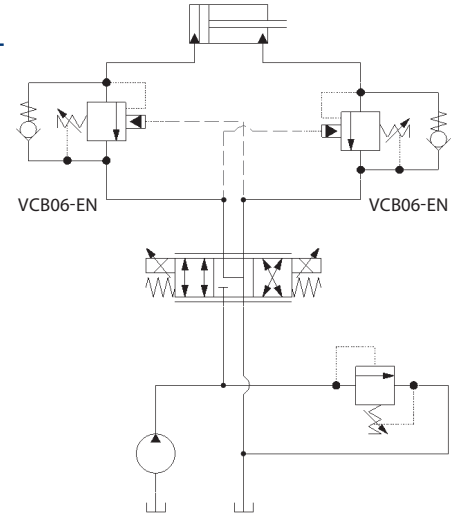

ORDERING INFORMATION

VCB06 - EN - 2 - A - 00 - B - XXX

VCB06-EN: Counterbalance Valve, Pilot Port 1, 6 size (metric), external adjustment, hydraulic vent

Code	Pressure Range bar (psi)
1	25-140 [363-2030]
2	70 - 210 [1015-3045]
3	105 - 350 [1523-5075]

Code	Pilot Ratio
A	7.1:1
B	4.1:1

Code	Seal Material	Seal Kit
B	Buna-N	230000070
V	Viton	230000110

Crack Pressure Setting [in bar]

XXX: No factory setting / no stamping

For customer specified settings, enter value in bar (Example 70 bar = 70; 125 bar = 125 etc.)

Housing & Ports	Housing Nomenclature
00: Cartridge Only	No Body
SE3B: AL, 3/8 BSP	NCS06-3-SE3B
SE4B: AL, 1/2 BSP	NCS06-3-SE4B
SE6S: AL, #6 SAE	NCS06-3-SE6S
SES6S: Steel, #6 SAE	NCS06-3-SES6S
SE8S: AL, #8 SAE	NCS06-3-SE8S