

Sockets

Electric Plug and Socket Connectors

For pressure switches, level switches, flow sensors, directional control valves and filters

DIN EN 175301-803/ISO 4400



DIN EN 175201-804



M12×1



Electric plugs or sockets are required for the actuation of various models of hydraulic equipment used in the field of central lubrication technology and for the evaluation of switching signals.

Overview

Overview Sockets

Order No.	Standard design / type	Application								
		Pressure switch	Flow sensor	Filter monitor	Lubricant level switch	Piston distributor	Oil-streak sensor	Flow monitor	Directional control valve	Cycle switch
179-990-034	DIN EN 175301-803 A/ISO 4400	•	•	•	•					
179-990-110								•		
179-990-111								•		
179-990-147			•	•	•	•				
179-990-657										•
179-990-416	DIN EN 175301-803 A/ISO 4400 (with integrally extruded line)								•	
179-990-452		•	•	•	•					
179-990-200	DIN EN 175201-804	•	•	•	•			•		
179-990-371 straight	4-pole, M12×1	•	•	•	•	•	•	•		•
179-990-372 angled		•	•	•	•	•	•	•	•	•
179-990-600 straight	4-pole, M12×1 (with integrally extruded line)	•	•	•	•	•	•	•		•
179-990-601 angled		•	•	•	•	•	•	•	•	•
179-990-381 straight	3-pole, M12×1 (with integrally extruded line)	•	•	•	•	•	•	•		•
179-990-382 angled		•	•	•	•	•	•	•	•	•

Accessories for socket 179-990-200

LED insert (2 LED version), order No. 179-990-299+924 (24 V DC)

LED insert (3 LED version), order No. 179-990-203+924 (24 V DC)

CAUTION

The important information on product usage located on the back cover applies to all systems described in this brochure.

Socket to DIN EN 175301-803 A/ISO 4400

Supplied with flat packing and fixing screw

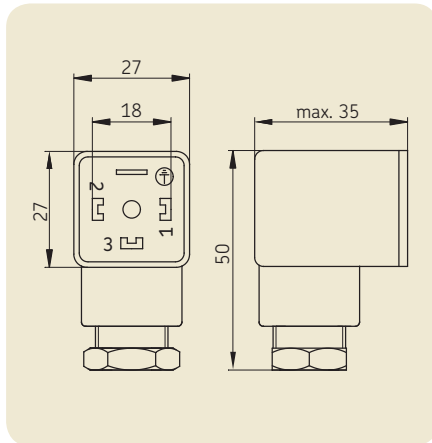

Circuit diagram 179-990-034 / -147

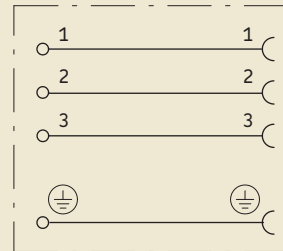

Technical data

Order No.	179-990-034 / 179-990-110 / 179-990-111 / 179-990-147
Version	insert rotatable 4×90°
Poles	3 + PE
Operating display	–
Max. operating current	10 A
Housing	PA, black
Cable gland	PG 11 / PG 9 *)
Conductor cross section	max. 1.5 mm ²
Type of terminal	screws
IP enclosure DIN40050	IP 65 (installed)
Temperature range	–40 to +80 °C
Seal	attached, NBR

Order No.	179-990-034 / 179-990-147
Max. rated operating voltage	230 V AC/DC
Approval	UL-SEV
Line diameter	6 to 9 mm / 4.5 to 7 mm

Order No	179-990-110
Max. rated operating voltage	230 V AC/DC
Approval	–
Line diameter	6 to 8 mm

Order No	179-990-111
Max. rated operating voltage	24 V DC
Approval	–
Line diameter	6 to 8 mm

Circuit diagram 179-990-110

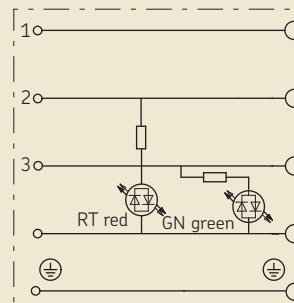

Circuit diagram 179-990-111

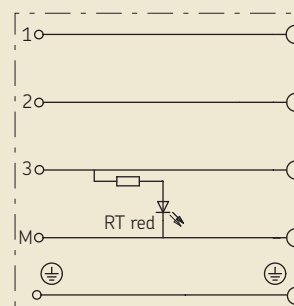

Technical data

Order No.	179-990-657
Version	insert rotatable 4×90°, varistor
Poles	2 + PE
Operating display	–
Max. rated operating voltage	120 V AC/DC
Max. operating current	10 A
Housing	PA, black
Approval	–
Cable gland	PG 11 *)
Conductor cross section	max. 1.5 mm ²
Line diameter	6 to 9 mm
Type of terminal	screws
IP enclosure DIN40050	IP 65 (installed)
Temperature range	–40 bis +80 °C
Seal	attached, silicone

Circuit diagram 179-990-657

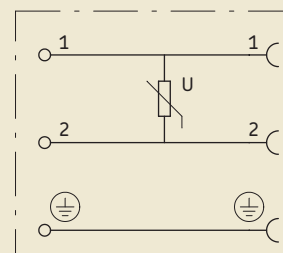

*) PG = heavy gauge conduit thread

Socket to DIN EN 175301-803 A/ISO 4400

Supplied with flat packing and fixing screw

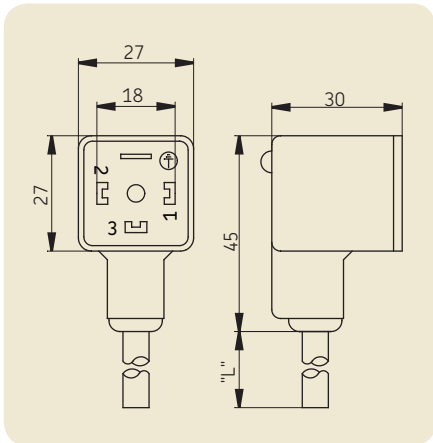

Technical data

Order No.	179-990-452
Version	3 m line 5×0.75 mm ²
Poles	3 + PE
Operating display	2 in 1 LED yellow/green, ~ 10 mA
Max. rated operating voltage	24 V DC
Max. operating current	4 A
Housing	PA, black
Approval	UL-SEV
Line diameter	~ 7 mm
Power lead	3 m • 5×0.75 mm ² . PUR • grey
Color coding	black with white numbers + gnye
IP enclosure DIN 40050	IP 67 (installed)
Temperature range	-20 to +80 °C
Seals	integrated

Circuit diagram 179-990-452

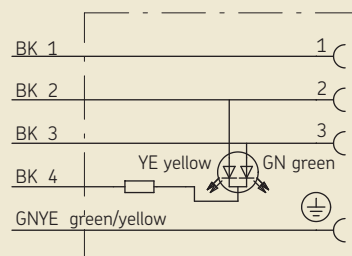

Technical data

Order No.	179-990-416
Vision	3 m line 3×0.75 mm ²
Poles	2 + PE
Operating display	LED yellow, ~ 12 mA
Max. rated operating voltage	24 V AC/DC
Max. operating current	4 A
Housing	PA, black
Approval	UL-SEV
Line diameter	~ 7 mm
Power lead	3 m • 3×0.75 mm ² . PUR • grey
Color coding	black with white numbers + gnye
IP enclosure DIN 40050	IP 67 (installed)
Temperature range	-20 to +80 °C
Seals	integrated

Circuit diagram 179-990-416

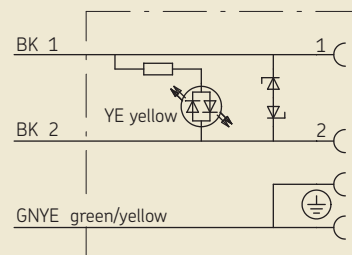

Socket to DIN EN 175201-804

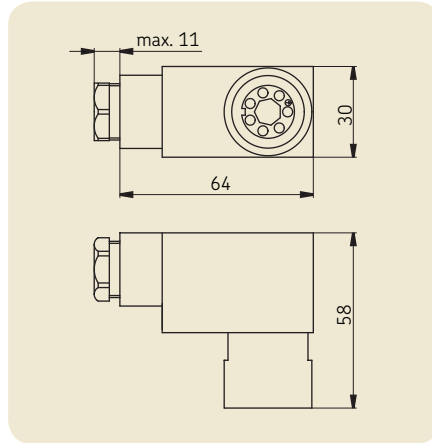

Technical data

Socket **without** LED insert

Order No.	179-990-200
Poles	6 + PE
Operating display	without
Max. rated operating voltage	250 V AC/DC
Max. operating current	10 A
Housing	PA, transparent
Approval	VDE
Cable gland	PG 11 *)
Conductor cross section	max. 1.5 mm ²
Line diameter	7 to 9 mm
Type of terminal	screws
IP enclosure DIN40050	IP 65 (installed)
Temperature range	-40 to +90 °C
Seals	integrated

*) PG = heavy gauge conduit thread

Circuit diagram 179-990-200

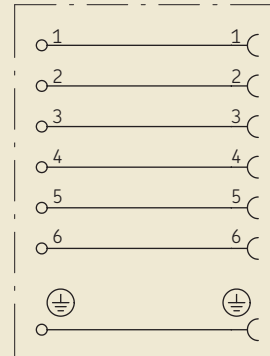

Technical data

Accessory LED insert
for socket 179-990-200

Order No.

179-990-299

Version	2 LED's
Operating display	2 LED's gr/ye
Max. operating current	24 V DC

Order No.

179-990-203

Version	3 LED's
Operating display	3 LED's gr/ye/rd
Max. operating current	24 V DC

179-990-299



179-990-203



Circuit diagram 179-990-299

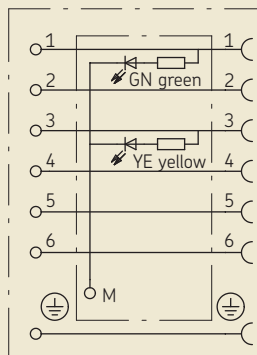

Circuit diagram 179-990-203

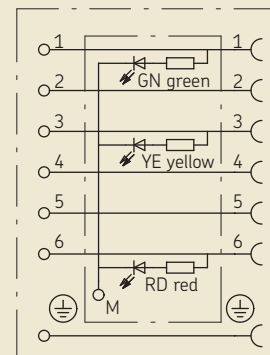

Please note!

The LED insert can only be used for 24 V DC only and must be ordered separately.

Socket M12x1

Type A straight

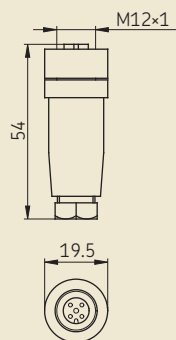

Type B angled

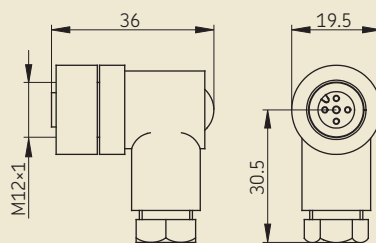

Type C straight

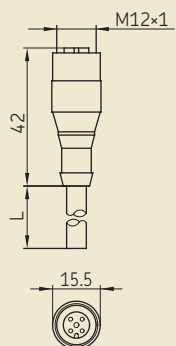

Type D angled

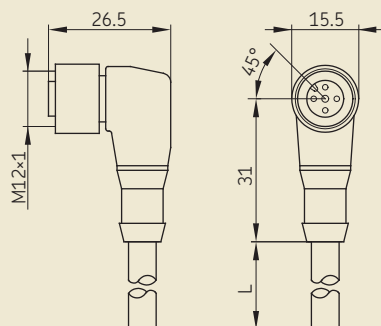

Socket M12×1

Technical data

Order No.	179-990-371 / 179-990-372
Version	A / B
Poles	4
Max. rated operating voltage	250 V AC/DC
Max. operating current	4 A
Housing	PBT-GF, black / PA, black
Approval	—
Conductor cross section	max. 0.75 mm ²
Line diameter	4 to 6 mm
Type of terminal	screws
Power lead	—
Color coding	—
IP enclosure DIN40050	IP 67 (installed)
Temperature range	−40 to +85 °C
Seal material (O-ring)	integrated

Circuit diagram 179-990-371 / -372

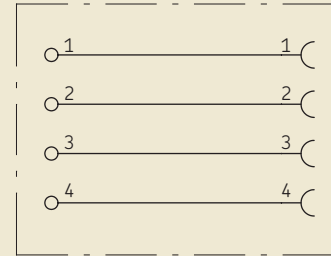

Technical data

Order No.	179-990-600 / 179-990-601
Version	C / D
Poles	4
Max. rated operating voltage	250 V AC / 300 V DC
Max. operating current	4 A
Housing	—
Approval	UL-CSA
Conductor cross section	—
Line diameter	5 mm
Type of terminal	—
Power lead	5 m • 4×0.34 mm ² , PUR
Color coding	cf. circuit diagram
IP enclosure DIN40050	IP 68 (installed)
Temperature range	−25 to +90 °C
Seal material (O-Ring)	integrated, FKM (FPM)

Circuit diagram 179-990-600 / -601

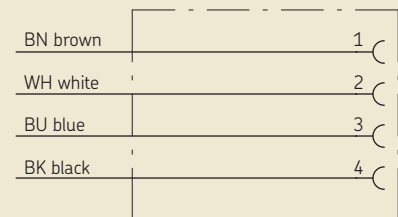

Technical data

Order No.	179-990-381 / 179-990-382
Version	C / D
Poles	3
Max. rated operating voltage	10 to 30 V AC/DC
Max. operating current	4 A
Housing	—
Approval	UL-CSA
Conductor cross section	—
Line diameter	5 mm
Type of terminal	—
Power lead	5 m • 3×0.34 mm ² , PUR/PVC
Color coding	cf. circuit diagram
IP enclosure DIN40050	IP 68 (installed)
Temperature range	−25 to +90 °C
Seal material (O-Ring)	integrated, FKM (FPM)

Circuit diagram 179-990-381 / -382

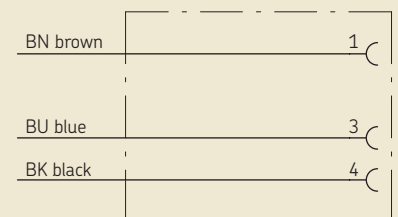

Contact assignments 179-990-371 / -372 / -600 / -601

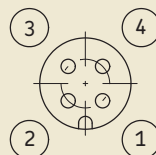

Viewing the plug

Contact assignments 179-990-381 / -382

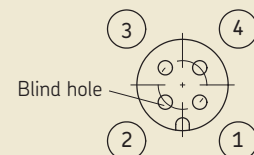

Viewing the plug

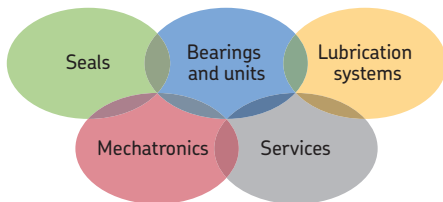

The Power of Knowledge Engineering

Drawing on five areas of competence and application-specific expertise amassed over more than 100 years, SKF brings innovative solutions to OEMs and production facilities in every major industry worldwide. These five competence areas include bearings and units, seals, lubrication systems, mechatronics (combining mechanics and electronics into intelligent systems), and a wide range of services, from 3-D computer modelling to advanced condition monitoring and reliability and asset management systems. A global presence provides SKF customers uniform quality standards and worldwide product availability.

! Important information on product usage

All products from SKF may be used only for their intended purpose as described in this brochure and the operating instructions. If operating instructions are supplied together with the products, they must be read and followed.

Not all lubricants can be fed using centralized lubrication systems. SKF can, on request, inspect the feedability of the lubricant selected by the user in centralized lubrication systems. Lubrication systems and their components manufactured by SKF are not approved for use in conjunction with gases, liquefied gases, pressurized gases in solution, vapors or such fluids whose vapor pressure exceeds normal atmospheric pressure (1 013 mbar) by more than 0,5 bar at their maximum permissible temperature.

In particular, we call your attention to the fact that hazardous materials of any kind, especially the materials classified as hazardous by EC Directive 67/548/EEC, Article 2, Para. 2, may only be filled into SKF centralized lubrication systems and components and delivered and/or distributed with the same after consultation with and written approval from SKF.

Further brochures:

1-9201-EN *Transport of Lubricants in Centralized Lubrication Systems*

SKF Lubrication Systems Germany GmbH

Berlin Plant
 Motzener Str. 35/37 · 12277 Berlin
 PO Box 970444 · 12704 Berlin
 Germany

Tel. +49 (0)30 72002-0
 Fax +49 (0)30 72002-111

This brochure was presented to you by:

© SKF is a registered trademark of the SKF Group.

© SKF Group 2014

The contents of this publication are the copyright of the publisher and may not be reproduced (even extracts) unless prior written permission is granted. Every care has been taken to ensure the accuracy of the information contained in this publication. However, no liability can be accepted for any loss or damage whether direct, indirect or consequential, arising out of use of the information contained herein.

PUB LS/P2 12600 EN • July 2014 • 1-1730-EN

