

Accessories for Minimal Quantity Metering for chain lubrication and surface wetting

Brush

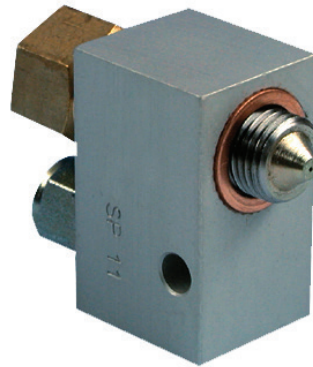

Spray head



Flow volume divider

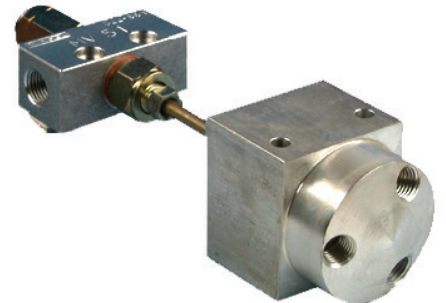

Nozzles

Pinpoint application of metered quantities of oil

Brushes

Storage of lubricant, continuous application

Spray and mixing heads

Even spraying of lubricant with the help of air

Flow volume dividers

Division of a continuous oil+air current into 2, 3, 4, 5 or 6 equal quantities

See illustration on page 2 to see these accessories in a system.

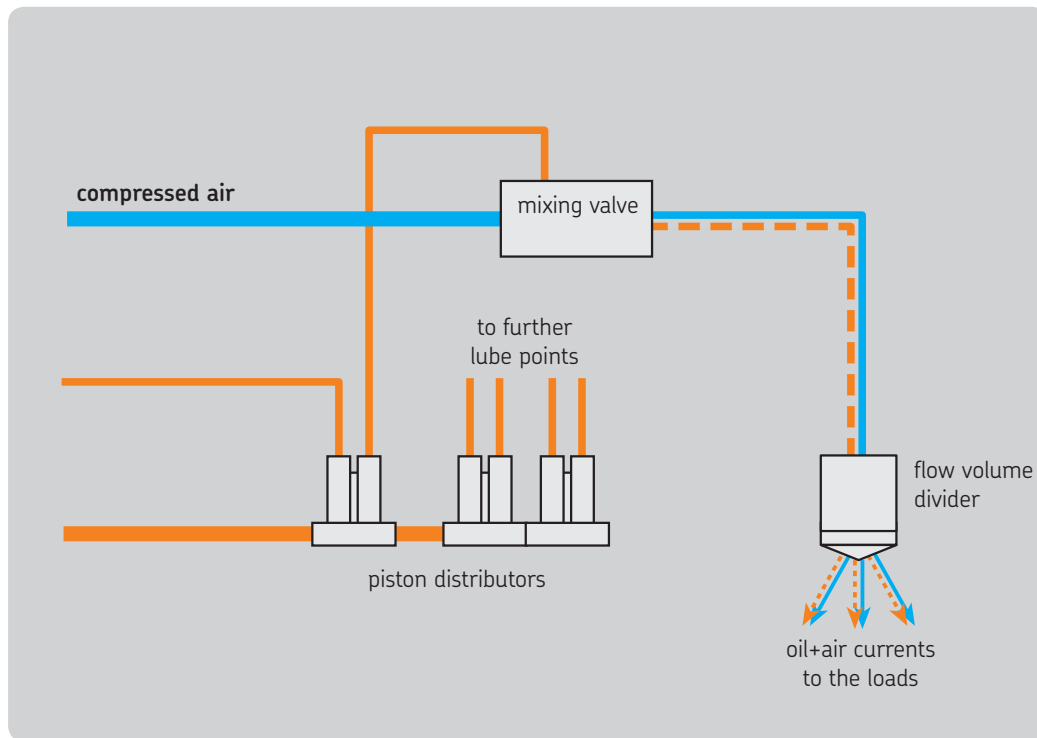

Nozzles with and without check valve for pinpoint application of a metered quantity of oil

857-420-003 / 857-420-004

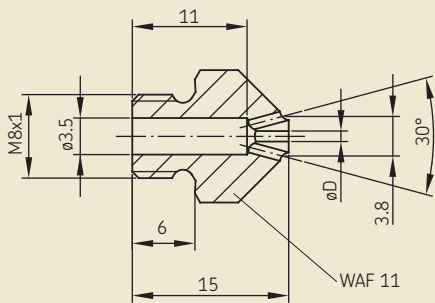

AC-A-405

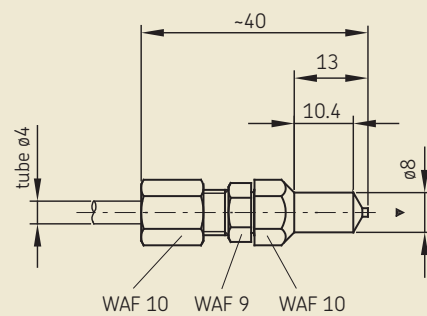

Nozzles

Order No.	Number of outlet ports	øD [mm]
857-420-003	1	0.6
857-420-004	3	1.0
AC-A-405	1	
AC-A-406	1	

AC-A-406

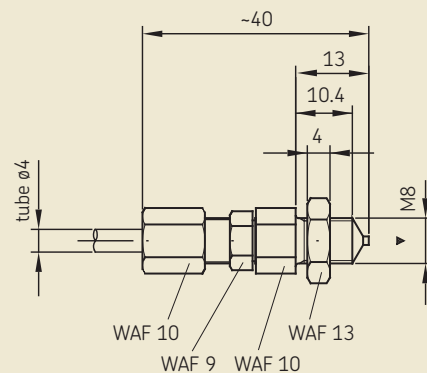

Spray heads with check valve, without metering of their own

A metered quantity of oil is fed to a current of air in spray heads, which are always used when a fixed connection of the secondary line to the lube point is not possible, e.g. for the lubrication of chain links, gears, tools and workpieces.

The oil is apportioned by piston distributors installed between the pump and spray heads.

Spray heads

Order No.	Number of bores
SP11	1
SP13	3
501-100-009	1
501-100-010	3

Connection pieces tapped for solderless tube connection for air and oil line

Order No. **402-006** for tube 2.5 mm diam.

Order No. **404-003** for tube 4 mm diam.

Order No. **406-158** for tube 6 mm diam.

Washer, order No. **DIN7603-A8x11.5-CU**

Please, see important product usage information on the back cover.

SP11 / SP13

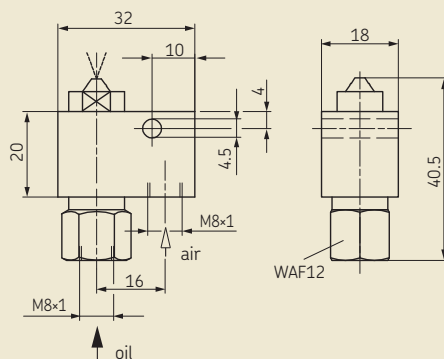

501-100-009 / 501-100-010

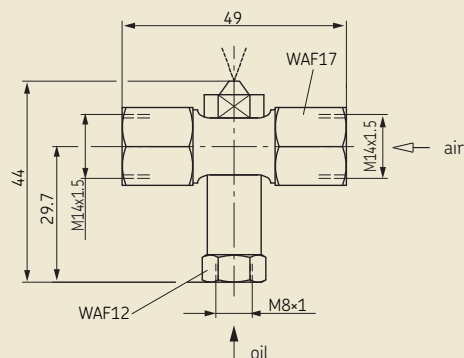

Brushes

Fig. 1

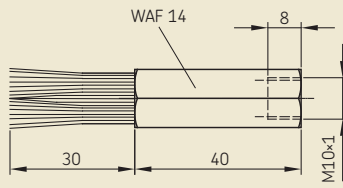

Fig. 2

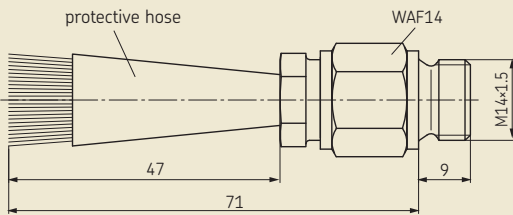

Fig. 3

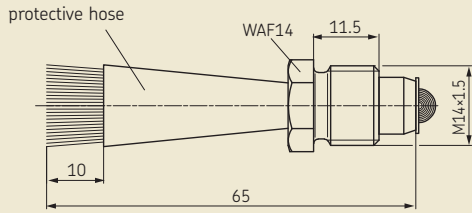

Fig. 4

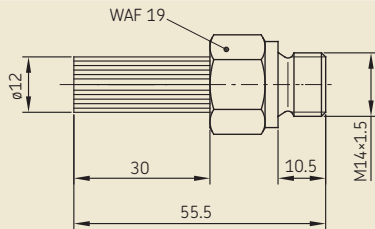
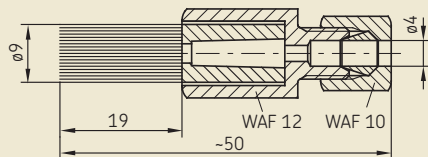

Fig. 5



Brushes

Order No.	Brush material	Protective hose	Fig.
992-000-289	Perlon, soft	-	1
995-001-577	horse hair	-	2
995-001-618	horse hair	ja	2
995-001-626	horse hair	-	3
995-001-627	horse hair	ja	3
992-000-280	PA	-	4
24-2580-2030	PA 6.6	-	5

Order No.	Brush material	L1	L2	øD	Fig.
169-000-193	corrugated	25	45	28	6
169-000-194	cast steel wire	25	53	16	6

992-000-171	horse hair				7
-------------	------------	--	--	--	---

Fig. 6

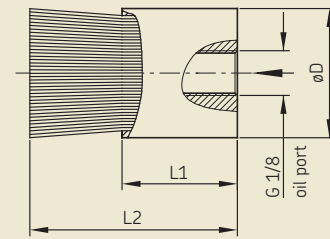
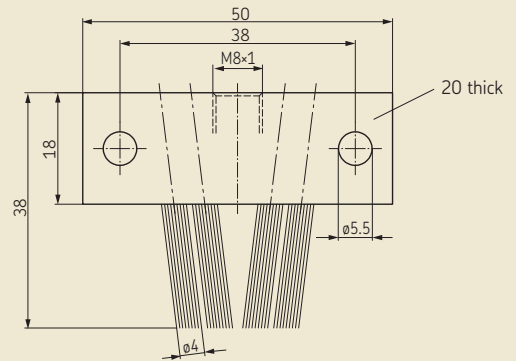

Fig. 7



Mixing heads without metering of their own

to supply one load

The pressure line and secondary line come together in mixing heads. The mixing heads can be introduced directly into the consuming point's thread.

Mixing heads require a metering piston distributor of an intermittently operated single-line central lubrication system or an injection oiler in order to supply oil (cf. leaflet 1-5012-4-EN).

Since no oil is deposited in the pressure line, there is no "cloud of oil haze" when a system is started up after a shutdown.

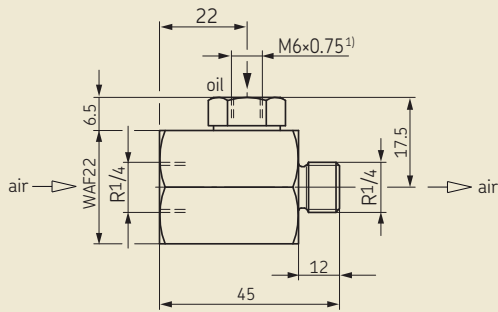

1) Port tapped for solderless tube connection
M6x0.75 for 2.5 mm diam. tube

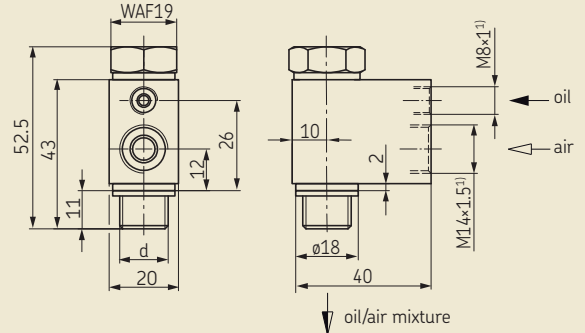

1) Port tapped for solderless tube connection
M8x1 for 4 mm diam. tube, M14x1.5 for 8 mm diam. tube

Mixing heads for 2.5 mm diam. secondary line

Order No.

161-300-308

Mixing heads for 4 mm diam. secondary line

Order No. d

161-300-301 M14x1.5
161-300-302 G 1/4 A

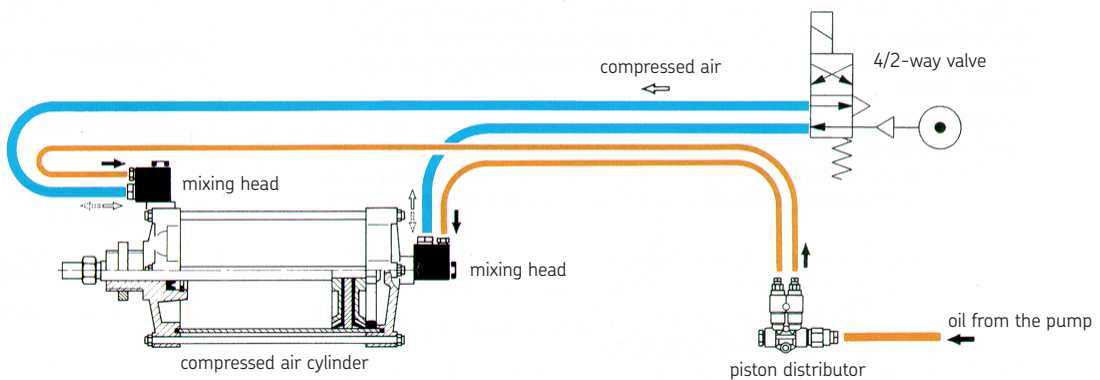

Flow volume dividers

For uniform apportionment of oil+air or fluid grease+air currents to 2 or more lube points. The outlet ports should be as free of pressure as possible, but differences in secondary-line length of up to 0.5 m are of no consequence.

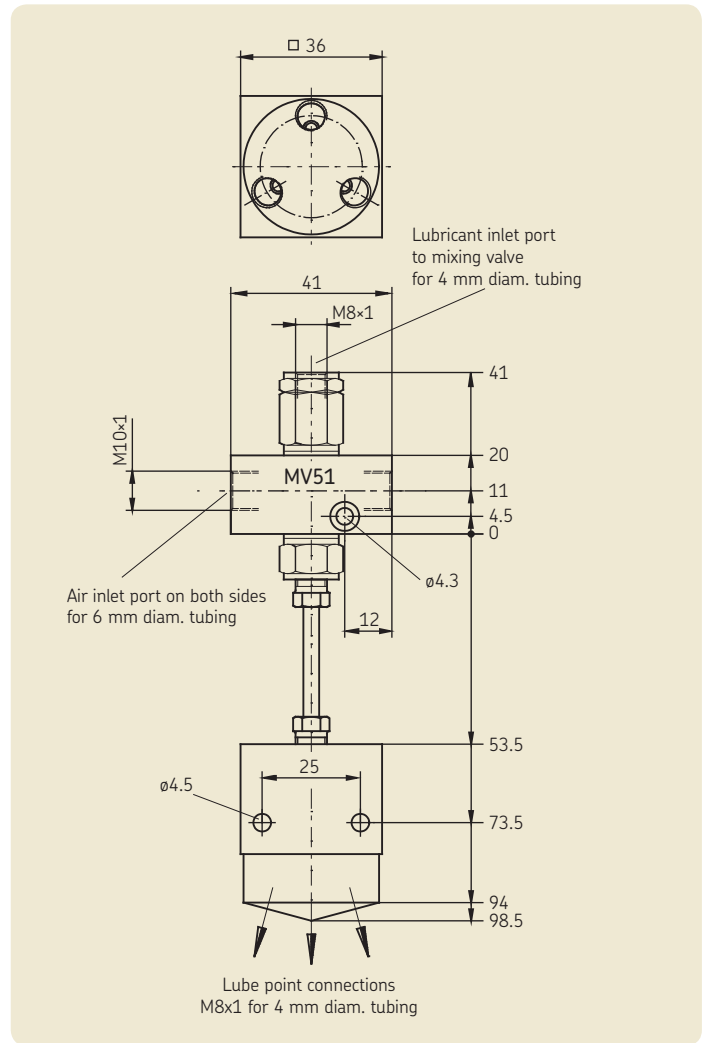
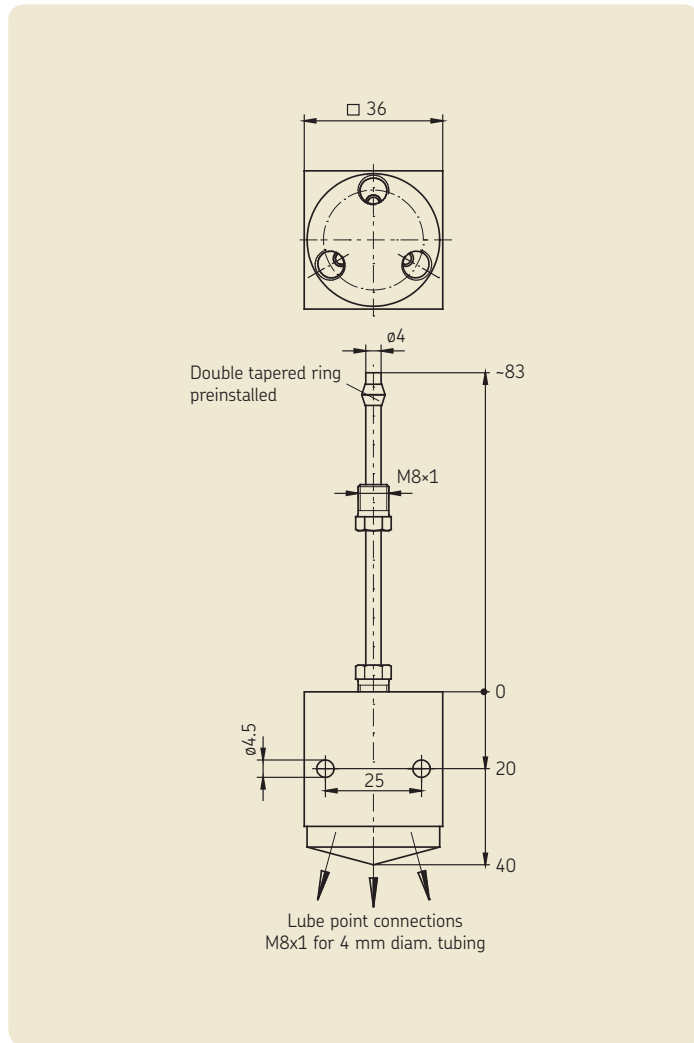

Order No.	Lube points
169-000-182	2
169-000-183	3
169-000-184	4
169-000-185	5
169-000-186	6

Mounting position preferably vertical

Order No.	Lube points
169-000-252	2
169-000-253	3
169-000-254	4
169-000-255	5
169-000-256	6

Mounting position preferably vertical

Order No. 1-5012-5-EN

Subject to change without notice! (07/2014)

Important product usage information

All products from SKF may be used only for their intended purpose as described in this brochure and in any instructions. If operating instructions are supplied with the products, they must be read and followed.

Not all lubricants are suitable for use in centralized lubrication systems. SKF does offer an inspection service to test customer supplied lubricant to determine if it can be used in a centralized system. SKF lubrication systems or their components are not approved for use with gases, liquefied gases, pressurized gases in solution and fluids with a vapor pressure exceeding normal atmospheric pressure (1013 mbars) by more than 0.5 bar at their maximum permissible temperature.

Hazardous materials of any kind, especially the materials classified as hazardous by European Community Directive EC 67/548/EEC, Article 2, Par. 2, may only be used to fill SKF centralized lubrication systems and components and delivered and/or distributed with the same after consulting with and receiving written approval from SKF.

Further brochures

1-9201-EN Transport of Lubricants in Centralized Lubrication Systems

SKF Lubrication Systems Germany GmbH

Motzener Strasse 35/37 · 12277 Berlin · Germany
PF 970444 · 12704 Berlin · Germany
Tel. +49 (0)30 72002-0 · Fax +49 (0)30 72002-111
www.skf.com/lubrication

This brochure was presented by:

® SKF is a registered trademark of the SKF Group.

© SKF Group 2014

The contents of this publication are the copyright of the publisher and may not be reproduced (even extracts) unless prior written permission is granted. Every care has been taken to ensure the accuracy of the information contained in this publication but no liability can be accepted for any loss or damage whether direct, indirect or consequential arising out of the use of the information contained herein.

