

Protection and Control of Solid Fuel Boilers



thermal relief valves
thermostatic valves and pump stations
draft regulators



■ BOILER PROTECTION AGAINST OVERHEATING

Solid fuel boilers may get overheated during operation, mostly due to a power failure. This danger can be avoided in two ways: either by **cooling the boiler via a thermostatic valve** that needs no el. energy for its operation, or by **a UPS** that supplies electric energy for the circulation pump.

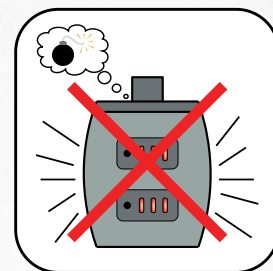

■ BOILER PROTECTION AGAINST FOULING AND CORROSION

During burning steam is released from the fuel. If the boiler is hot enough, the steam leaves through the chimney together with the flue gas. However, if the flue gas gets cooler on the boiler mantle, steam condensation occurs there. The condensate may contain very aggressive combustion products that cause fast corrosion and deposit formation on heat transfer surfaces (tarring).

By mixing cool return water from a heating system with hot water from the boiler flow the boiler heat transfer surfaces are kept warmer and no condensation occurs. This makes their service life significantly longer and the boiler efficiency higher.

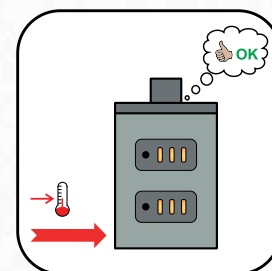

■ BOILER OUTPUT CONTROL

Thermostatic draft regulators keep the outgoing temperature from a solid fuel boiler at the value selected by the regulator knob. They control combustion air dampers via chains, controlling this way the boiler output. Their advantage is a robust, mechanically sturdy and thermally resistant build. Their double scale enables horizontal as well as vertical installation. They are fitted with high quality thermostatic elements made by a French manufacturer that guarantee precise operation and a long service life.

Electric controlled regulators work in the same manner, moreover they can reduce outgoing temperature from a boiler on electric signal. This way the boiler temperature and output can be controlled by a room thermostat or another electronic controller.

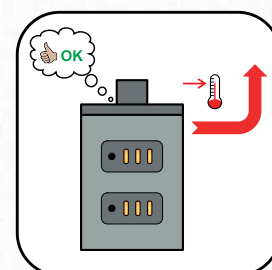

CONTENTS

BOILER PROTECTION AGAINST OVERHEATING

Two-way Thermal Relief Valves:

- 2** **DBV2**
Thermal Safety Relief Valve
- 3** **DBV1**
Thermal Relief Valve

One-way Thermal Relief Valves:

- 4** **BVTS**
Thermal Safety Relief Valves with capillary
- 6** **JBV1**
Thermal Relief Valve

PROTECTION AGAINST BOILER CORROSION AND FOULING

Load Valves:

- 10** **TSVB**
Valves for return temperature control, with automatic by-pass balancing
- 10** **TSV**
Valves for return temperature control, an external by-pass balancing valve needed

Insulated Load Units

- 20** **REGOMAT E**
Load Unit with thermostatic mixing
- 26** **CSE MIX**
Load Unit with electric actuated mixing
- 27** **CSE MIX-FIX**
Load Unit with electronic controlled mixing

Circulation pumps performance curves:

- 28** **Grundfos UPM3**
- 29** **Wilo Yonos Para**

BOILER OUTPUT CONTROL

- 30** **RT4**
Thermostatic Draft Regulator
- 32** **RT3E**
Thermostatic Draft Regulator, electric operated

BOILER PROTECTION AGAINST OVERHEATING

Two-way Thermal Relief Valves



DBV2 Thermal Safety Relief Valve

A thermal relief safety valve designed for cooling solid-fuel boilers **with no cooling heat exchanger**. The valve is equipped with **two stages** – the lower stage discharges hot water from the heat source outlet into sewer, the upper stage lets cold water into the heat source, cooling it down. When the temperature reaches 97°C, the valve opens both the stages, discharging hot water from the heat source into sewer through the lower stage and letting cold water from the mains into the return line through the upper stage.

In order to work properly, the valve shall be installed in a place where the highest temperature is reached in case of overheating - usually directly in a top section of the boiler or in an outlet pipe close to the boiler.

The thermostatic element from a renowned French manufacturer is located directly in heating water, so its **reaction to heating water temperature fluctuations is almost immediate**. The valve has no capillary that could get damaged during installation. The valve has a push button for manual opening (like safety valves).

Valve opening and closing is controlled by two independent thermostatic elements – the valve will dissipate sufficient excess heat even if one of them failed.

Functional tests are performed on each valve in production.

The valve meets the requirements set by the Pressure Equipment Directive (PED) 97/23/EC and EN 14597. It is a STW device of Th type as defined by EN 14597, so it fulfils the requirements for a device to dissipate excess heat, as of Art. 4.3.8.4, EN 303-5.

Technical Data

OPENING TEMPERATURE	97 ± 2 °C
MAX. WORKING PRESSURE - HEATING WATER	4 bar
MAX. WORKING PRESSURE - COLD WATER	6 bar
PIPE CONNECTION	G 3/4" M
HEAT SOURCE CONNECTION	R 3/4" M tapered thread
WEIGHT	0.70 kg
CODE	14 043

The valve is patented in many European countries.



Dimensions

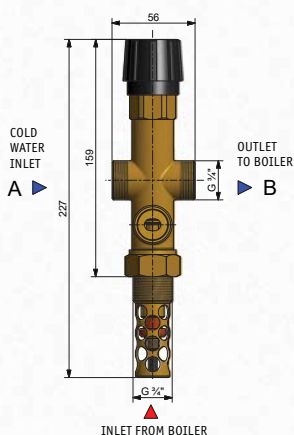

Connection in a system

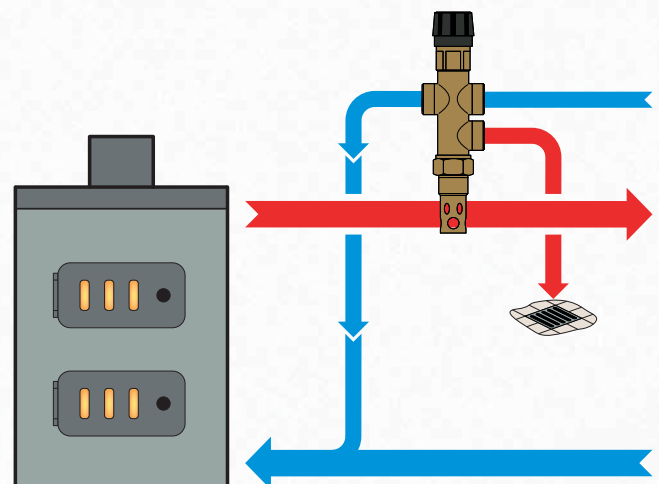

BOILER PROTECTION AGAINST OVERHEATING

Two-way Thermal Relief Valves



DBV1 Thermal Relief Valve

A thermal relief valve designed for cooling solid-fuel boilers with **no cooling heat exchanger**. When the temperature reaches 97°C, the valve opens and lets cold water in from the mains. It cools the boiler down, preventing its overheating. Hot water is discharged into a sewer.

In order to work properly, the valve shall be installed in a place where the highest temperature is reached in case of overheating - usually directly in a top section of the boiler or in an outlet pipe close to the boiler.

The thermostatic element from a renowned French manufacturer is located directly in heating water, so its **reaction to heating water temperature fluctuations is almost immediate**. The valve has a push button for manual opening (like safety valves).

Functional tests are performed on each valve in production.

Technical Data

OPENING TEMPERATURE	97 ± 2 °C
MAX. WORKING PRESSURE - HEATING WATER	4 bar
MAX. WORKING PRESSURE - COLD WATER	6 bar
PIPE CONNECTION	G 3/4" M
HEAT SOURCE CONNECTION	R 3/4" M tapered thread
WEIGHT	0.70 kg
CODE	8 066

The valve is patented in many European countries.



Dimensions

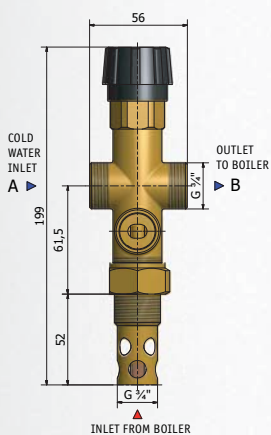

Connection in a system

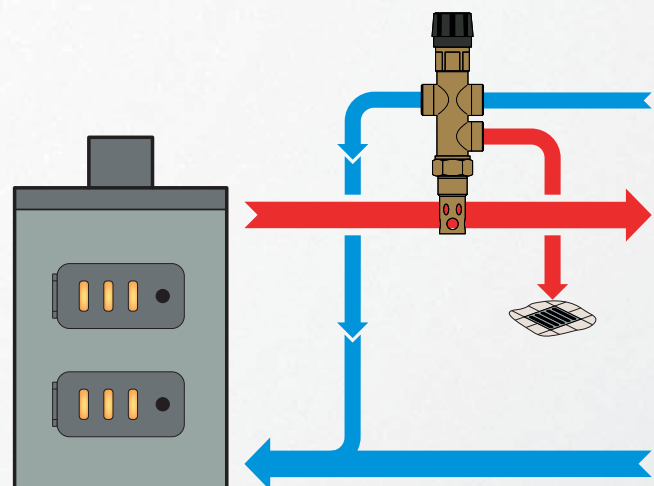

BOILER PROTECTION AGAINST OVERHEATING

One-way Thermal Relief Valves



BVTS Thermal Safety Relief Valves with capillary

Thermostatic valve with a capillary designed for cooling solid-fuel boilers with **a cooling heat exchanger**.

By opening a cold water inlet, the valve removes heat from a boiler cooling heat exchanger, protecting the boiler from overheating in case of emergency. Its opening temperature depends on the valve version (the valve is factory set and cannot be changed by the user).

In order to work properly, the valve sensor shall be installed in a place where the highest temperature is reached in case of overheating - usually directly in a top section of the boiler or in an outlet pipe close to the boiler.

The valve has an activation push button for manual opening. Functional tests are performed on each valve in production.

Technical Data

MAX. WORKING PRESSURE - HEATING WATER	6 bar
MAX. WORKING PRESSURE - COLD WATER	10 bar
CONNECTION THREAD	G 3/4" F
SENSOR SHEATH THREAD	G 1/2" M

The valve meets the requirements set by the Pressure Equipment Directive (PED) 97/23/EC and EN 14597. It is a STW device of Th type as defined by EN 14597, so it fulfils the requirements for a device to dissipate excess heat, as of Art. 4.3.8.4, EN 303-5.

Connection in a system

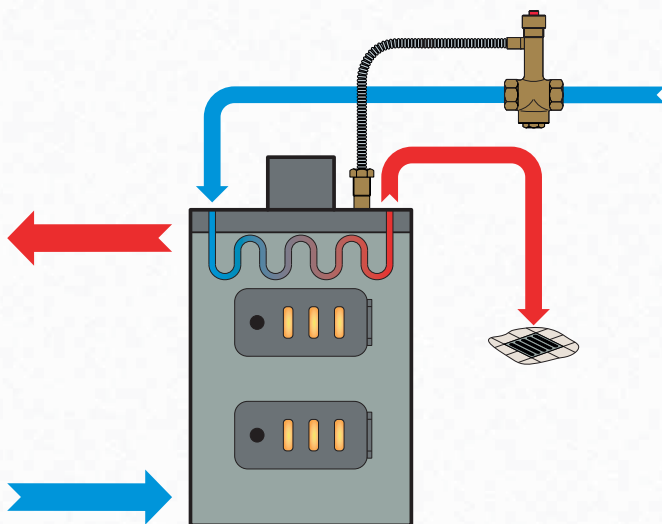

Dimension and versions

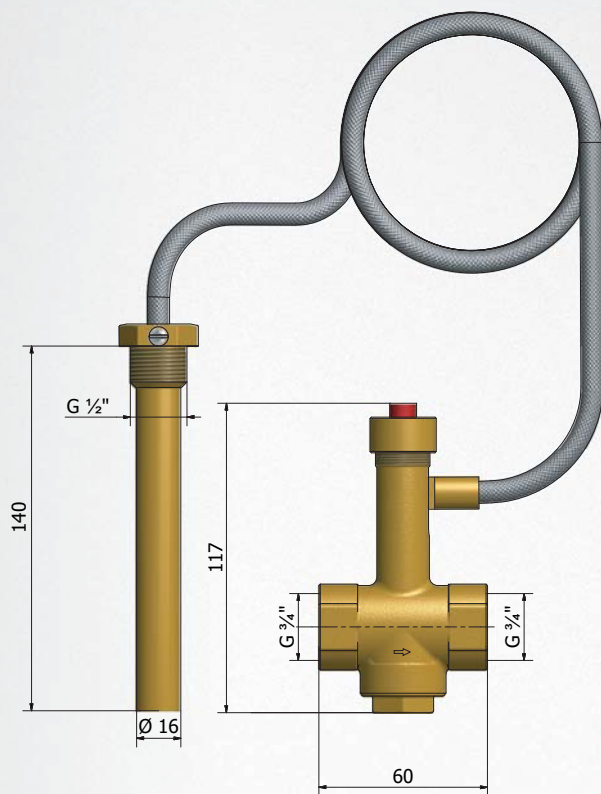

Version	Capillary length [mm]	Capillary design	Valve opening temp. $t \pm 2^\circ\text{C}$ [°C]	Weight [kg]	Code
BVTS 50°C 1.3M O	1 300	detachable	50	0.7	14 473
BVTS 55°C 1.3M	1 300	fixed	55	0.7	14 474
BVTS 65°C 1.3M	1 300	fixed	65	0.7	14 475
BVTS 70°C 1.3M	1 300	fixed	70	0.7	14 476
BVTS 95°C 1.3M	1 300	fixed	95	0.7	14 477
BVTS 95°C 4.0M	4 000	fixed	95	1.0	14 478
BVTS 95°C 1.3M O	1 300	detachable	95	0.7	14 479
BVTS 97°C 1.3M	1 300	fixed	97	0.7	14 480
BVTS 97°C 1.3M NIKL	1 300	fixed	97	0.7	14 713
BVTS 100°C 1.3M O	1 300	detachable	100	0.7	14 481
BVTS 108°C 1.3M	1 300	fixed	108	0.7	14 483

BOILER PROTECTION AGAINST OVERHEATING

One-way Thermal Relief Valves



JBV1 Thermal Relief Valve

A thermal relief valve designed for cooling solid-fuel boilers **with a cooling heat exchanger**. When the temperature reaches 97°C, the valve opens and lets cold water in from the mains that it cools the boiler down **via a cooling heat exchanger**, preventing its overheating. Hot water is discharged into a sewer.

In order to work properly, the valve shall be installed in a place where the highest temperature is reached in case of overheating - usually directly in a top section of the boiler or in an outlet pipe close to the boiler.

The thermostatic element from a renowned French manufacturer is located directly in heating water, so its **reaction to heating water temperature fluctuations is almost immediate**. The valve has no capillary that could get damaged during installation. The valve has a push button for manual opening (like safety valves).

Functional tests are performed on each valve in production.

Technical Data

OPENING TEMPERATURE	97 ± 2 °C
MAX. WORKING PRESSURE - HEATING WATER	4 bar
MAX. WORKING PRESSURE - COLD WATER	6 bar
PIPE CONNECTION	G 3/4" M
HEAT SOURCE CONNECTION	G 1/2" M
WEIGHT	0.70 kg
CODE	8 877

The valve is patented in many European countries.

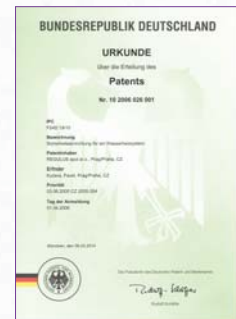

Dimensions

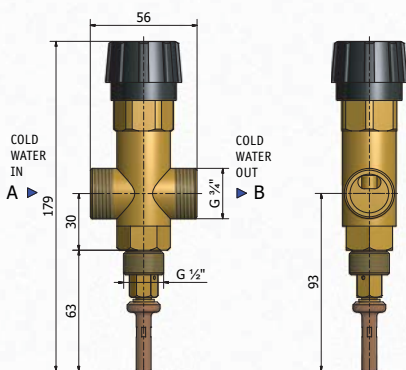

Connection in a system

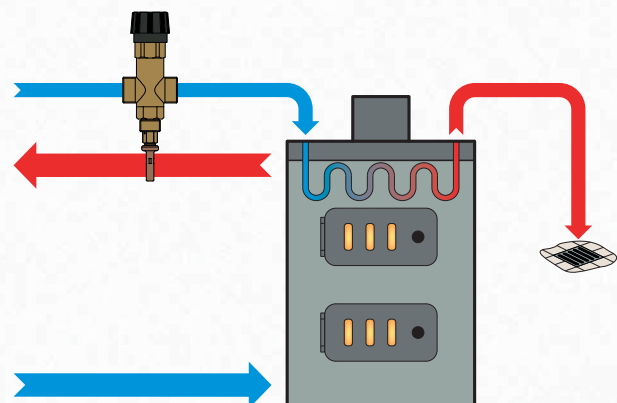

PROTECTION AGAINST BOILER CORROSION AND FOULING

TSV load valves keep a boiler return temperature at least at the valve opening temperature, preventing boiler corrosion and fouling. The boiler then works with higher efficiency and its service life is extended. The valve contains a thermostatic element that facilitates mixing outgoing hot water with return water from a heating system or thermal store.

All valve models for 45°C, 55°C and 65°C are fitted with thermostatic elements with rubber gaskets that guarantee high tightness, preventing microcirculation in periods when the boiler is extinguished. Microcirculation via a boiler is the reason why a thermal store cools down due to heat loss via the boiler to chimney.

All valves feature robust design with large cross sections for heating water flow. That is why they are not inclined to getting clogged when installed into older heating systems.

■ TSV B Valve with automatic by-pass balancing

TSV B valve controls flow through both A and B inlets, closing them tight at end positions. The outlet temperature is kept in the range of 5°C from nominal temperature upwards. This exact control prevents boiler overheating and keeps a steady flow rate through a boiler under any conditions if the system is properly designed. **When restricting the flow through one port, it opens the other one simultaneously.** At the end of the control range, the by-pass (port B) is tightly closed and the inlet from a heating system (port A) fully open. Due to this, the incoming water temperature to a boiler is kept at lower values than with a valve without automatic by-pass control, and so the boiler can work at full power even with very hot return water.

The installation of a TSV B valve is easier and its control more precise than that of valves without automatic balancing. It is very suitable for higher-output boilers.

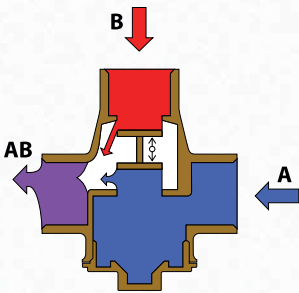

■ TSV Valve with manual by-pass balancing

TSV valve controls flow through both A and B inlets, closing them tight at end positions. **The port B is always open, unrestricted.**

Flow through the by-pass is restricted only by the manually adjusted valve, so the return line temperature can rise disregarded of the temperature reached.

When cold, the inlet from a heating system (port A) is closed by the thermostatic element integrated in the valve. Heating water flows from the boiler through by-pass (port B) and via the valve outlet (port AB) back to the boiler. When the opening temperature of the thermostatic element is reached, it starts opening the inlet from a heating system (port A). Colder water (from port A) starts mixing with hot water (from port B). The thermostatic element controls the cold water inlet (through port A) in such a manner that the outlet temperature does not sink below the valve opening temperature. The inlet from the by-pass (port B) remains permanently open.

In case of a higher return water temperature this may result in blending more hot water from the boiler than necessary which in turn brings very high outlet temperature from the valve (port AB), causing possible boiler overheating. For this reason the by-pass pipe **shall be fitted with a balancing valve that will limit the flow.**

Boiler manufacturer ATMOS recommends that these models of TSV valves are used with his boilers.

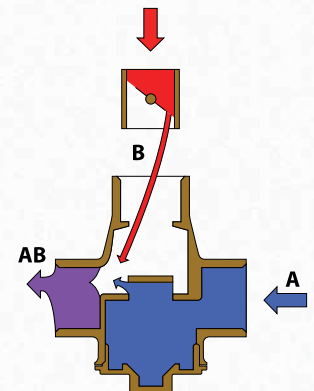

How the TSV outlet temperature depends on the inlet temperature from a heating system

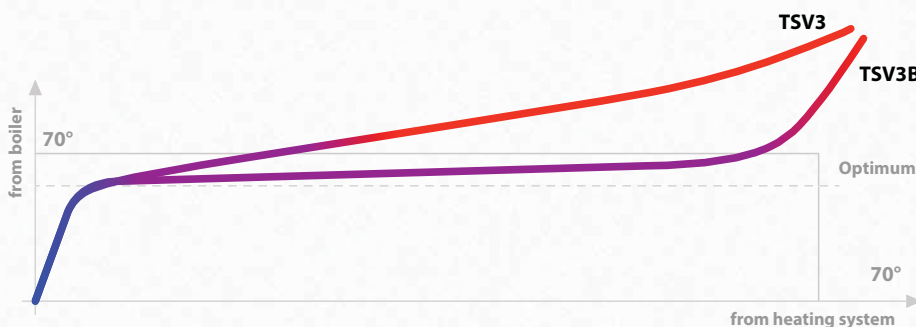

Overview of TSV B valves with automatic by-pass balancing



Model		TSV3B	TSV5B	TSV6B	TSV8B
Nominal diameter DN	[-]	25	32	40	50
Connection size	["]	1" F	5/4" F	6/4" F	2" F
Flow coefficient K_{vs} from A to AB	[m ³ /h]	6.2	7	13.3	15.8
Flow coefficient K_{vs} from B to AB	[m ³ /h]	4.4	4.9	9.6	11.1
Weight	[kg]	0.77	0.87	1.7	1.85
Codes for temperature and tightness					
Opening temperature 45 °C		11 282	11 806	12 974	12 977
Opening temperature 50 °C		15 517	15 520	-	-
Opening temperature 55 °C		11 281	11 807	12 975	12 978
Opening temperature 60 °C		15 518	15 521	-	-
Opening temperature 65 °C		10 080	11 808	12 976	12 979
Opening temperature 70 °C		15 519	15 522	-	-

Overview of TSV valves with manual by-pass balancing



Model		TSV3	TSV5	TSV6	TSV8
Nominal diameter DN	[-]	25	32	40	50
Connection size	["]	1" F	5/4" F	6/4" F	2" F
Flow coefficient K_{vs} from A to AB	[m ³ /h]	6.2	7	13.3	15.8
Flow coefficient K_{vs} from B to AB	[m ³ /h]	10,1	11,5	19,8	27,4
Weight	[kg]	0.75	0.85	1.6	1.75
Codes for temperature and tightness					
Opening temperature 65 °C		10 347	11 804	11 821	11 819
Opening temperature 72 °C		16 029	15 533	16 060	16 061
Opening temperature 77 °C		10 472	11 836	-	-

- in this version not available



Insulation sets

Model		TSV3, TSV3B	TSV5, TSV5B	TSV6, TSV6B	TSV8, TSV8B
Code	[-]	14 979	14 980	11 874	11 875

PROTECTION AGAINST BOILER CORROSION AND FOULING

Load Valves with automatic by-pass balancing



TSV3B

Valves for return temperature control, with automatic by-pass balancing

TSV B load valves mix cool return water from a heating system or thermal store with hot water from a boiler flow, **keeping boiler return water** (i.e. its heat transfer surfaces) at a temperature that will **not allow condensation to occur**. The boiler then works with higher efficiency and its service life is extended.

The valves feature automatic by-pass balancing. The exact control prevents boiler overheating and keeps a steady flow rate through a boiler under any temperature if the system is properly designed. When restricting the flow through one port, it opens the other one simultaneously.

Dimensions

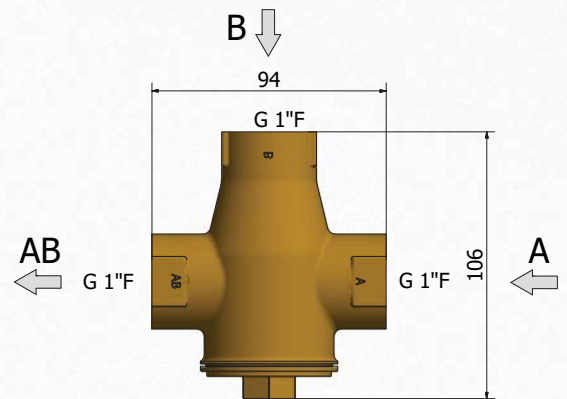

Versions

		TSV3B 45	TSV3B 50	TSV3B 55	TSV3B 60	TSV3B 65	TSV3B 70
OPENING TEMPERATURE	°C	45	50	55	60	65	70
NOMINAL DIAMETER	-	DN25	DN25	DN25	DN25	DN25	DN25
CONNECTION SIZE	--	G 1" F	G 1" F	G 1" F	G 1" F	G 1" F	G 1" F
K_{vs} from A to AB	m ³ /h	6.2	6.2	6.2	6.2	6.2	6.2
K_{vs} from B to AB	m ³ /h	4.4	4.4	4.4	4.4	4.4	4.4
WEIGHT	kg	0.77	0.77	0.77	0.77	0.77	0.77
CODE	--	11 282	15 517	11 281	15 518	10 080	15 519

Connection in a system

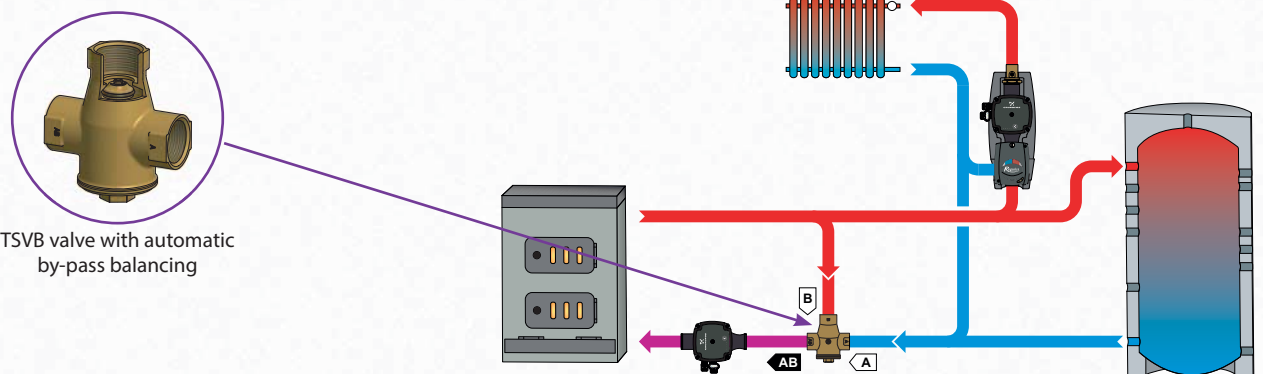

PROTECTION AGAINST BOILER CORROSION AND FOULING

Load Valves with manual by-pass balancing



TSV3

Valves for return temperature control, with manual by-pass balancing

TSV load valves with manual by-pass adjustment mix cool return water from a heating system or thermal store with hot water from a boiler flow, **keeping boiler return water** (i.e. its heat transfer surfaces) at a temperature that will **not allow condensation to occur**. The boiler then works with higher efficiency and its service life is extended.

Balancing of TSV3 valves needs to be performed manually using a balancing valve in the by-pass pipe. Boiler manufacturer ATMOS recommends that these models of TSV valves are used with his boilers.

Dimensions

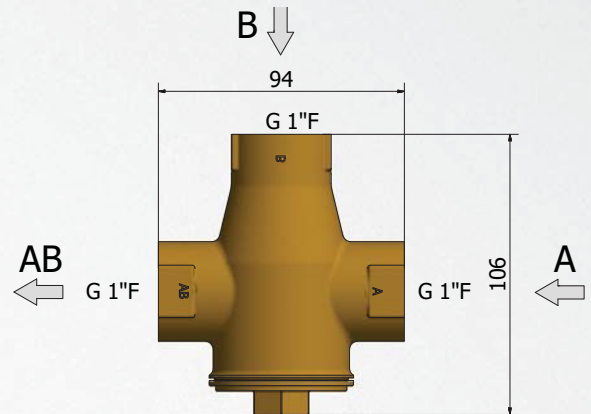

Versions

	TSV3 65	TSV3 72	TSV3 77
OPENING TEMPERATURE	65 °C	72 °C	77 °C
NOMINAL DIAMETER		DN25	
CONNECTION SIZE		G 1" F	
MAX. WORKING PRESSURE		6 bar	
K_{vs} from A to AB		6.2 m ³ /h	
K_{vs} from B to AB		10.1 m ³ /h	
WEIGHT		0.75 kg	
CODE	10 347	16 029	10 742

Connection in a system

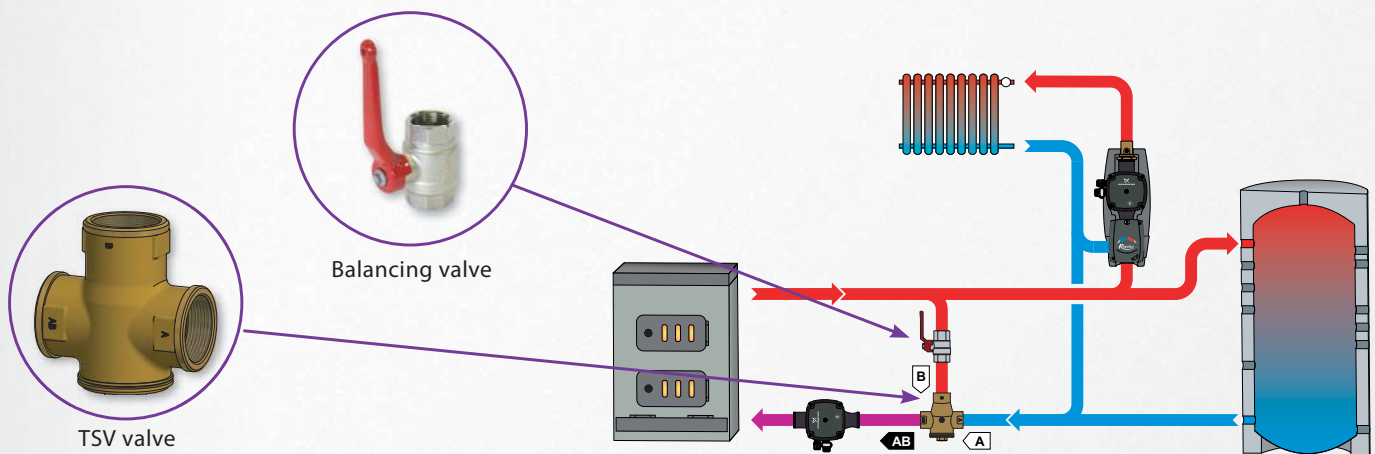

PROTECTION AGAINST BOILER CORROSION AND FOULING

Load Valves with automatic by-pass balancing



TSV3BF

Valves for return temperature control, with automatic by-pass balancing

Load valve with automatic by-pass balancing, with 1" F threads on both A and B inlets. The AB outlet is fitted with a 6/4" F union nut, it involves also a 6/4" F x 1" F adapter. The kit is intended to connect a circulation pump.

Dimensions

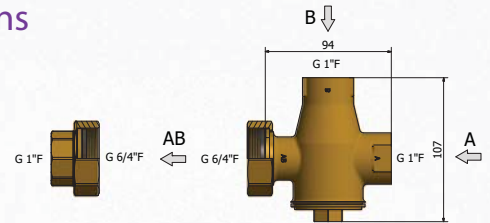

Versions

		TSV3BF 45	TSV3BF 50	TSV3BF 55	TSV3BF 60	TSV3BF 65	TSV3BF 70
OPENING TEMPERATURE	°C	45	50	55	60	65	70
NOMINAL DIAMETER	-	G 1" F	G 1" F	G 1" F	G 1" F	G 1" F	G 1" F
CONNECTION SIZE	--	G 6/4" F	G 6/4" F	G 6/4" F	G 6/4" F	G 6/4" F	G 6/4" F
K_{vs} from A to AB	m ³ /h	6.2	6.2	6.2	6.2	6.2	6.2
K_{vs} from B to AB	m ³ /h	4.4	4.4	4.4	4.4	4.4	4.4
WEIGHT	kg	0.81	0.81	0.81	0.81	0.81	0.81
CODE	--	13 095	15 939	13 096	15 940	13 097	15 941

TSV3BMF

Valves for return temperature control, with automatic by-pass balancing

Load valve with automatic by-pass balancing, with 1" M threads on both A and B inlets and a 1" F union nut on the AB outlet. The union nut permits direct connection to a circulation pump with 1" connection size.



Dimensions

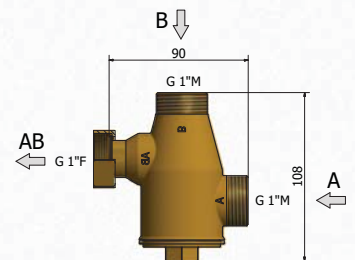

Versions

		TSV3BMF 45	TSV3BMF 55	TSV3BMF 65
OPENING TEMPERATURE	°C	45	55	65
NOMINAL DIAMETER	-	G 1" M	G 1" M	G 1" M
CONNECTION SIZE	--	G 1" F	G 1" F	G 1" F
K_{vs} from A to AB	m ³ /h	8.6	8.6	8.6
K_{vs} from B to AB	m ³ /h	5.1	5.1	5.1
WEIGHT	kg	0.69	0.69	0.69
CODE	--	13 980	13 981	13 982

*50, 60, 70 °C temperatures upon request

■ PROTECTION AGAINST BOILER CORROSION AND FOULING
Load Valves with automatic by-pass balancing



TSV3BM

Valves for return temperature control, with automatic by-pass balancing

Load valve with automatic by-pass balancing and 1" M threads permitting easy connection to copper pipes with union nuts, e.g. when integrated into a boiler.

Dimensions

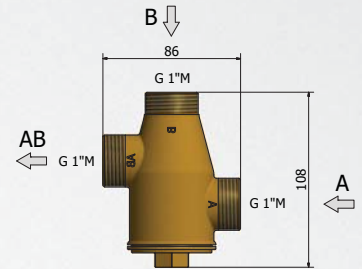

Versions

		TSV3BM 45	TSV3BM 55	TSV3BM 65
OPENING TEMPERATURE	°C	45	55	65
NOMINAL DIAMETER	--	G 1" M	G 1" M	G 1" M
K_{vs} from A to AB	m ³ /h	9.8	9.8	9.8
K_{vs} from B to AB	m ³ /h	5.3	5.3	5.3
WEIGHT	kg	0.65	0.65	0.65
CODE	--	13 977	13 978	13 979

*50, 60, 70 °C temperatures upon request

PROTECTION AGAINST BOILER CORROSION AND FOULING

Load Valves with automatic by-pass balancing



TSV5B

Valves for return temperature control, with automatic by-pass balancing

TSV B load valves mix cool return water from a heating system or thermal store with hot water from a boiler flow, **keeping boiler return water** (i.e. its heat transfer surfaces) at a temperature that will **not allow condensation to occur**. The boiler then works with higher efficiency and its service life is extended.

The valves feature automatic by-pass balancing. The exact control prevents boiler overheating and keeps a steady flow rate through a boiler under any temperature if the system is properly designed. When restricting the flow through one port, it opens the other one simultaneously.

Dimensions

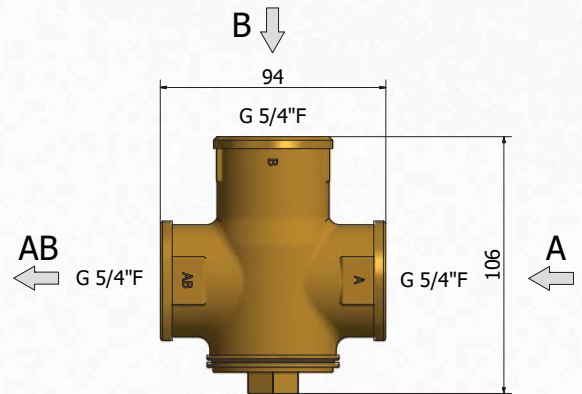

Versions

		TSV5B 45	TSV5B 50	TSV5B 55	TSV5B 60	TSV5B 65	TSV5B 70
OPENING TEMPERATURE	°C	45	50	55	60	65	70
NOMINAL DIAMETER	-	DN32	DN32	DN32	DN32	DN32	DN32
CONNECTION SIZE	--	G 5/4" F	G 5/4" F	G 5/4" F	G 5/4" F	G 5/4" F	G 5/4" F
K_{vs} from A to AB	m ³ /h	7.0	7.0	7.0	7.0	7.0	7.0
K_{vs} from B to AB	m ³ /h	4.9	4.9	4.9	4.9	4.9	4.9
WEIGHT	kg	0.87	0.87	0.87	0.87	0.87	0.87
CODE	--	11 806	15 520	11 807	15 521	11 808	15 522

Connection in a system

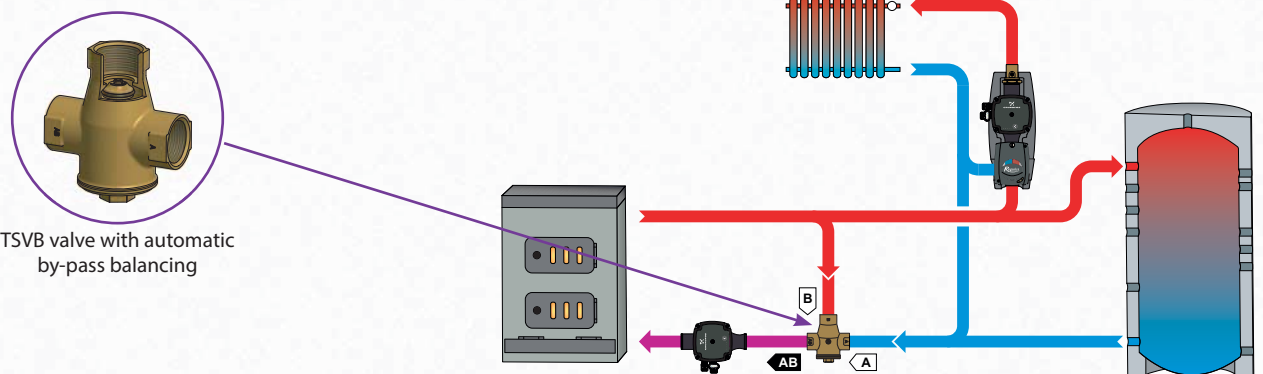

PROTECTION AGAINST BOILER CORROSION AND FOULING

Load Valves with manual by-pass balancing



TSV5

Valves for return temperature control, with manual by-pass balancing

TSV load valves with manual by-pass adjustment mix cool return water from a heating system or thermal store with hot water from a boiler flow, **keeping boiler return water** (i.e. its heat transfer surfaces) at a temperature that will **not allow condensation to occur**. The boiler then works with higher efficiency and its service life is extended.

Balancing of TSV5 valves needs to be performed manually using a balancing valve in the by-pass pipe. Boiler manufacturer ATMOS recommends that these models of TSV valves are used with his boilers.

Dimensions

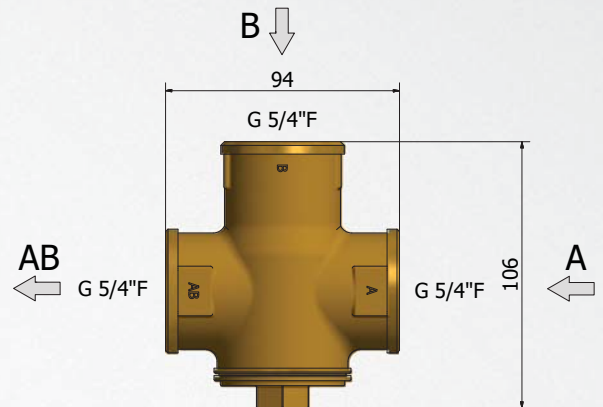

Versions

	TSV5 65	TSV5 72	TSV5 77
OPENING TEMPERATURE	65 °C	72 °C	77 °C
NOMINAL DIAMETER		DN32	
CONNECTION SIZE		G 5/4" F	
MAX. WORKING PRESSURE		6 bar	
K_{vs} from A to AB		7.0 m ³ /h	
K_{vs} from B to AB		11.5 m ³ /h	
WEIGHT		0.85 kg	
CODE	11 804	15 533	11 836

Connection in a system

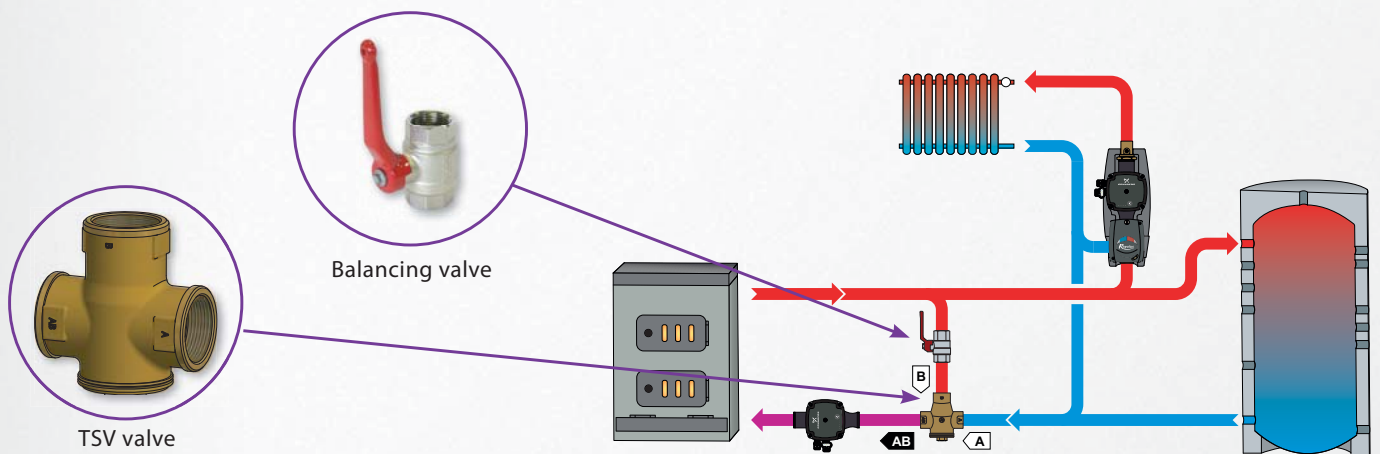

PROTECTION AGAINST BOILER CORROSION AND FOULING

Load Valves with automatic by-pass balancing



TSV6B

Valves for return temperature control, with automatic by-pass balancing

TSV B load valves mix cool return water from a heating system or thermal store with hot water from a boiler flow, **keeping boiler return water** (i.e. its heat transfer surfaces) at a temperature that **will not allow condensation to occur**. The boiler then works with higher efficiency and its service life is extended.

The valves feature automatic by-pass balancing. The exact control prevents boiler overheating and keeps a steady flow rate through a boiler under any temperature if the system is properly designed. When restricting the flow through one port, it opens the other one simultaneously.

Dimensions

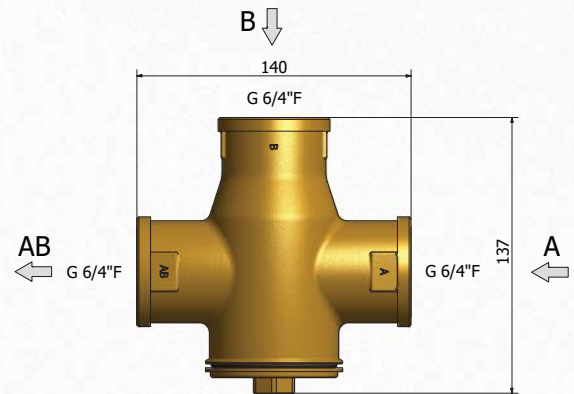

Versions

		TSV6B 45	TSV6B 55	TSV6B 65
OPENING TEMPERATURE	°C	45	55	65
NOMINAL DIAMETER	-	DN40	DN40	DN40
CONNECTION SIZE	--	G 6/4" F	G 6/4" F	G 6/4" F
K_{vs} from A to AB	m ³ /h	13.3	13.3	13.3
K_{vs} from B to AB	m ³ /h	9.6	9.6	9.6
WEIGHT	kg	1.7	1.7	1.7
CODE	--	12 974	12 975	12 976

Connection in a system

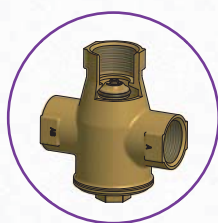

TSVB valve with automatic by-pass balancing

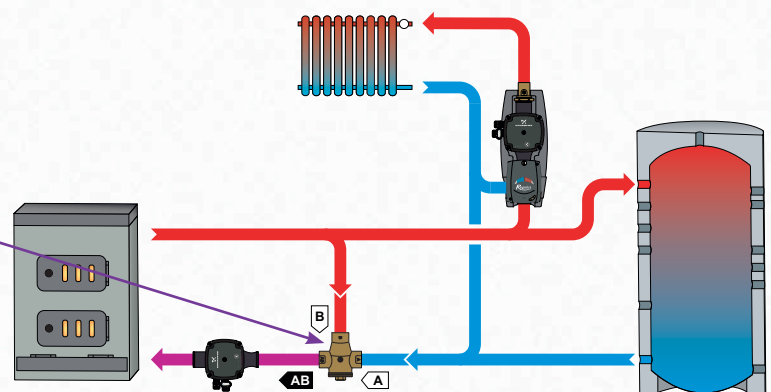

PROTECTION AGAINST BOILER CORROSION AND FOULING

Load Valves with manual by-pass balancing



TSV6

Valves for return temperature control, with manual by-pass balancing

TSV load valves with manual by-pass adjustment mix cool return water from a heating system or thermal store with hot water from a boiler flow, **keeping boiler return water** (i.e. its heat transfer surfaces) at a temperature that will **not allow condensation to occur**. The boiler then works with higher efficiency and its service life is extended.

Balancing of TSV6 valves needs to be performed manually using a balancing valve in the by-pass pipe. Boiler manufacturer ATMOS recommends that these models of TSV valves are used with his boilers.

Dimensions

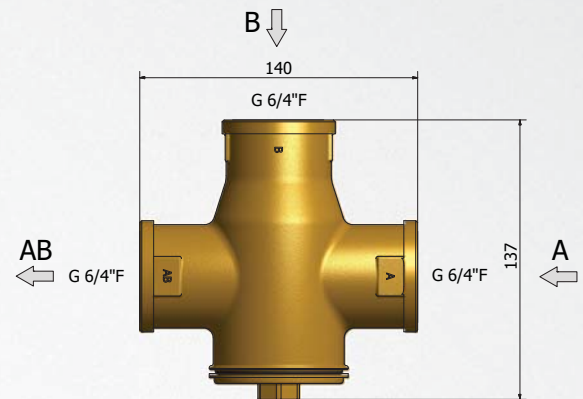

Versions

	TSV6 65	TSV6 72
OPENING TEMPERATURE	65 °C	72 °C
NOMINAL DIAMETER	DN40	DN40
CONNECTION SIZE	G 6/4" F	G 6/4" F
MAX. WORKING PRESSURE	6 bar	6 bar
K_{vs} from A to AB	13.3 m ³ /h	13.3 m ³ /h
K_{vs} from B to AB	19.8 m ³ /h	19.8 m ³ /h
WEIGHT	1.6 kg	1.6 kg
CODE	11 821	16 060

Connection in a system

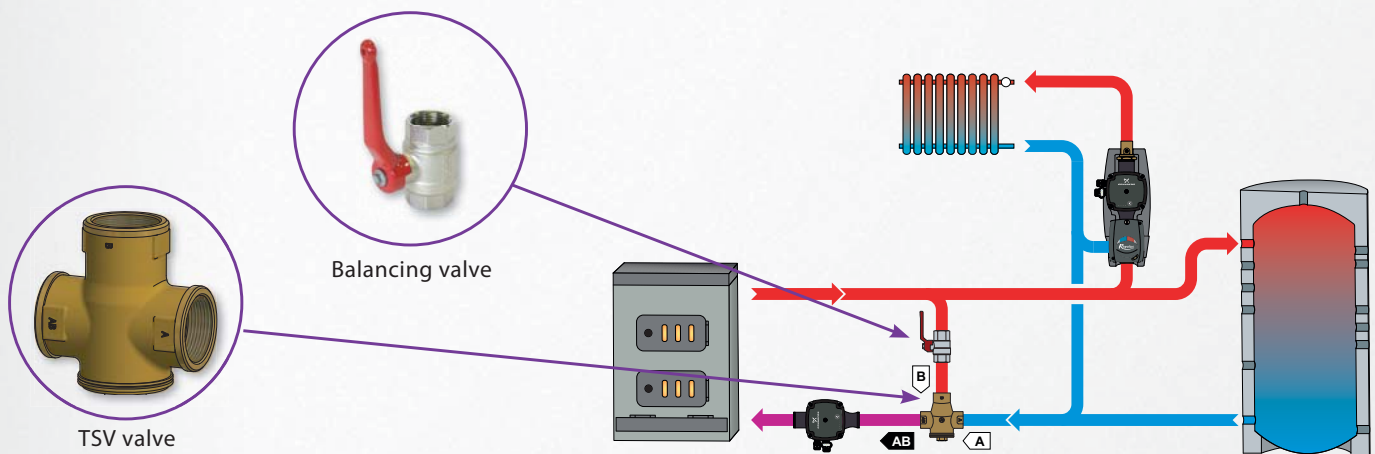

PROTECTION AGAINST BOILER CORROSION AND FOULING

Thermostatic Valves



TSV8B

Valves for return temperature control, with automatic by-pass balancing

TSV B load valves mix cool return water from a heating system or thermal store with hot water from a boiler flow, **keeping boiler return water** (i.e. its heat transfer surfaces) at a temperature that **will not allow condensation to occur**. The boiler then works with higher efficiency and its service life is extended.

The valves feature automatic by-pass balancing. The exact control prevents boiler overheating and keeps a steady flow rate through a boiler under any temperature if the system is properly designed. When restricting the flow through one port, it opens the other one simultaneously.

Dimensions

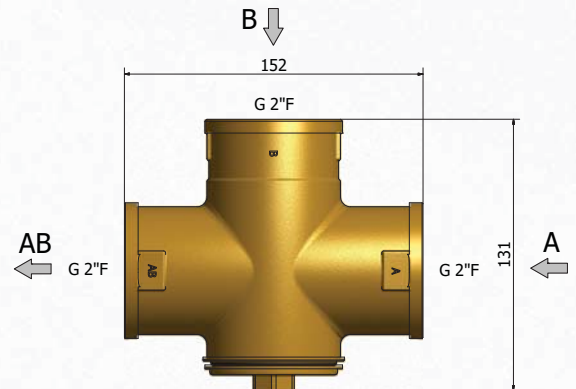

Versions

		TSV8B 45	TSV8B 55	TSV8B 65
OPENING TEMPERATURE	°C	45	55	65
NOMINAL DIAMETER	-	DN50	DN50	DN50
CONNECTION SIZE	--	G 2" F	G 2" F	G 2" F
K_{vs} from A to AB	m ³ /h	15.8	15.8	15.8
K_{vs} from B to AB	m ³ /h	11.1	11.1	11.1
WEIGHT	kg	1.85	1.85	1.85
CODE	--	12 977	12 978	12 979

Connection in a system

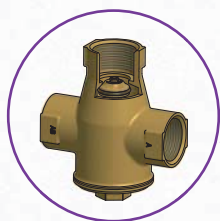

TSVB valve with automatic by-pass balancing

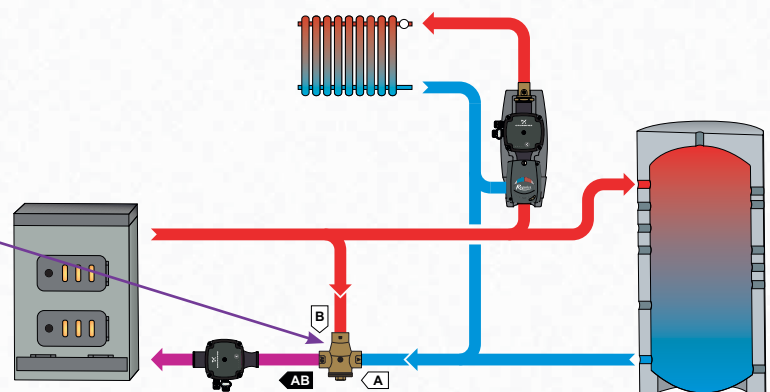

PROTECTION AGAINST BOILER CORROSION AND FOULING

Thermostatic Valves



TSV8

Valves for return temperature control, with manual by-pass balancing

TSV load valves with manual by-pass adjustment mix cool return water from a heating system or thermal store with hot water from a boiler flow, **keeping boiler return water** (i.e. its heat transfer surfaces) at a temperature that will **not allow condensation to occur**. The boiler then works with higher efficiency and its service life is extended.

Balancing of TSV8 valves needs to be performed manually using a balancing valve in the by-pass pipe. Boiler manufacturer ATMOS recommends that these models of TSV valves are used with his boilers.

Dimensions

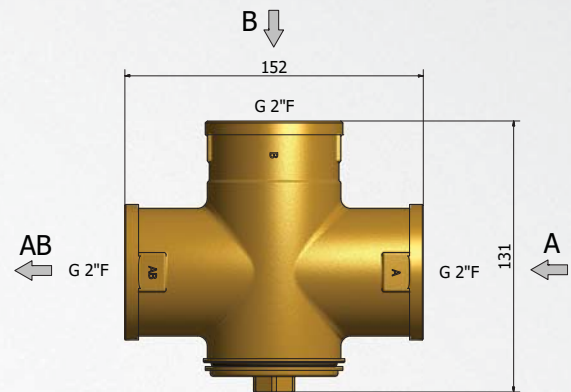

Versions

	TSV8 65	TSV8 72
OPENING TEMPERATURE	65 °C	72 °C
NOMINAL DIAMETER	DN50	DN50
CONNECTION SIZE	G 2" F	G 2" F
MAX. WORKING PRESSURE	6 bar	6 bar
K_{vs} from A to AB	15.8 m ³ /h	15.8 m ³ /h
K_{vs} from B to AB	27.4 m ³ /h	27.4 m ³ /h
WEIGHT	1.75 kg	1.75 kg
CODE	11 819	16 061

Connection in a system

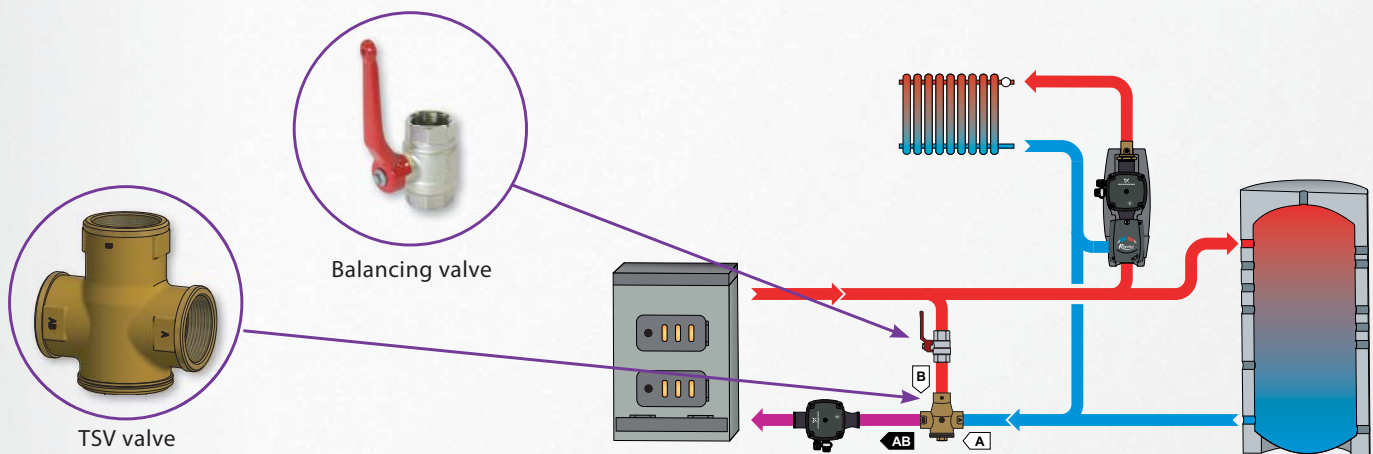

PROTECTION AGAINST BOILER CORROSION AND FOULING

Insulated Load Units



REGOMAT E G

Load unit

Load unit for solid-fuel boilers and fireplaces that prevents **low-temperature corrosion and boiler fouling by keeping a boiler (fireplace) inlet temperature** through a thermostatic valve.

REGOMAT E G load unit comes in a left version (outlet to boiler is on its left side), and can be easily modified to a right version (outlet to boiler on its right side) during installation. Its installation position can be either horizontal or vertical.

It consists of a UPM3 high efficiency circulation pump incl. connection cables, enabling PWM control, a ball shut-off valve for the pump, thermometer, insulation and TSV3BF valve with a thermostatic element of 45 to 70 °C opening temperature.

Technical Data

FLUID WORKING TEMPERATURE	2 - 95 °C
POWER SUPPLY	230 V, 50 Hz
IP RATING	IP44
TOTAL WEIGHT	3.25 kg
CONNECTION	3 x G1" F
K_{vs} from A to AB	6.2 m ³ /h
K_{vs} from B to AB	4.4 m ³ /h
MAX. HEAD	7 m
PUMP OPERATING POINT at Δt 20 K	1.8 m ³ /h flow rate 4.9 m head

For circulation pump performance curves see pages 34, 35.

Prevention of low-temperature corrosion of boilers.
Installation possible with A inlet from either right or left side.
Minimum heat loss thanks to thermal insulation.

Versions

Name	Code	Valve opening temp.	Recommended max. boiler output
REGOMAT E 45 G	14 925	45 °C	48 kW
REGOMAT E 50 G	15 910	50 °C	44 kW
REGOMAT E 55 G	14 926	55 °C	37 kW
REGOMAT E 60 G	15 911	60 °C	33 kW
REGOMAT E 65 G	14 927	65 °C	27 kW
REGOMAT E 70 G	15 912	70 °C	23 kW

Connection in a system

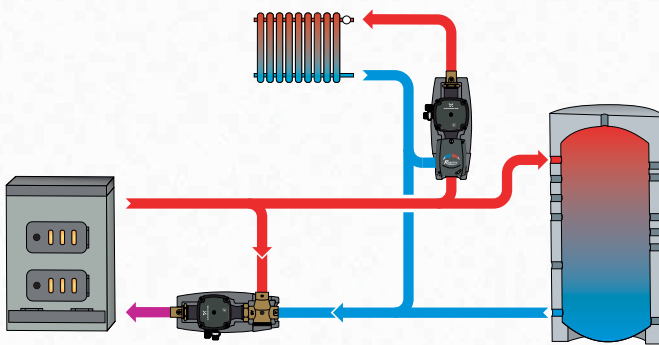

Dimensions

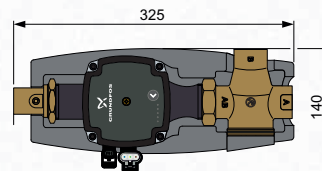

PROTECTION AGAINST BOILER CORROSION AND FOULING

Insulated Load Units



REGOMAT E W

Load unit

Load unit for solid-fuel boilers and fireplaces that prevents **low-temperature corrosion and boiler fouling by keeping a boiler (fireplace) inlet temperature** through a load valve.

REGOMAT E W load unit comes in a left version (outlet to boiler is on its left side), and can be easily modified to a right version (outlet to boiler on its right side) during installation. Its installation position can be either horizontal or vertical.

It consists of a Wilo Yonos Para high efficiency circulation pump incl. connection cable, a ball shut-off valve for the pump, thermometer, insulation and TSV3BF valve with a thermostatic element of 45 to 70 °C opening temperature.

Technical Data

FLUID WORKING TEMPERATURE	2 - 95 °C
POWER SUPPLY	230 V, 50 Hz
IP RATING	IP44
TOTAL WEIGHT	3.26 kg
CONNECTION	3 x G1" F
K_{vs} from A to AB	6.2 m ³ /h
K_{vs} from B to AB	4.4 m ³ /h
MAX. HEAD	6.2 m
PUMP OPERATING POINT at Δt 20 K	1.7 m ³ /h flow rate 4.6 m head

For circulation pump performance curves see pages 34, 35.

Prevention of low-temperature corrosion of boilers.
Installation possible with A inlet from either right or left side.
Minimum heat loss thanks to thermal insulation.

Versions

Name	Code	Valve opening temp.	Recommended max. boiler output
REGOMAT E 45 W	15 867	45 °C	45 kW
REGOMAT E 50 W	15 904	50 °C	42 kW
REGOMAT E 55 W	15 868	55 °C	36 kW
REGOMAT E 60 W	15 905	60 °C	32 kW
REGOMAT E 65 W	15 869	65 °C	26 kW
REGOMAT E 70 W	15 906	70 °C	22 kW

Connection in a system

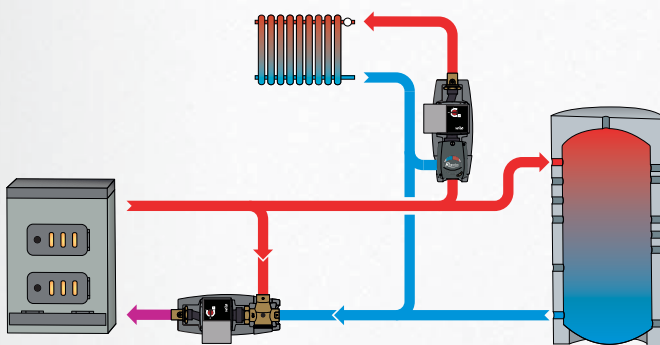

Dimensions

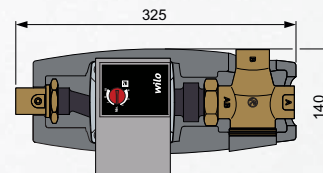

PROTECTION AGAINST BOILER CORROSION AND FOULING

Insulated Load Units



REGOMAT E W 5/4

Load unit

Load unit for solid-fuel boilers and fireplaces that prevents **low-temperature corrosion and boiler fouling by keeping a boiler (fireplace) inlet temperature** through a load valve.

REGOMAT E W 5/4 load unit comes in a left version (outlet to boiler is on its left side), and can be easily modified to a right version (outlet to boiler on its right side) during installation. Its installation position can be either horizontal or vertical.

It consists of a Wilo Yonos Para high efficiency circulation pump incl. connection cable, thermometer, insulation and TSV5B valve with a thermostatic element of 45 to 70 °C opening temperature.

Technical Data

FLUID WORKING TEMPERATURE	2 - 95 °C
POWER SUPPLY	230 V, 50 Hz
IP RATING	IP44
TOTAL WEIGHT	3.27 kg
CONNECTION	3 x G5/4" F
K_{vs} from A to AB	7.0 m ³ /h
K_{vs} from B to AB	4.9 m ³ /h
MAX. HEAD	7.6 m
PUMP OPERATING POINT at Δt 20 K	2.7 m ³ /h flow rate 4.9 m head

For circulation pump performance curves see pages 34, 35.

Prevention of low-temperature corrosion of boilers.
Installation possible with A inlet from either right or left side.
Minimum heat loss thanks to thermal insulation.

Versions

Name	Code	Valve opening temp.	Recommended max. boiler output
REGOMAT E 45 W 5/4	15 789	45 °C	72 kW
REGOMAT E 50 W 5/4	15 913	50 °C	66 kW
REGOMAT E 55 W 5/4	15 790	55 °C	57 kW
REGOMAT E 60 W 5/4	15 914	60 °C	50 kW
REGOMAT E 65 W 5/4	15 791	65 °C	41 kW
REGOMAT E 70 W 5/4	15 915	70 °C	35 kW

Connection in a system

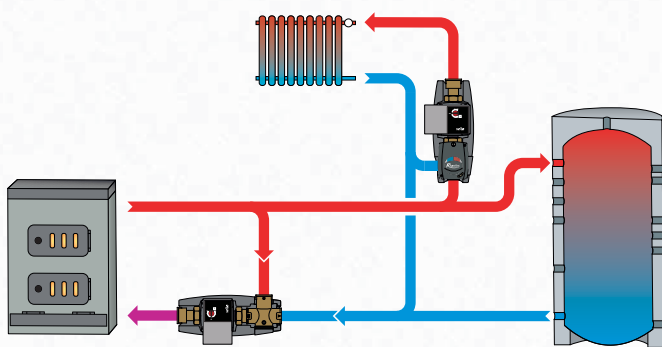

Dimensions

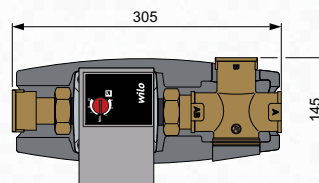

PROTECTION AGAINST BOILER CORROSION AND FOULING

Insulated Load Units



REGOMAT EA W

Load unit with manual bypass balancing

Load unit for solid-fuel boilers and fireplaces that prevents **low-temperature corrosion and boiler fouling by keeping a boiler (fireplace) inlet temperature** through a load valve.

REGOMAT EA W load unit comes in a left version (outlet to boiler is on its left side), and can be easily modified to a right version (outlet to boiler on its right side) during installation. Its installation position can be either horizontal or vertical.

It consists of a Wilo Yonos Para 25/6 high efficiency circulation pump incl. connection cable, a ball shut-off valve for the pump, thermometer, insulation and TSV3 valve with a thermostatic element of 65 or 72 °C opening temperature. **Balancing of TSV valve needs to be performed manually using a balancing valve in the by-pass pipe.**

Boiler manufacturer ATMOS recommends that these models of load units are used with his boilers.

Technical Data

FLUID WORKING TEMPERATURE	2 - 95 °C
POWER SUPPLY	230 V, 50 Hz
IP RATING	IP44
TOTAL WEIGHT	3.25 kg
CONNECTION	3x 1" F
K_{vs} from A to AB	6.2 m ³ /h
K_{vs} from B to AB	10.1 m ³ /h
MAX. HEAD	6.2 m
PUMP OPERATING POINT at Δt 20 K	2.0 m ³ /h flow rate 3.9 m head

For circulation pump performance curves see pages 34, 35.

Prevention of low-temperature corrosion of boilers.
Installation possible with A inlet from either right or left side.
Minimum heat loss thanks to thermal insulation.

Versions

Name	Code	Valve opening temp.	Recommended max. boiler output
REGOMAT EA 65 W	16 036	65 °C	30 kW
REGOMAT EA 72 W	16 031	72 °C	30 kW

* at Δt of 20 K and fully open balancing valve

Connection in a system

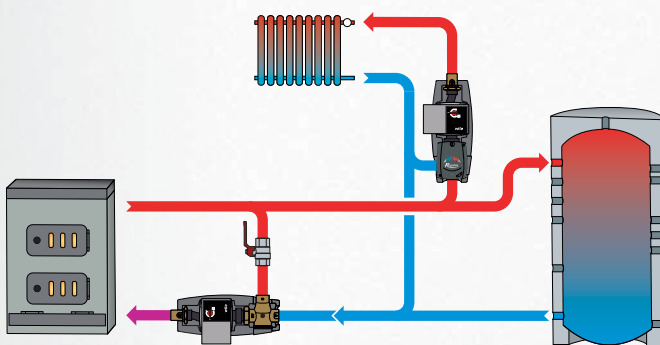

Dimensions

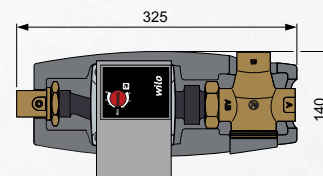

PROTECTION AGAINST BOILER CORROSION AND FOULING

Insulated Load Units



REGOMAT EA W 5/4

Load unit with manual by-pass balancing

Load unit for solid-fuel boilers and fireplaces that prevents **low-temperature corrosion and boiler fouling by keeping a boiler (fireplace) inlet temperature** through a load valve.

REGOMAT EA W 5/4 load unit comes in a left version (outlet to boiler is on its left side), and can be easily modified to a right version (outlet to boiler on its right side) during installation. Its installation position can be either horizontal or vertical.

It consists of a Wilo Yonos Para 25/7.5 high efficiency circulation pump incl. connection cable, thermometer, insulation and TSV5 valve with a thermostatic element of 65 or 72 °C opening temperature. **Balancing of TSV valve needs to be performed manually using a balancing valve in the by-pass pipe.**

Boiler manufacturer ATMOS recommends that these models of load units are used with his boilers.

Technical Data

FLUID WORKING TEMPERATURE	2 - 95 °C
POWER SUPPLY	230 V, 50 Hz
IP RATING	IP44
TOTAL WEIGHT	3.25 kg
CONNECTION	3x 5/4" F
K _{vs} from A to AB	7.0 m ³ /h
K _{vs} from B to AB	11.5 m ³ /h
MAX. HEAD	7.6 m
PUMP OPERATING POINT at Δt 20 K	3.3 m ³ /h flow rate 3.8 m head

For circulation pump performance curves see pages 34, 35.

**Prevention of low-temperature corrosion of boilers.
Installation possible with A inlet from either right or left side.
Minimum heat loss thanks to thermal insulation.**

Versions

Name	Code	Valve opening temp.	Recommended max. boiler output
REGOMAT EA 65 W 5/4	16 037	65 °C	50 kW
REGOMAT EA 72 W 5/4	16 032	72 °C	50 kW

* at Δt of 20 K and fully open balancing valve

Connection in a system

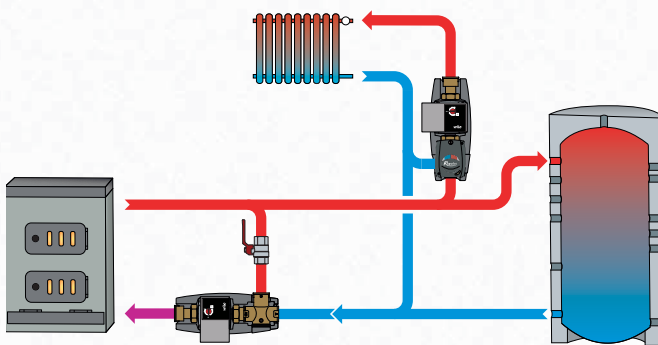

Dimensions

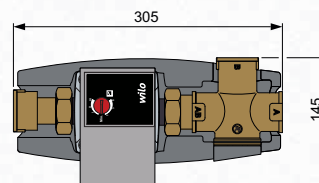

PROTECTION AGAINST BOILER CORROSION AND FOULING

Accessories for REGOMAT Load Units



BP REGOMAT

By-pass with floating non-return valve

Regomat load units can be amended with a by-pass with a floating non-return valve.

In case of a power failure or a broken circulation pump the boiler will cool down into the thermal store via gravity circulation through the by-pass with non-return valve.

Versions

Name			Code
By-pass with a non-return valve for Regomat with 1" connection			16 126
By-pass with a non-return valve for Regomat with 5/4" connection			16 139

Connection in a system

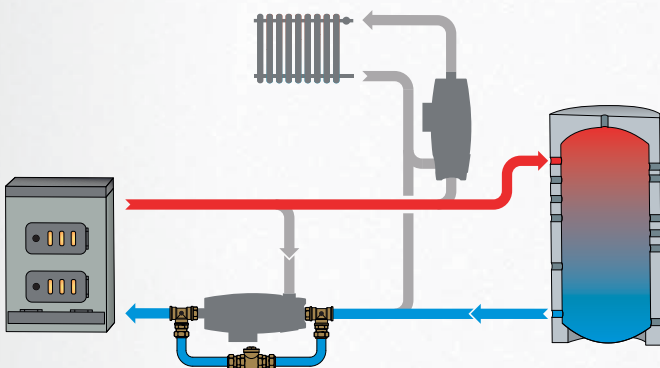

PROTECTION AGAINST BOILER CORROSION AND FOULING

Insulated Load Units



CSE MIX

Load unit with electric actuated mixing

Load unit designed to control return line of solid-fuel boilers or to control outlet to a mixed heating circuit using an external controller.

The load unit consists of:

- Circulation pump
- Load valve
- Load valve actuator
- Neat insulation for low heat loss

Technical Data

FLUID WORKING TEMPERATURE	5 - 110 °C
LOAD VALVE ACTUATOR	3-point control, 120 s, 5 Nm
POWER SUPPLY	230 V, 50 Hz
IP RATING	IP44

Versions

	CSE MIX G 1M	CSE MIX W 1M	CSE MIX W 1F	CSE MIX W 5/4F
Connection	1" (2x M, 1x F)	1" (2x M, 1x F)	1" (3x F)	5/4" (3x F)
Pump	UPM3	YP 25/6	YP 25/6	YP 25/7,5
Max. head	7 m	6.2 m	6.2 m	7.6 m
K _{vs} of the valve	6.3 m ³ /h	6.3 m ³ /h	12 m ³ /h	15 m ³ /h
Code	15 208	16 082	16 219	16 215

Connection in a system

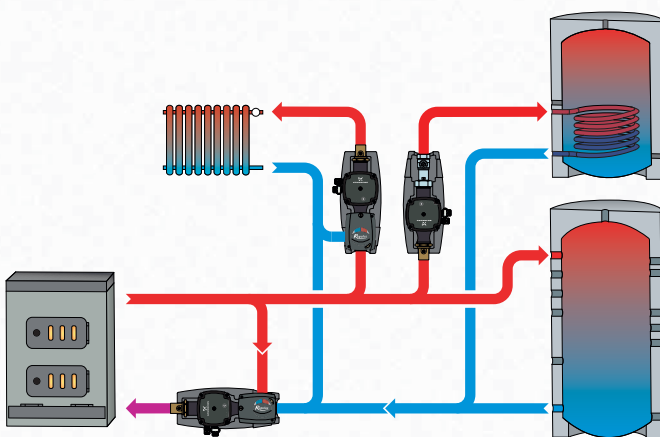

Dimensions

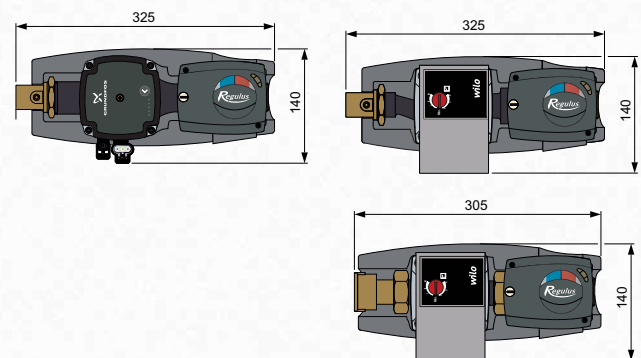

Accessories

Connection fittings for valve with outer thread (for units code 15 208 and 16 082)

Name	Description	Code
Pipe fitting 1" FFU	Union nut 1" - 1" F	15 694
Pipe fitting 1" MFU	Union nut 1" - 1" M	15 695

PROTECTION AGAINST BOILER CORROSION AND FOULING

Insulated Load Units



CSE MIX FIX

Load unit with electronic controlled mixing

Load unit designed to control return line of solid-fuel boilers or to control outlet to a mixed heating circuit to a fixed temperature, adjustable directly on the actuator, between 0 and 99°C.

The load unit consists of:

- Circulation pump
- Load valve
- Load valve actuator with electronics
- Pt1000 temperature sensors – 2 pieces
- Neat insulation for low heat loss

Technical Data

FLUID WORKING TEMPERATURE	5 - 110 °C
LOAD VALVE ACTUATOR	control to a fixed temp., 120 s, 6 Nm
POWER SUPPLY	230 V, 50 Hz
IP RATING	IP44

Versions

	CSE MIX FIX G 1M	CSE MIX FIX W 1M	CSE MIX FIX W 1F	CSE MIX FIX W 5/4F
Connection	1" (2x M, 1x F)	1" (2x M, 1x F)	1" (3x F)	5/4" (3x F)
Pump	UPM3	YP 25/6	YP 25/6	YP 25/7,5
Max. head	7 m	6.2 m	6.2 m	7.6 m
K _{vs} of the valve	6.3 m ³ /h	6.3 m ³ /h	12 m ³ /h	15 m ³ /h
Code	15 333	16 083	16 220	16 216

Connection in a system

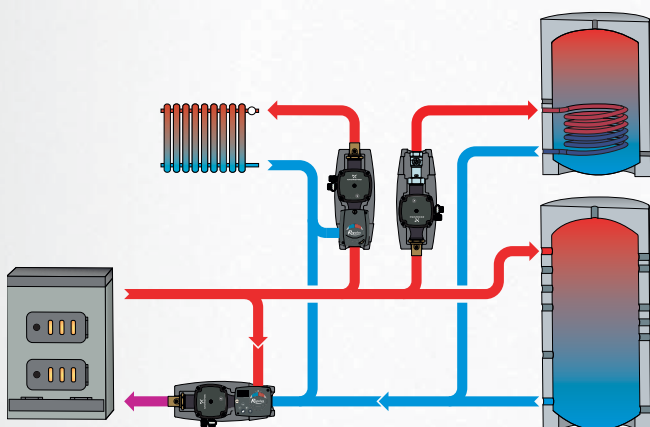

Dimensions

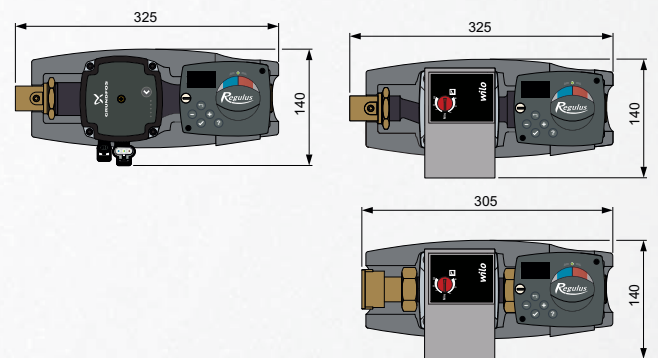

Accessories

Connection fittings for valve with outer thread
(for units code 15 208 and 16 082)

Name	Description	Code
Pipe fitting 1" FFU	Union nut 1" - 1" F	15 694
Pipe fitting 1" MFU	Union nut 1" - 1" M	15 695

PROTECTION AGAINST BOILER CORROSION AND FOULING

Insulated Load Units

Grundfos UPM3 Circulation pump

UPM3 circulation pump is included in REGOMAT E G, CSE MIX G and CSE MIX FIX G load units.

Circulation pump performance curves

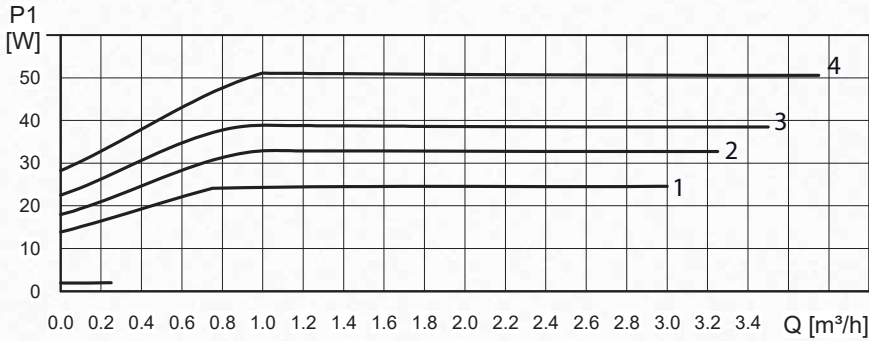
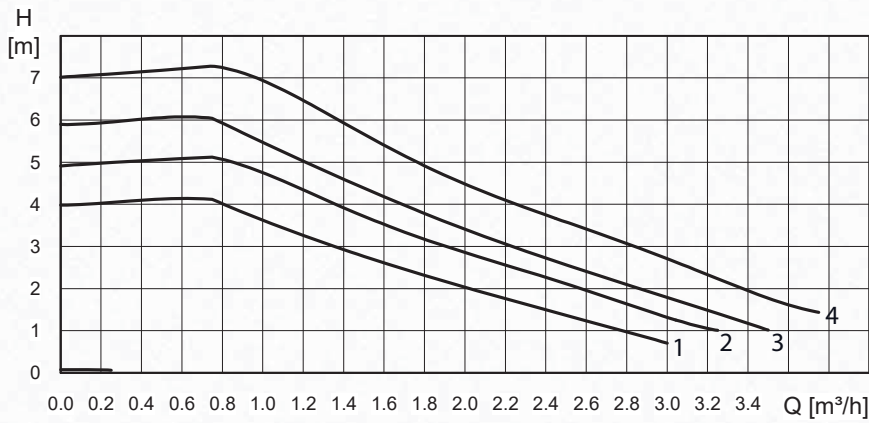

PROTECTION AGAINST BOILER CORROSION AND FOULING

Insulated Load Units

Wilо Yonos Para Circulation pump

Yonos Para 25/6

Wilо Yonos Para 25/6 circulation pump is included in REGO-MAT E W, CSE MIX W and CSE MIX FIX W load units.

Circulation pump performance curves at constant speed:

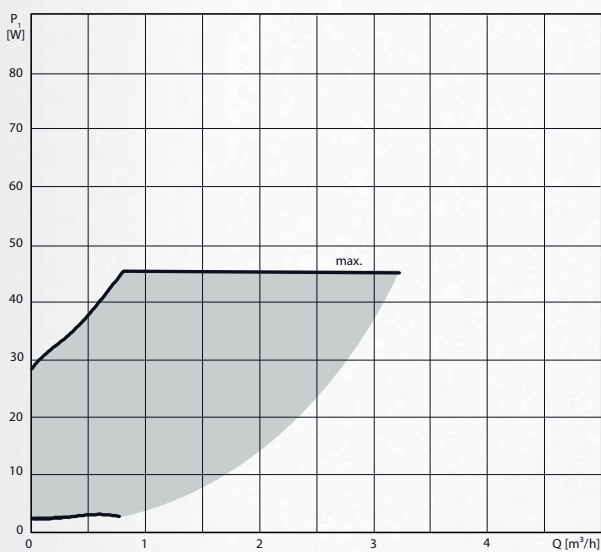
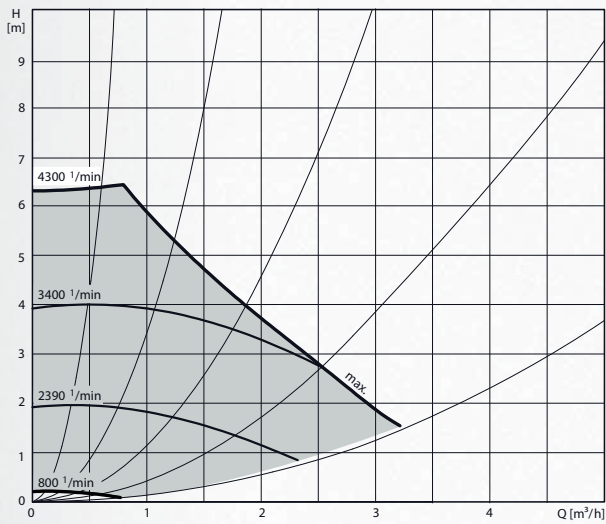

Yonos Para 25/7,5

Wilо Yonos Para 25/7.5 circulation pump is included in REGOMAT E W 5/4, CSE MIX W 5/4 and CSE MIX FIX W 5/4 load units.

Circulation pump performance curves at constant speed:

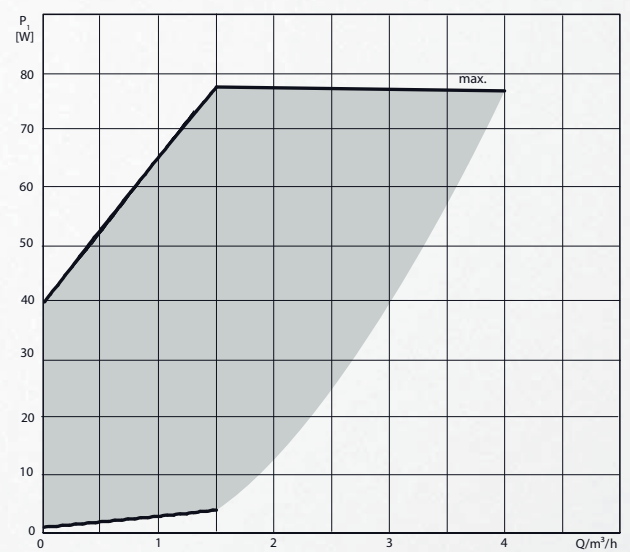
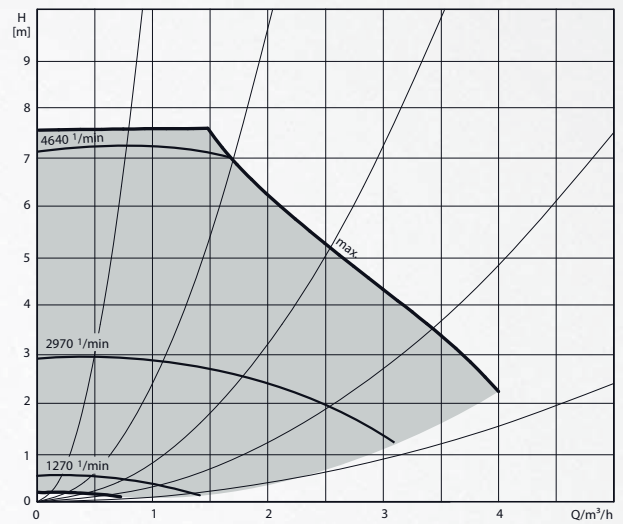



RT4 Thermostatic draft regulator

Thermostatic draft regulator for solid fuel boilers designed to control boiler output by opening or throttling a combustion air damper. The boiler output is modified in such a way that the working fluid temperature (heating water, anti-freeze fluid, heat transfer oil) at the boiler outlet reaches the temperature set by the knob.

The regulator can be installed vertically or horizontally. Its working position (orientation) shall correspond to the picture showing working positions of the RT4 regulator.

Dimensions

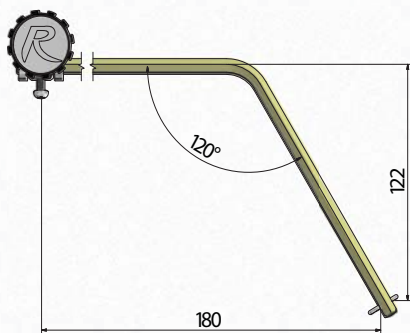
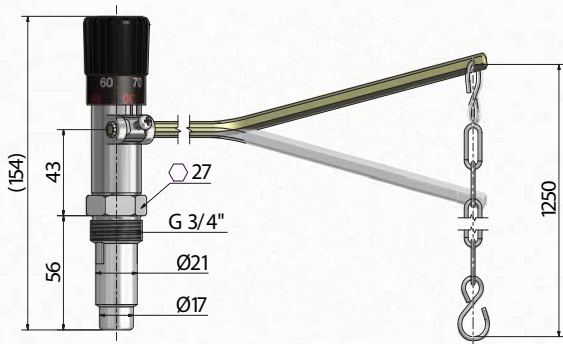

Technical Data

CONNECTION SIZE	G 3/4" M
NOMINAL PRESSURE	PN 6
MAX. WORKING PRESSURE	0.6 MPa
MAX. FLUID WORKING TEMPERATURE	120 °C
CONTROL RANGE OF FLUID TEMPERATURE	30 – 90 °C
MAX. AMBIENT TEMPERATURE	60 °C
CHAIN LOAD	100 – 1 000 g
WEIGHT	420 g
CODE	13 878

Advantages of RT4 draft regulator:

- Higher control power
- Resistance to dusty environment
- Its design permits disassembly
- Nickel plated sheath

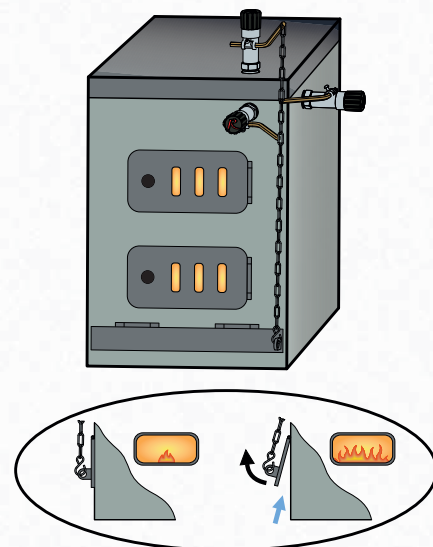

Working positions of RT4 regulator.

Thanks to the many versions and many working positions shown in the fig., the regulator can be easily mounted on any current boiler.

Modified variants

RT4T differs in the sheath shape, RT4L and S were developed from the basic RT4 model but they differ in the lever shape.

RT4T - for boilers with a thicker mantle - Code: 14 138

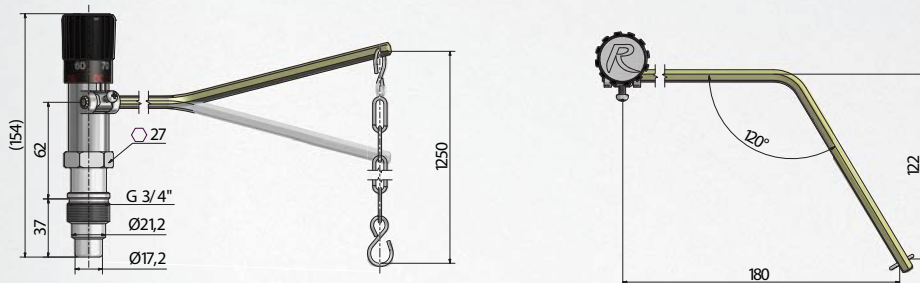

RT4L - with a longer lever - Code: 14 743

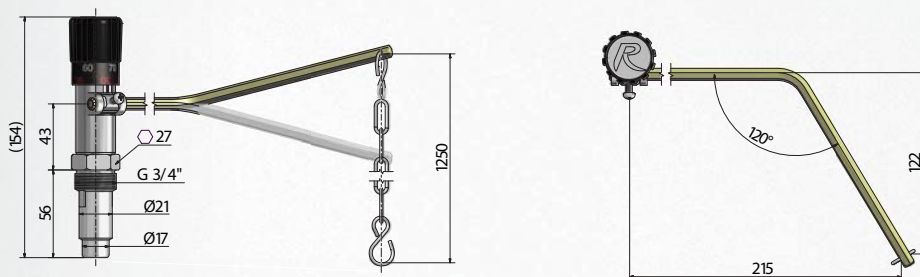

RT4S - with a right-angled lever, 313 mm distance - Code: 14 716

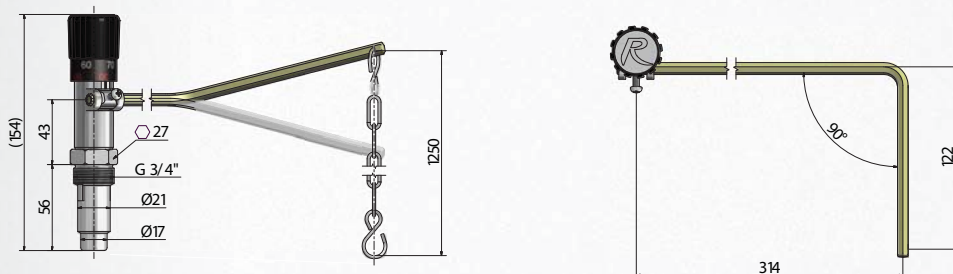

Utility model granted



BOILER OUTPUT CONTROL



RT3E Thermostatic draft regulator, electric operated

Electric controlled draft regulator works like RT4, moreover it permits reducing boiler flow temperature on an electric signal. Both flow temperature and heat output can be controlled by a room thermostat or another electronic controller.

It is fitted with a 3m silicone cable.

When energized with 12V tension, the regulator will reduce the boiler flow temperature.

When not energized, it keeps the temperature at the value set by the knob.

The regulator can be also controlled continuously by 0-12V.

It is supplied either separately or as a kit containing a 12V power supply and either a TP546 mechanical thermostat or a TP07 electronic programmable thermostat.

Dimensions

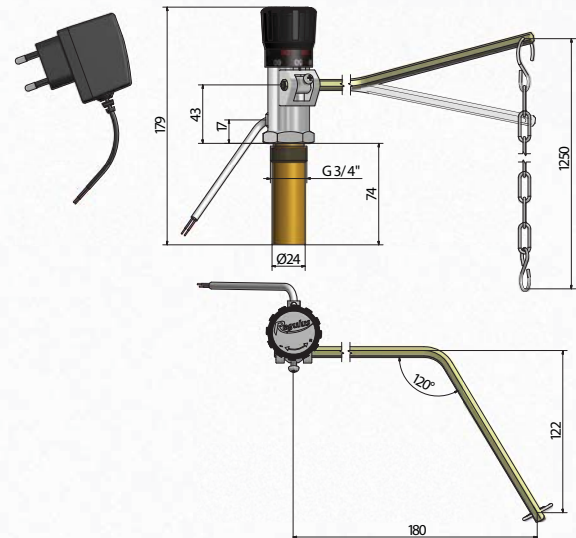

Kits with a thermostat

RT3E - TP07

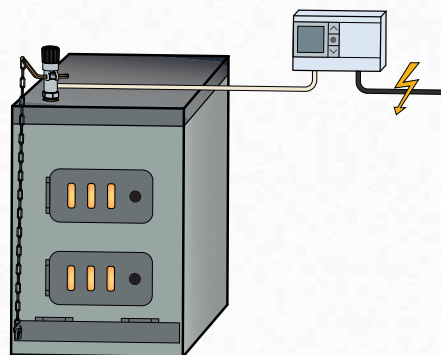

RT3E Regulator is protected by a patent.

RT3E - TP546

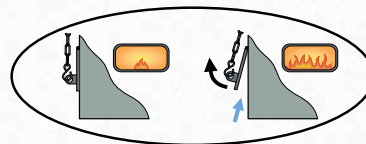

Version	RT3E	RT3E+TP07	RT3E+TP546
Code	7 191	9 138	9 139



