

Installation & Use Instructions

JBV1 Thermostatic Recooling One-way Valve



Use

This thermostatic recooling one-way valve is designed to protect central-heating heat sources against overheating. The valve in its brass body is controlled by a thermostatic element. When the limit temperature of heating water is reached, the valve opens and lets the cold water from the mains flow in and cool down the heating water in a heat exchanger. Heated cooling water is discharged into the sewer system. As soon as the water temperature drops below the limit, the valve closes.

If the pressure in the mains could be above 6 bar, it is necessary to install a pressure reducer at the inlet of cooling water.

Warning: This valve is NO substitution for a safety valve!

Technical Data

Type:	JBV1
Opening temperature (limit):	97 °C (±2 °C)
Max. temperature:	120 °C
Max. pressure on the boiler side:	4 bar
Max. pressure on the water side:	6 bar
Nominal flow rate at Δp 1 bar:	1.8 m ³ /hour at 110 °C water temperature
Valve to heat source coupling:	G 1/2" outer
Cooling water coupling:	G 3/4" outer

Installation

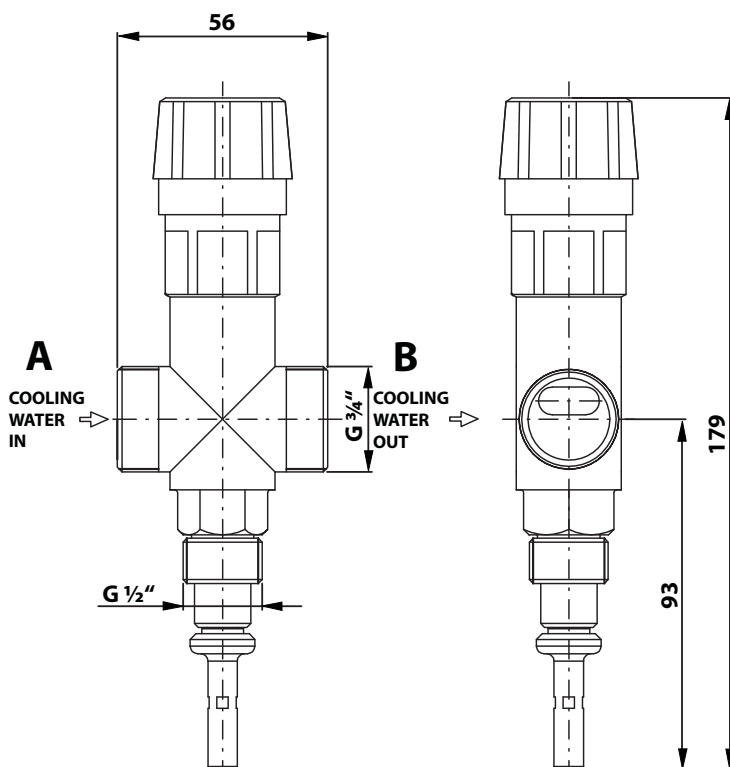

Pic. 1: Dimensions

Installation may be done by qualified personnel only.

On order to ensure flawless operation of this thermostatic recooling one-way valve (JBV1), it is necessary to respect the installation conditions set by the manufacturer of your heating source and the flow directions marked on its body. JBV1 shall be always mounted to a place where the highest temperature in case of overheating is reached (usually in the upper part of the heat source or in the outgoing pipe close to the heat source). When installing JBV1, it is important to check whether the G 1/2" sleeve will ensure total immersion of the valve's thermostatic element.

In order to ensure cooling down the boiler when needed, the cold water inlet shall be connected to pos. „A“ (Pic. 1), as shown in Pic. 3. or 4. A strainer shall be mounted into the cold water pipe to remove mechanical impurities.

If a non-return valve is installed in the inlet piping, the thermostatic valve shall be connected as in Pic. 4.

Min. diameter of the connecting pipes is DN 16.

Always respect instructions from the manufacturer of your heat source, incl. the precise position of the valve and a max. output and type of your heat source.

Regular maintenance

Once a year: turn the head of the thermostatic recooling one-way valve in order to remove possible impurities. Clean the strainer at the cold water inlet.

JBV1 WORKING POSITIONS

The JBV1 thermostatic recooling one-way valve can be mounted vertically as well as horizontally. The valve must not be installed with its head down!

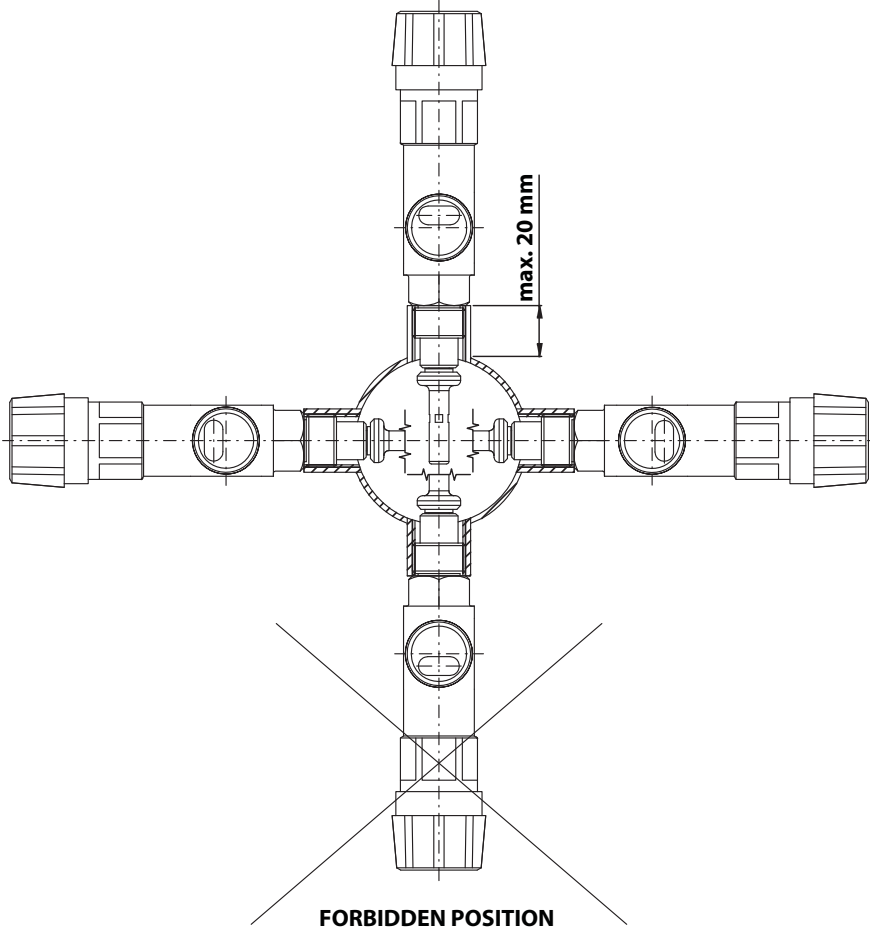

Pic. 2: Piping diagram for JBV1

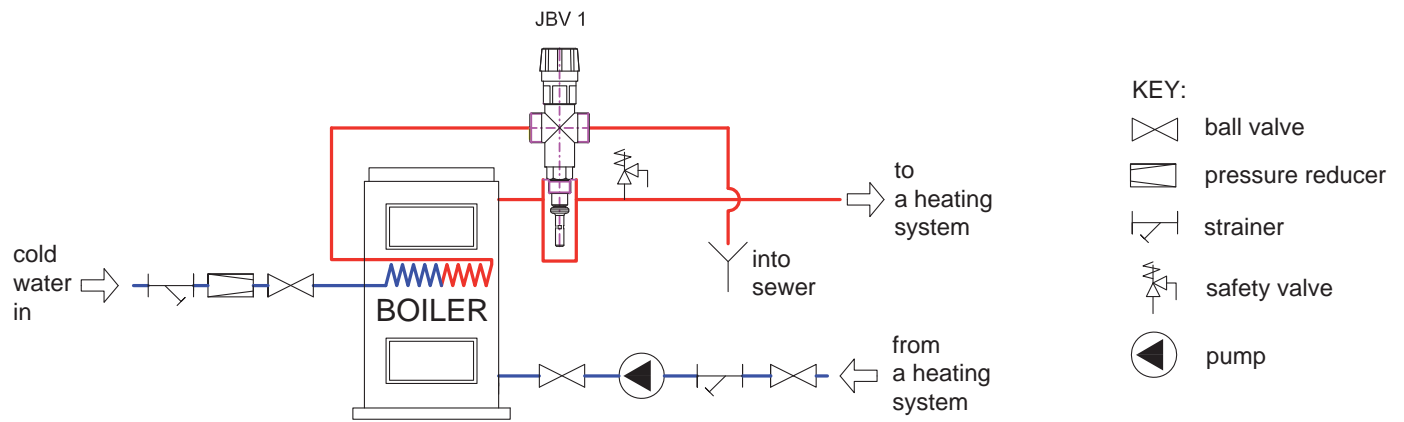

Pic. 3: Piping diagram for JBV1 without a non-return valve used

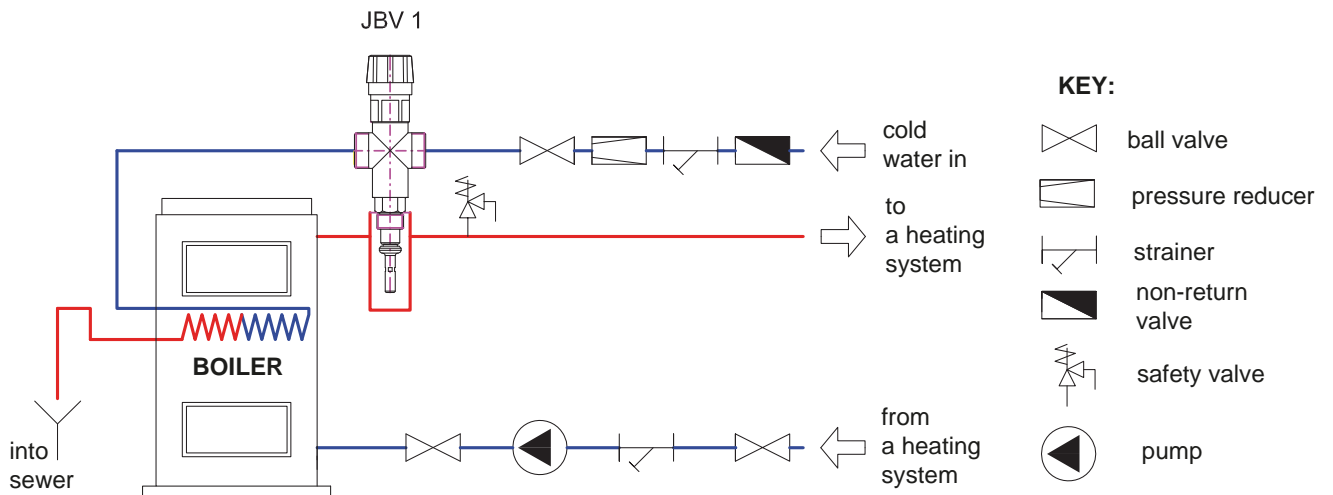

Pic. 4: Piping diagram for JBV1 with a non-return valve used

WARRANTY CERTIFICATE

JBV1 Thermostatic Recooling One-way Valve

WARRANTY CONDITIONS

1. The warranty period is 24 months from the date of purchase of the thermostatic recooling one-way valve or of a boiler, in case the valve is sold as a part of a boiler.
2. When claiming warranty, this Warranty Certificate must be submitted together with the purchase receipt.
3. The warranty is valid only if the technical conditions set by the Manufacturer are respected.
4. The warranty does not cover mechanical damage. The claimed defect must not be caused by tampering, improper installation or mounting position and improper handling, by using the product for other purposes than intended, by installation in improper conditions, and by a natural disaster.
5. Claims shall be settled by your dealer at the address shown below.

Purchase date:.....

Stamp print, signature of the salesman and address of the shop:

03/2013



REGULUS spol. s r.o.
Do Koutů 1897/3
143 00 Praha 4

<http://www.regulus.cz>
E-mail: sales@regulus.cz