Technical Features

- › Direct acting, proportional control valve without or with integrated analog electronic (OBE) with subplate mounting surface acc. to ISO 4401, DIN 24340 (CETOP 05) standards
- › Used for directional and speed control of hydraulic actuators
- › The valve opening and resulting flow rate can be modulated continuously in proportion to the reference signal
- › The valve can be controlled directly by a current control supply unit or by means of the electronic control units to exploit valve performance to the fullest
- › Analog converter card allows fine control of the valve spool position, reducing hysteresis and response time and optimizing the valve performance
- › Five chambers housing design with reduced hydraulic power dependence on fluid viscosity
- › For versions without OBE a wide range of solenoid electrical terminal versions available
- › Wide range of interchangeable spools and manual overrides available
- › The coil is fastened to the core tube with a retaining nut and can be rotated by 360° to suit the available space
- › In the standard version, the valve housing is phosphated and steel parts are zinc-coated for 240 h salt spray protection acc. to ISO 9227
- › Enhanced surface protection for mobile sector available (ISO 9227, 520 h salt spray)

Functional Description
PRM6-10* Versions without on board electronics

The valve can be controlled directly by a current control supply unit or by the external electronic card directly mounted to the electrical terminal (see catalog of EL3E card 9145 and EL6 card 9150). This control card, depending on the number of the controlled solenoids, can be mounted onto either solenoid.

PRM6-10*EK Versions with on board electronics

A control box, which comprises one or two electronic control cards, depending on the number of controlled solenoids, can be mounted onto either solenoid. For models with two solenoids, the solenoid mounted opposite the control box is connected to the box by a DIN connector, a two-lead cable and a bushing.

The connection of the control box with the supply source and with the control signal is implemented by a 4-pin connector of type M12x1. The electric control unit supplies the solenoid with current, which varies with the control signal.

The electronic control unit provides the following adjustment possibilities:

Offset, gain, rise and drop-out time of the ramp generator, frequency (2 frequencies) and amplitude of the dither signal generator.

The correct function of the control unit is signaled by LEDs.

Stabilized voltage +10 V (+5 V for 12 V voltage) is also available to the user.

Using this voltage and a potentiometer $\geq 1k\Omega$ a voltage control signal can be generated.

The electronic control card enables voltage or current control to be used, depending on the position of the switches SW1 to SW3.

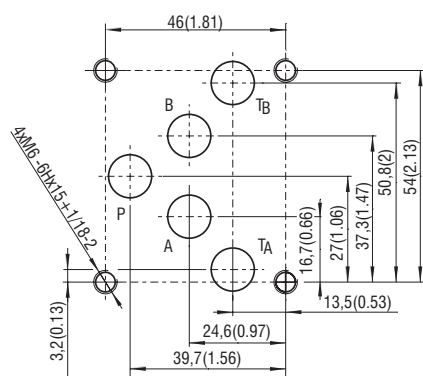
Technical Data
ISO 4401-05-04-0-05

 Ports P, A, B, T - max. $\varnothing 11.2$ mm (0.44 in)

Valve Size	10 (D05)	
Maximal flow at pressure 320 bar (4640 PSI)	l/min (GPM)	80 (21)
Max. operating pressure at ports P, A, B	bar (PSI)	350 (5080)
Maximum operating pressure at port T	bar (PSI)	210 (3050)
Fluid temperature range (NBR)	°C (°F)	-30 ... +80 (-22 ... +176)
Fluid temperature range (FPM)	°C (°F)	-20 ... +80 (-4 ... +176)
Ambient temperature max.	°C (°F)	-30 ... +50 (-22 ... +122)
Nominal flow rate Q_N at $\Delta p=10$ bar (145 PSI)	l/min (GPM)	30 (7.9) / 60 (15.9) / 80 (21.13)
Hysteresis	%	< 6
Mass	kg (lbs)	4.3 (9.48) 5.8 (12.78)
Protection degree (for version PRM*EK)		IP65
Technical Data of the Proportional Solenoid		
Nominal supply voltage	V	12 DC 24 DC
Limit current	A	1.9 1.1
Mean resistance value at 20 °C (68 °F)	Ω	4.7 13.9
Technical Data of the Electronics		
Supply voltage range	V DC	11.2...14.7 20...30
Stabilized voltage for control	V DC	5 (R > 1k Ω) 5 (R \geq 1k Ω)
Maximum output current	A	2.4 (R < 4 Ω) 1.5 (R < 10 Ω)
Ramp adjustment range	s	0.05...3
Dither frequency	Hz	90 / 60
Dither amplitude	%	0...30
	Data Sheet	Type
General information	GI_0060	Products and operating conditions
Coil types / Connectors	C_8007 / K_8008	C31* / K*
Mounting interface	SMT_0019	Size 10
Spare parts	SP_8010	
Subplates	SP_0002	DP*-10

Ordering Code

PRM6-10 [] / [] - [] [] [] [] - []

Proportional directional control valve

Valve size

Spool symbols

see table „Spool Symbols“

Nominal flow rate at $\Delta p = 10$ bar (145 PSI)

30 l/min (7.9 GPM)	30
60 l/min (15.85 GPM)	60
80 l/min (21 GPM)	80

Rated supply voltage of solenoids (at the coil terminal)

12 V DC	12
24 V DC	24

Electronics on board / Position at solenoid

connection by connector M12 x 1

(4-pin connector, supplied with counterpart)

on board electronics (solenoid „a“)

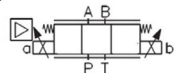

EK

on board electronics (solenoid „b“)*

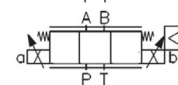

EKB

Surface treatment
 No designation standard
 A zinc-coated (ZnCr-3), ISO 9227 (240 h)
 B zinc-coated (ZnNi), ISO 9227 (520 h)

Seals
 No designation NBR
 V FPM (Viton)

Manual Override
 No designation standard
 N1 protected with retaining nut
 N2 protected with rubber boot

Connector
 only for version without on board electronic „EK“
 EN 175301-803-A
 E1 E1 with quenching diode
 E2 AMP Junior Timer - radial directions (2 pins; male)
 E3 E3 with quenching diode
 E4 loose conductors (two insulated wires)
 E8 E8 with quenching diode
 E9 deutsch DT04-2P - axial direction
 E12A E12A with quenching diode
 E13A

*For valve versions with one solenoid the designation „B“ with OBE is not shown.

- Valves without integrated control electronics with E1, E2 coils (with connector according to EN 175301-803, form A) are delivered in the standard version with connector sockets.
- For proportional valves with two solenoids, one solenoid must be de-energized before the other solenoid can be charged.
- Mounting bolts M6 x 40 DIN 912-10.9 or studs must be ordered separately. Tightening torque is 14 Nm (10.3 lbf.ft).
- Besides the shown, commonly used valve versions other special models are available.
- Contact our technical support for their identification, feasibility and operating limits.

Spool Symbols

Type	Symbol	Type	Symbol
2Z51		3Z11	
2Z11		3Z12	 $\frac{q_A}{q_B} = \frac{1}{2}^*$
2Y51		3Y11	
2Y11		3Y12	 $\frac{q_A}{q_B} = \frac{1}{2}^*$

*Model for cylinders with asymmetric piston area ratio 1:2

Characteristics measured at $v = 32 \text{ mm}^2/\text{s}$ (156 SUS)

Operating limits: Flow direction $P \rightarrow A / B \rightarrow T$ or $P \rightarrow B / A \rightarrow T$

Nominal flow 30 l/min (7.95 GPM)

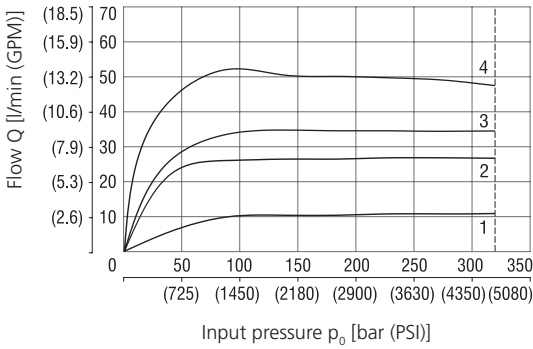

Nominal flow 60 l/min (15.85 GPM)

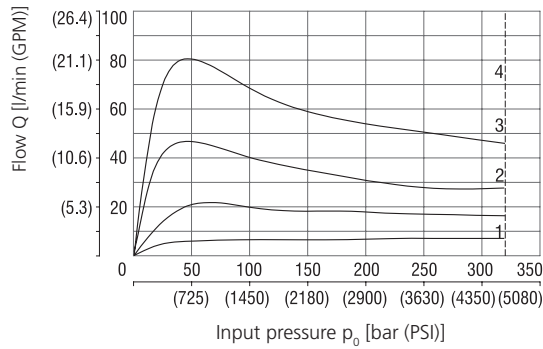

Nominal flow 80 l/min (21.13 GPM)

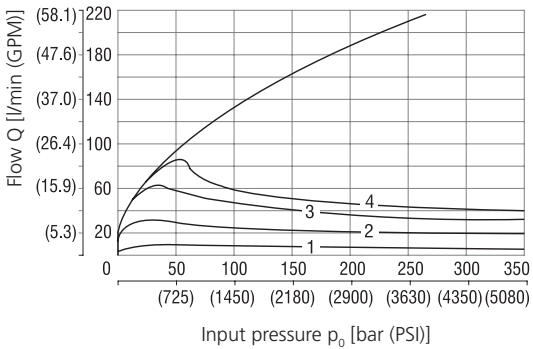

Solenoid current:

- 1 = 40 %
- 2 = 60 %
- 3 = 80 %
- 4 = 100 %

Regulated flow related to control signal $\Delta p = 10 \text{ bar}$ (145 PSI)

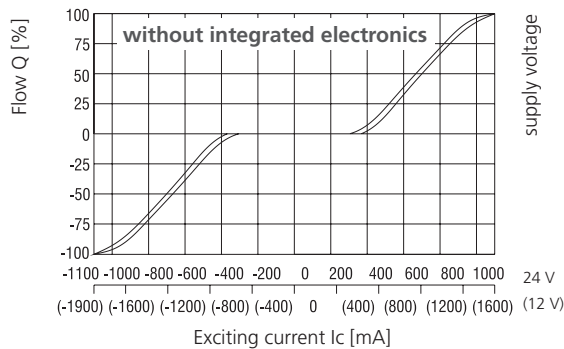
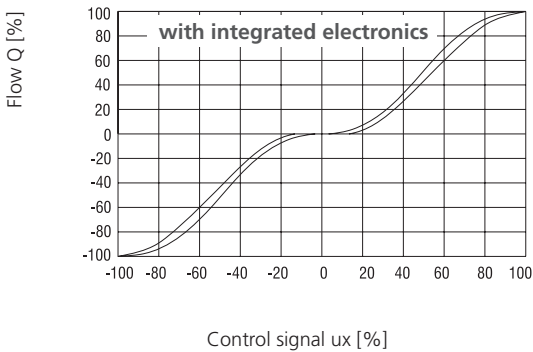

The coil current which initializes the flow through the proportional directional valve can differ due to the production tolerances about in a range of $\pm 6\%$ of the limit current.

Transient Characteristic measured at $v = 32 \text{ mm}^2/\text{s}$ (156 SUS), $\Delta p = 10 \text{ bar}$ (145 PSI)

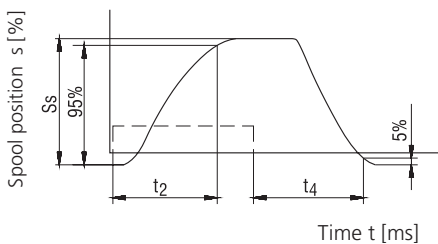

Steady Spool Position S_s [%]	t_2 [ms]	t_4 [ms]
100	85	100
75	70	85
50	55	75
25	45	55

The values in table have only an informative character. The times of the transient characteristics at pressure or flow control will be in a particular hydraulic circuit always longer.

---- the control signal course of the integrated electronics

Frequency Response

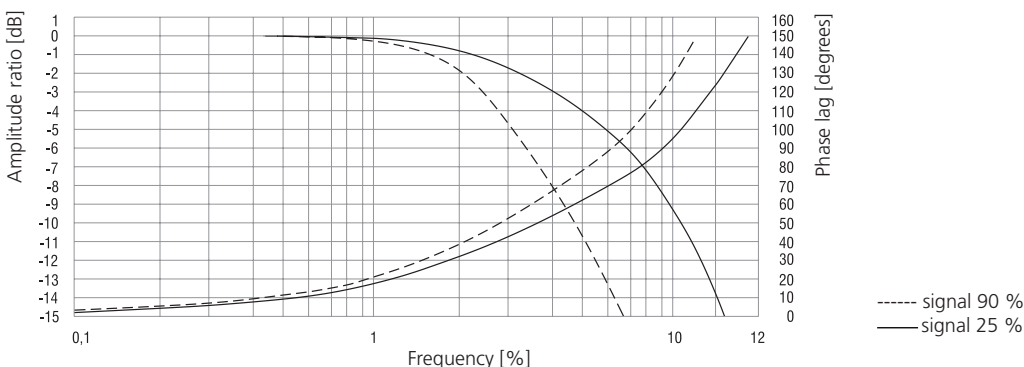

Component Arrangement on the Electronic Card

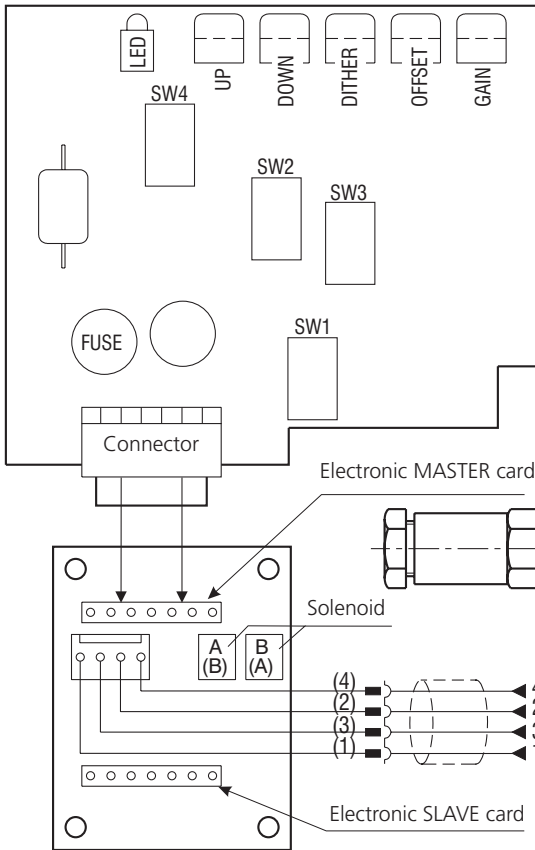

PIN	Description	Wire Colors	Connection Connector - Electronics
1	+24 V (Ucc) (+12 V)	(1)	brown
2	control	(2)	white
3	0 V	(3)	blue
4	+10 V (+5 V)	(4)	black

SW1 - control signal choice
 SW2 - control signal choice
 SW3 - control signal choice
 SW4 - dither frequency

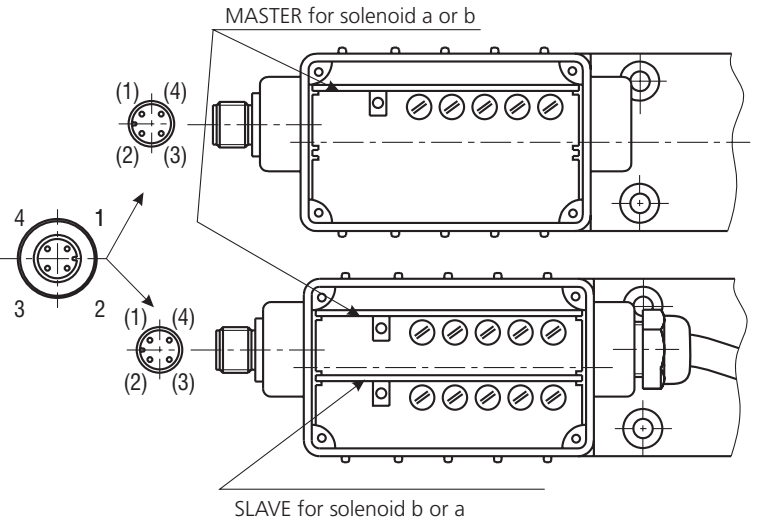

Attention: The control signal must have the same ground potential as the supply source.

Table of the Switch Configuration for the Control Signal Choices

		PRM2-062				PRM2-063	
		0 ... 5 V	0 ... 10 V (0...5 V)*	0 ... 20 mA	4 ... 20 mA	Ucc/2 ±10 V (±5 V)*	±10 V (±5 V)*
MASTER M	SW1						
	SW2						
	SW3						
	SW4	90 Hz			60 Hz		
SLAVE S	SW1						
	SW2						
	SW3						
	SW4					90 Hz	60 Hz

Designation of the basic manufacture setting.

The ramp functions are adjusted on their minimum values, the dither is set to the optimal value with respect to hysteresis. Offset and gain are adjusted according to the characteristic on page 3 and 4. The manufacturer does not recommend to change these adjusted values.

* Input signal level for the 12 V electronic unit.

Block Diagram

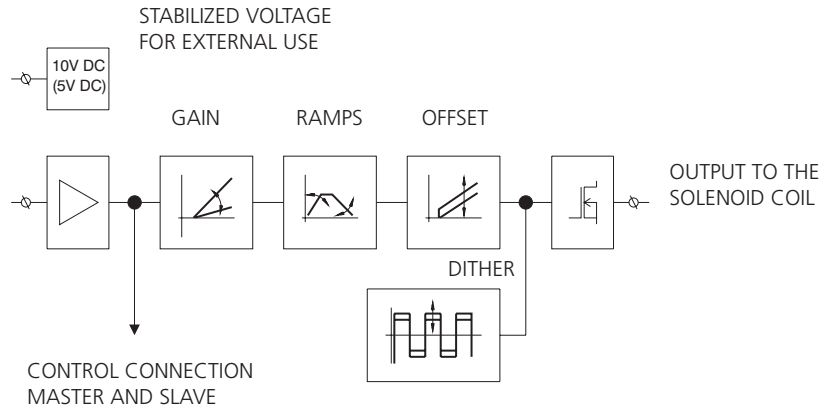

Setting of Control Electronics

Valve PRM2-102*EK (with one solenoid)

Control with external voltage source 0...10 V, 0 ... 5 V (factory setting) or with external potentiometer $R > 1 \text{ k}\Omega$

Master card for solenoid a (b)

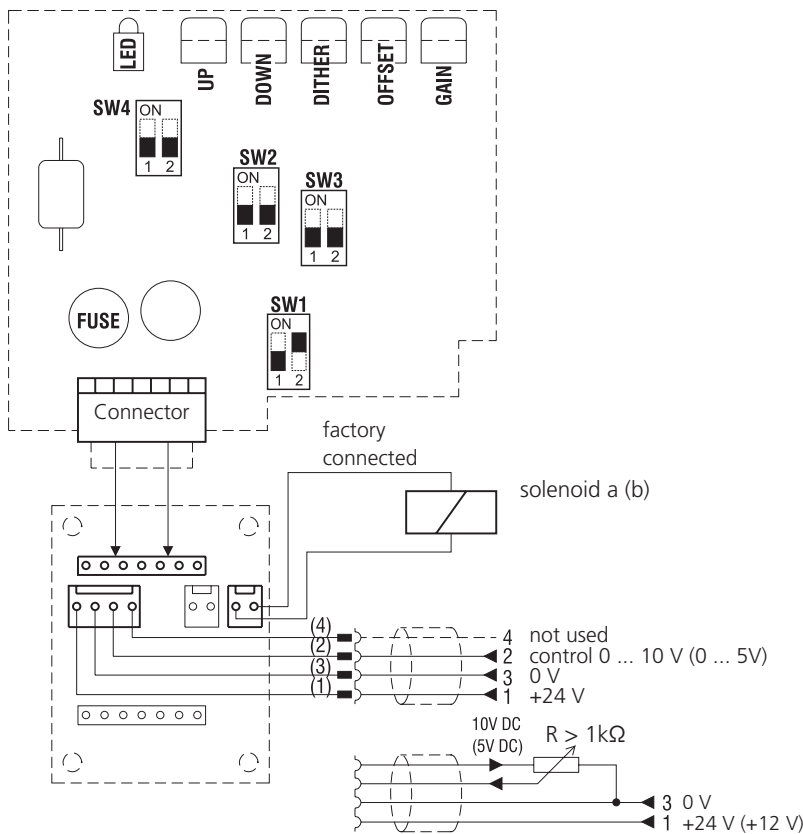

Factory set values:

- Control signal: 0 - 10 V (0 - 5 V)
- Dither: frequency 90 Hz
amplitude - optimum
- Ramps: 0.05 s
- Offset, gain: according to the characteristics on page 3



The control signal must have the same ground potential as the supply source.

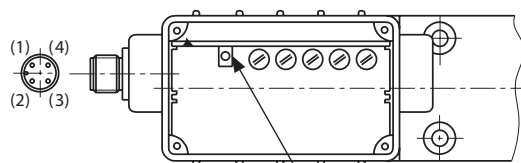
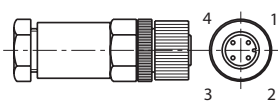

MASTER for solenoid a (b)

Wire colors

(connection connector - electronics)

- (1) - brown
- (2) - white
- (3) - blue
- (4) - black

Setting of Control Electronics

Valve PRM2-102*EK (with one solenoid)

Control with external source 0 ... 5 V, 0 ... 20 mA, 4 ... 20 mA

Master card for solenoid a (b)

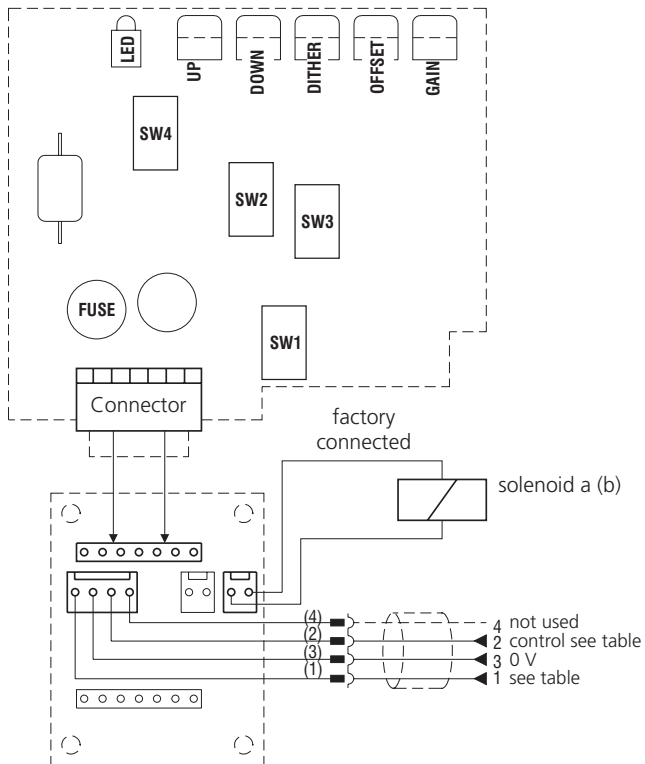

Control with external source			
	0 ...5 V	0 ...20 mA	4 ...20 mA
SW1			
SW2			
SW3			
SW4			
PIN 1 (1)	+24 V	+24 V (+12 V)	+24 V (+12 V)
PIN 2 (2)	0 ...5 V	0 ...20 mA	4 ...20 mA

Follow the subsequent steps to modify the factory settings:

1. Unscrew the electronics cover
2. Carefully remove the master card
3. Flip the switch SW1 (2 or 3) in position shown in the table
4. Put in the master card and fix the electronics cover
5. Connect the voltage +24 V (+12 V) from an external supply source to terminals 1 and 3 of the connector
6. Bring the control voltage (current) from an external source to terminals 2 and 3 of the connector

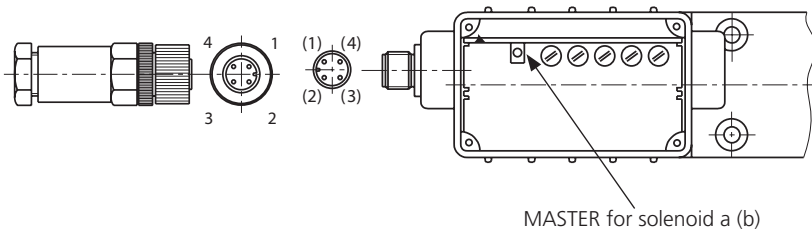

Wire colors (connection connector - electronics)

- (1) - brown
- (2) - white
- (3) - blue
- (4) - black



The control signal must have the same ground potential as the supply source.



Designation of the basic factory setting.
The ramp functions are adjusted on their minimum values.
The dither is set to the optimal value with respect to hysteresis.
Offset and gain are adjusted according to the characteristic on page 3.
The manufacturer does not recommend to change these adjusted values.

Setting of Control Electronics

Valve PRM2-103*EK (with two solenoids), factory setting, other control possibilities

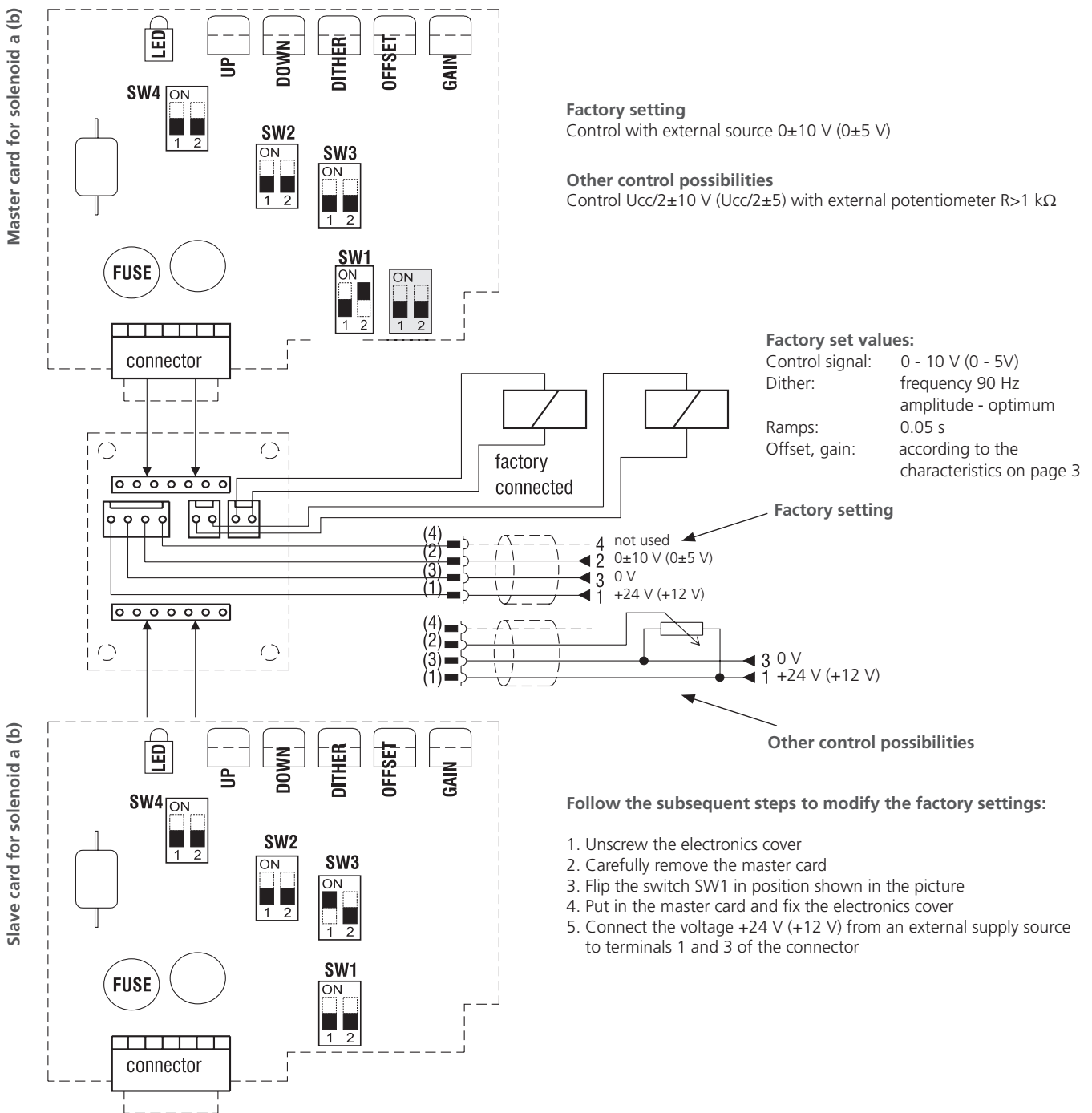

The control signal must have the same ground potential as the supply source.

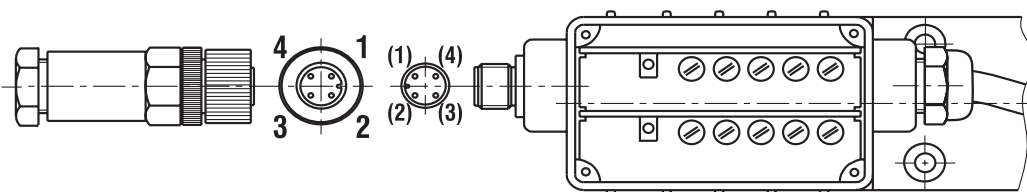

Ramp Adjustment (Up, Down)

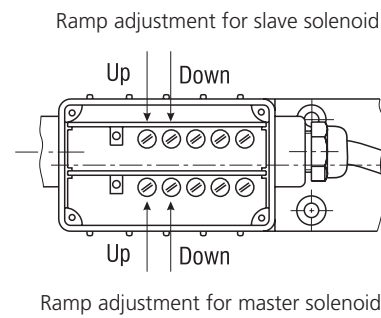
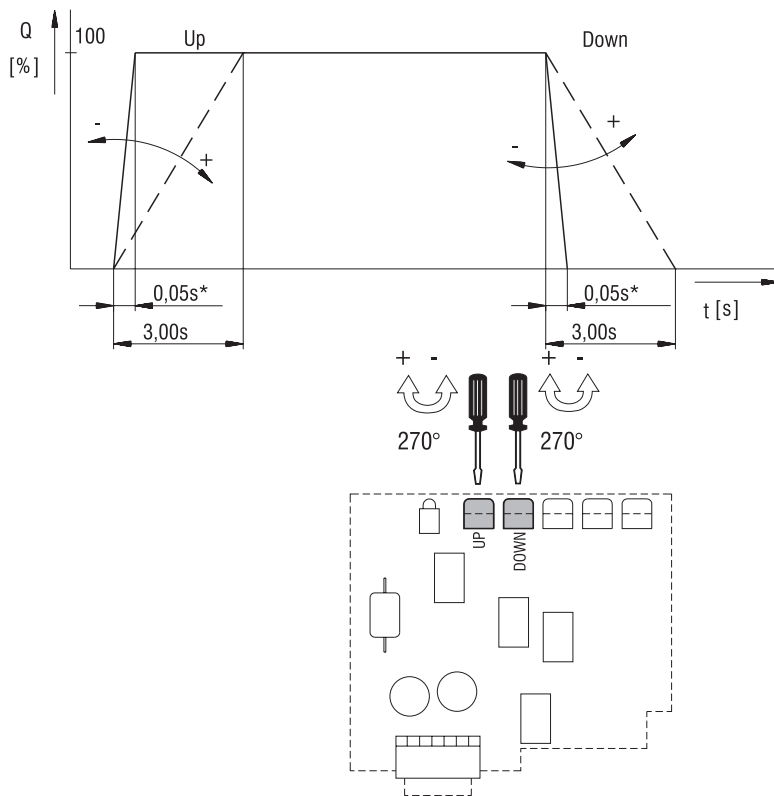

* The value has only an informative character with respect to the particular type of the proportional directional valve (see page 3).



The factory setting of the ramp is at the minimum value.

Dither Adjustment

Amplitude - potentiometer (dither) (0 - 30 %)

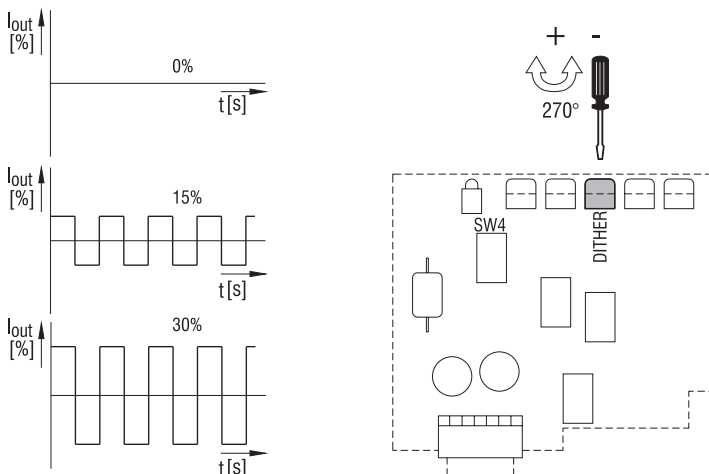

Frequency - switch SW4

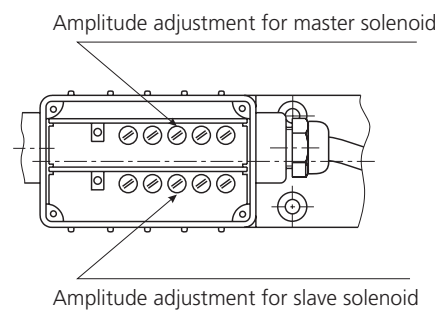

The dither is adjusted to minimize hysteresis.

Offset, Gain Parameters Adjustment

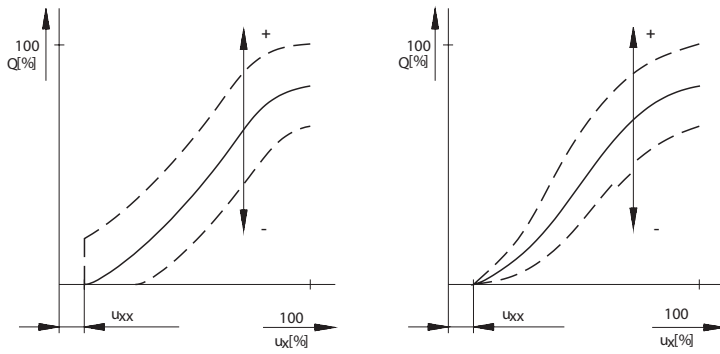

i The factory setting of the offset and gain parameters is specific for the solenoids used. The manufacturer does not recommend to change these settings.

Nominal Electronics Supply Voltage (V)	Area Insensitive to Control Signal u_{xx} (%)
12	1 ... 3
24	0.5 ... 2

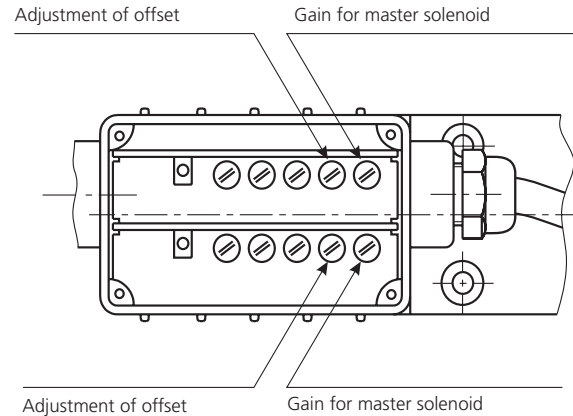
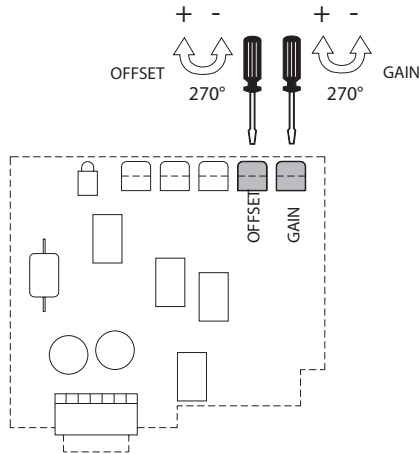

Solenoid Coil in millimeters (inches)

E1, E2 Protection Degree IP65	E3A, E4A Protection Degree IP67	E8, E9 Protection Degree IP65	E12A, E13A Protection Degree IP67 / 69K
		 Note: A = Standard 300 mm, (11.8 in) other lengths on demand	

The indicated IP protection level is only achieved if the connector is properly mounted.

Manual Override in millimeters (inches)

No Designation - Standard	Designation N1 - Cap Nut Covered	Designation N2 - Rubber Boot Protected

In case of solenoid malfunction or power failure, the spool of the valve can be shifted by manual override as long as the pressure in port T does not exceed 25 bar (363 PSI). For alternative manual overrides contact our technical support.

Dimensions in millimeters (inches)

PRM6-103x/x-xxx-x

Functional symbols:
3Z11, 3Z12, 3Y11, 3Y12

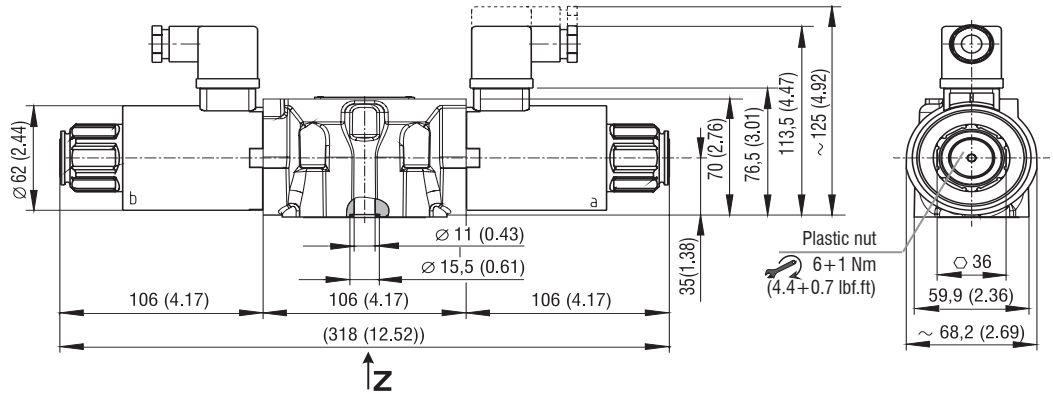
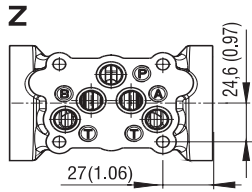

PRM6-102x/x-xxx-x

Functional symbols:
2Z11, 2Y11

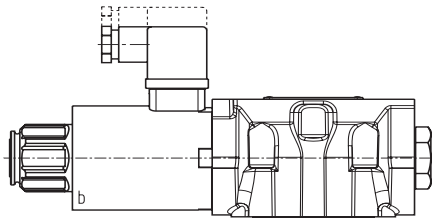

Functional symbols:
2Z51, 2Y51

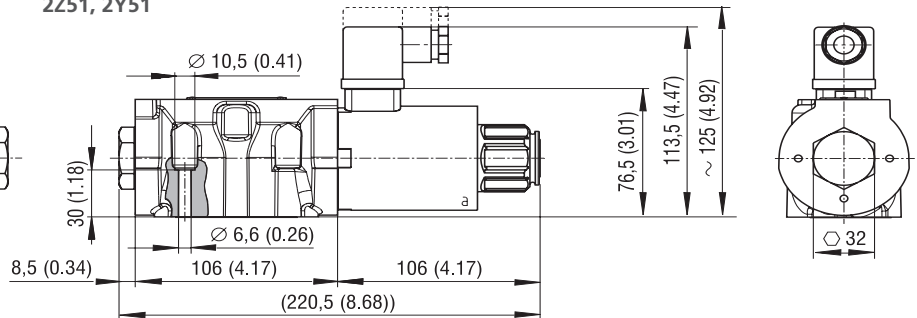

PRM6-103x/x-xxEKx-x

Functional symbols:
3Z11, 3Z12, 3Y11, 3Y12

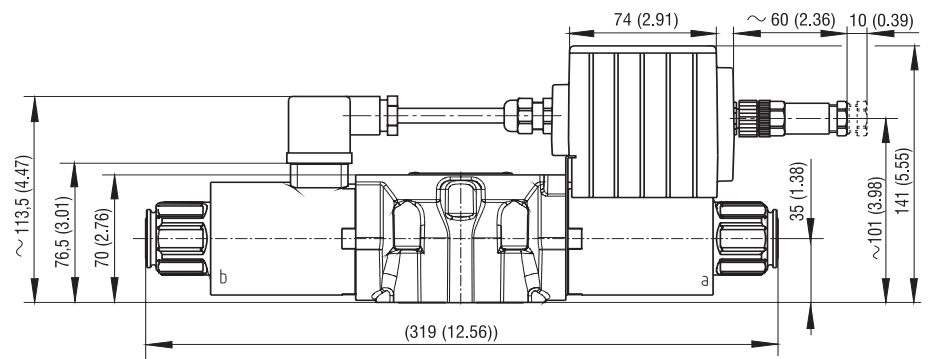
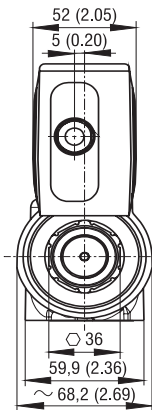

PRM6-103xB/x-xxEKx-x

Functional symbols:
3Z11B, 3Z12B, 3Y11B, 3Y12B

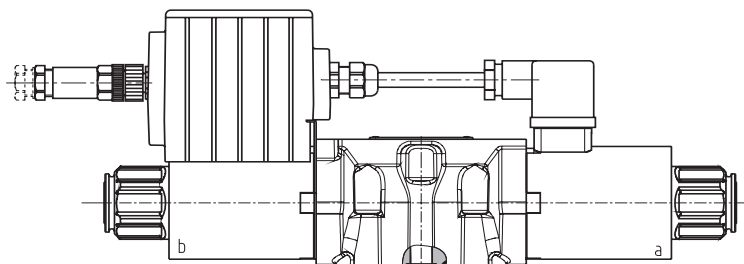

PRM6-102x/x-xxEKx-x

Functional symbols:
2Z11, 2Y11

Functional symbols: 2Z51, 2Y51

