

Data sheet

Temperature Sensors

CANopen & SAE J1939



The DST T92C OEM temperature transmitter is designed for use in harsh environments as Mobile hydraulic applications.

Danfoss DST T92C is designed to comply with CANopen as well as SAE J1939. It is a cost effective way to control complex machines and make also replacements cost- efficient while offering additional benefits such as diagnostic and communication. The DST T92C is with E1 type approval (vehicles and vehicle parts according to European directives for use on public roads).

The DST T92C is offered with a measuring range of -40 – 150 °C.

Features

- Designed for use in off-highway vehicles
- For ambient temperature up to 125 °C
- Measuring range -40 – 150 °C
- CANopen
- SAE J1939
- Wetted parts made of stainless steel
- Fully welded design and therefore no use of gasket in combination with wetted parts

Approvals

- CE marked
- E1 type approval

Note: In respect to Customer Change Notification, only changes in relation to Form Fit and Function can be informed upon!

Data sheet | Temperature Transmitter DST T92C

Technical data

General data

Measuring range	-40 – 150 °C
Overall accuracy	0.6% FS [-40 – 125° C]
	0.4% FS [-40 – 85° C]

Response times

Type	Indicative response times			
	Water 0.2 m/s		Air 2 m/s	
	$t_{0.5}$	$t_{0.9}$	$t_{0.5}$	$t_{0.9}$
DST T92C reaction time (guidance values)	4 s.	9.6 s.	45 s.	160 s.

Environmental and mechanical data

Media temperature range	-40 – 150 °C	
Ambient temperature range	-40 – 125 °C	
Storage temperature range	-40 – 125 °C	
Voltage supply	9 – 36 V	
Electrical Protection	Short circuit reverse polarity protection	
EMC	EN 61326-1	
Vibration stability	20 g	EN 60068-2-6
	Random	ISO16750-3
Shock mechanical	50 g /11 ms, 30 g/6ms, 300 g	EN60068-27
Enclosure	1.4301/PBT-GF30	
Material with media contact	1.4571, 1.4542/P1070, FKM	
Weight	75 g	
Enclosure	IP67	
CAN	Bitrate	CANopen: 125 kbit/s, configurable SAE J1939:250 kbit/s
	Digital filter	averaging filter, configurable for CANopen
	Output protocol	Danfoss-CAN, CANopen, SAE J1939
	Electrical connection	M12 connector, DIN Bayonet (DIN 72585), DT04-4 p

Ordering standard

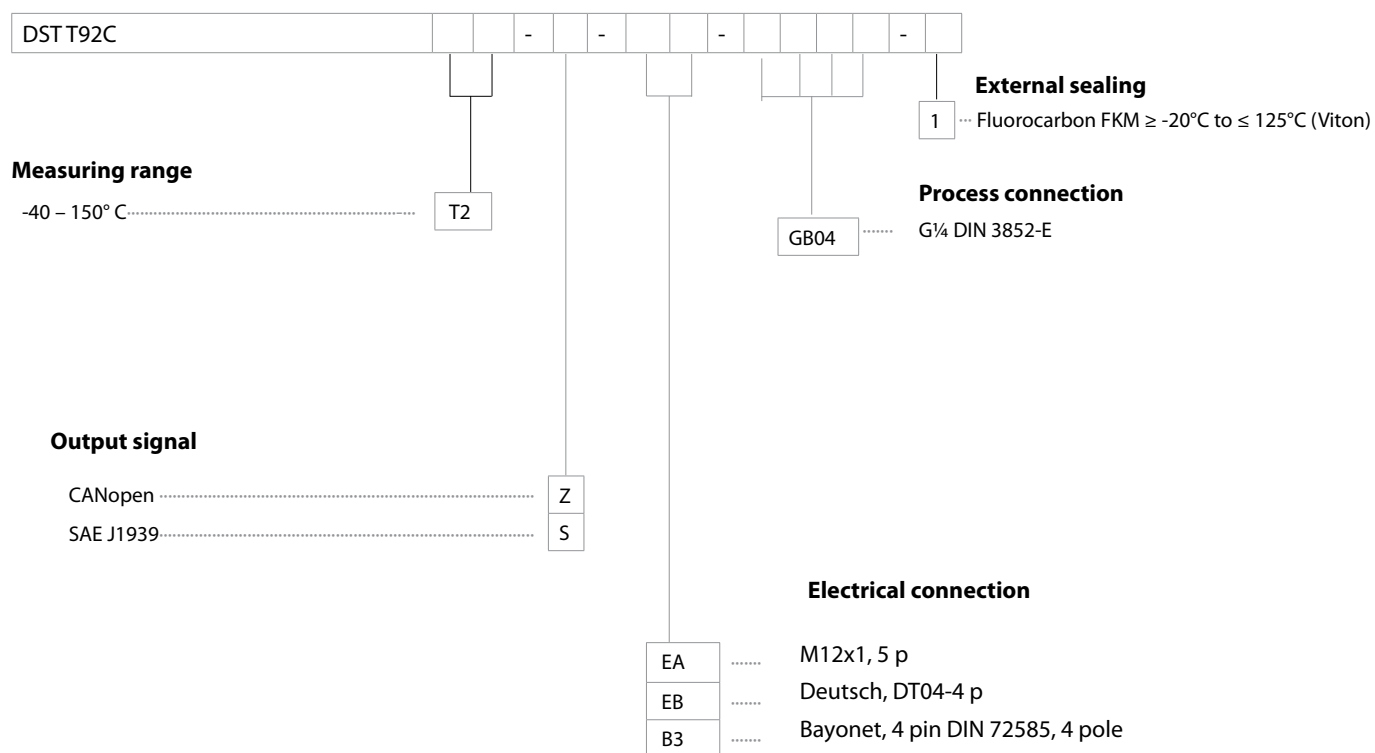

Data sheet | Temperature Transmitter DST T92C

Dimensions / Combinations

Type code	EA	B3	EB
	M12x1, 5-pol	Bayonet, DIN 72585, 4pole	Deutsch, DT04-4 p

HEX 22	
Type	G 1/4, DIN 3852-E
Gasket	16.5 x 11.6 x 1.5 FKM
Type code	GB04
Recommended torque	< 35 Nm

Electrical connections

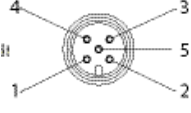
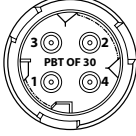
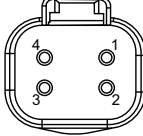
Type code	EA	B3	EB
	 <p>M12x1, 5-pole</p>	 <p>Bayonet DIN 72585, 4-pole</p>	 <p>Deutsch DT04-4 p</p>
Pin-plating	Tin plating on Nickel	Tin plating on Nickel	Tin plating on Nickel
CAN	Pin 1: PE, Housing Pin 2: VCC Pin 3: GND Pin 4: CAN_H Pin 5: CAN_L	Pin 1: VVC Pin 2: GND Pin 3: CAN_H Pin 4: CAN_L	Pin 1: CAN_L Pin 2: VCC Pin 3: GND Pin 4: CAN_H

Recommended terminal layout

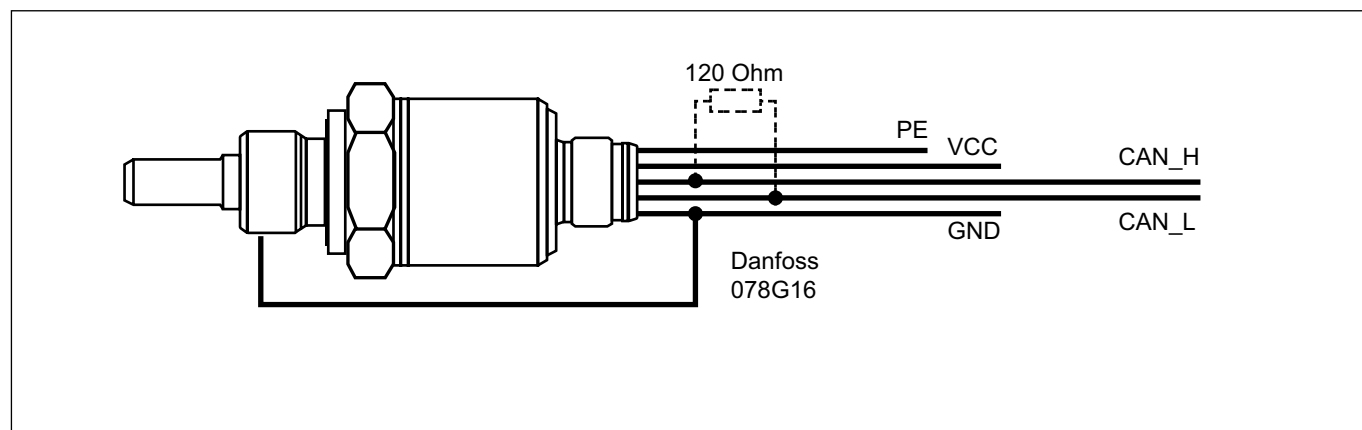

ENGINEERING
TOMORROW

The Danfoss logo is a stylized, cursive script of the word "Danfoss" in white, set against a red rectangular background.